

# Technical Guide: Structure-Activity Relationship (SAR) of Pyridinyl-Oxadiazoles

**Author:** BenchChem Technical Support Team. **Date:** May 2026

## Compound of Interest

**Compound Name:** 5-Pyridin-3-yl-1,2,4-oxadiazole-3-carboxylic acid

**CAS No.:** 1086380-42-8

**Cat. No.:** B1452594

[Get Quote](#)

## Executive Summary

The pyridinyl-oxadiazole scaffold represents a privileged structure in modern medicinal chemistry, bridging the gap between lipophilic efficiency and metabolic stability. By coupling the electron-deficient pyridine ring with the rigid, non-basic oxadiazole linker, researchers can access a chemical space that mimics amide/ester bioisosteres while significantly improving proteolytic resistance. This guide dissects the structure-activity relationships (SAR) of this hybrid class, focusing on its application in oncology (STAT3/VEGFR inhibition) and infectious diseases (MRSA/TB).

## Part 1: Chemical Architecture & Pharmacophore

The efficacy of pyridinyl-oxadiazoles relies on a tripartite architecture: the Pyridine Head, the Oxadiazole Linker, and the Distal Tail.

### The Pyridine "Head" (Warhead)

- Role: Acts as a hydrogen bond acceptor (HBA) and modulates the electronic surface potential.
- Positional Isomerism:
  - 2-Pyridyl: Often facilitates chelation with metal centers in metalloenzymes or specific H-bonding in pockets like Kinases.
  - 3-Pyridyl / 4-Pyridyl: Generally favored for intercalating into hydrophobic pockets where the nitrogen atom requires specific orientation away from steric bulk.
- Substitutions: Electron-withdrawing groups (EWGs) like  
or halogens on the pyridine ring often enhance metabolic stability by reducing oxidative metabolism at the ring carbons.

## The Oxadiazole "Linker"[1]

- Bioisosterism: A stable replacement for amide ( ) or ester ( ) linkages.
- Isomers:
  - 1,3,4-Oxadiazole: Symmetric, often exhibits higher thermal stability and better metabolic resistance.
  - 1,2,4-Oxadiazole: Asymmetric; the dipole moment is distinct, often leading to different solubility profiles and binding modes.

## The Distal "Tail"

- Role: Provides the necessary lipophilicity (LogP) to cross cell membranes and engage in hydrophobic interactions ( $\pi$ - $\pi$  stacking) with target proteins.
- Optimization: Introduction of bulky lipophilic groups (e.g., naphthyl, 4-chlorophenyl) typically increases potency but must be balanced against aqueous solubility.

## Visualization: Pharmacophore Logic

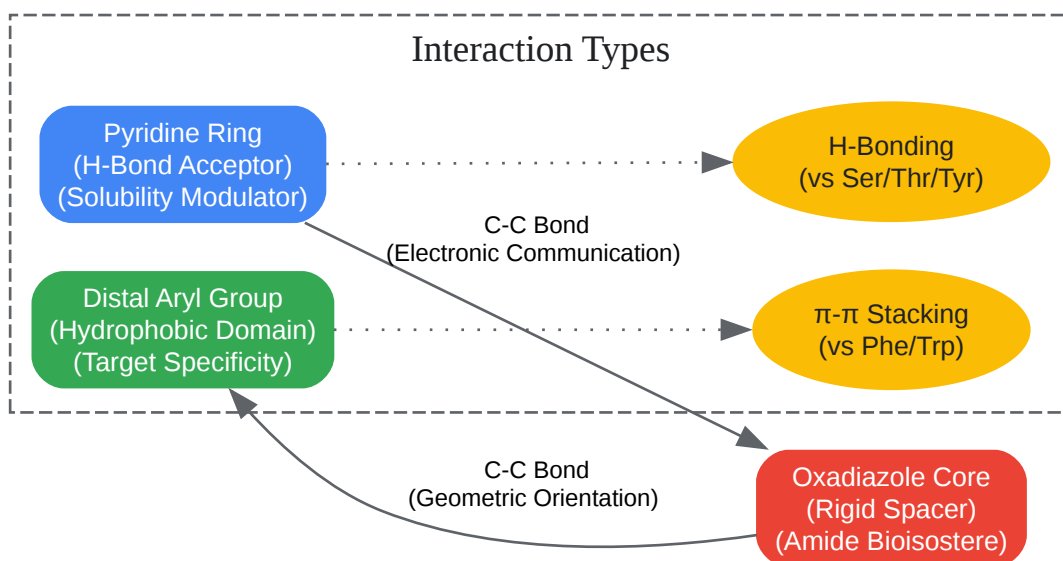

[Click to download full resolution via product page](#)

Figure 1: Pharmacophore connectivity map illustrating the functional roles of the tripartite scaffold.

## Part 2: SAR Deep Dive

### Pyridine Substitution Effects

The electronic nature of the pyridine ring is a critical tunable parameter.

Substituent (R)	Electronic Effect	Impact on Activity (General)	Mechanism
-H	Neutral	Baseline	Standard binding affinity.
-OMe / -NH <sub>2</sub>	Electron Donating (EDG)	Increased (Antiproliferative)	Increases electron density on Pyridine N, enhancing H-bond acceptor strength.
-Cl / -Br	Weak EWG + Lipophilic	Variable	Halogens improve membrane permeability but may reduce solubility.
-CF <sub>3</sub>	Strong EWG	High (Antibacterial)	Enhances metabolic stability; prevents oxidative degradation of the ring.

## The Oxadiazole Isomer Debate

- 1,3,4-Oxadiazole: Frequently cited in anticancer literature (e.g., STAT3 inhibitors). The symmetry allows for a linear alignment of substituents, often fitting into narrow enzyme channels.
- 1,2,4-Oxadiazole: Prominent in antimicrobial agents (e.g., anti-TB).<sup>[1]</sup> The asymmetry allows for "L-shaped" conformations that may fit globular binding pockets better.

## Optimization Logic Tree

When optimizing a hit compound, follow this logic flow to improve potency and drug-likeness.

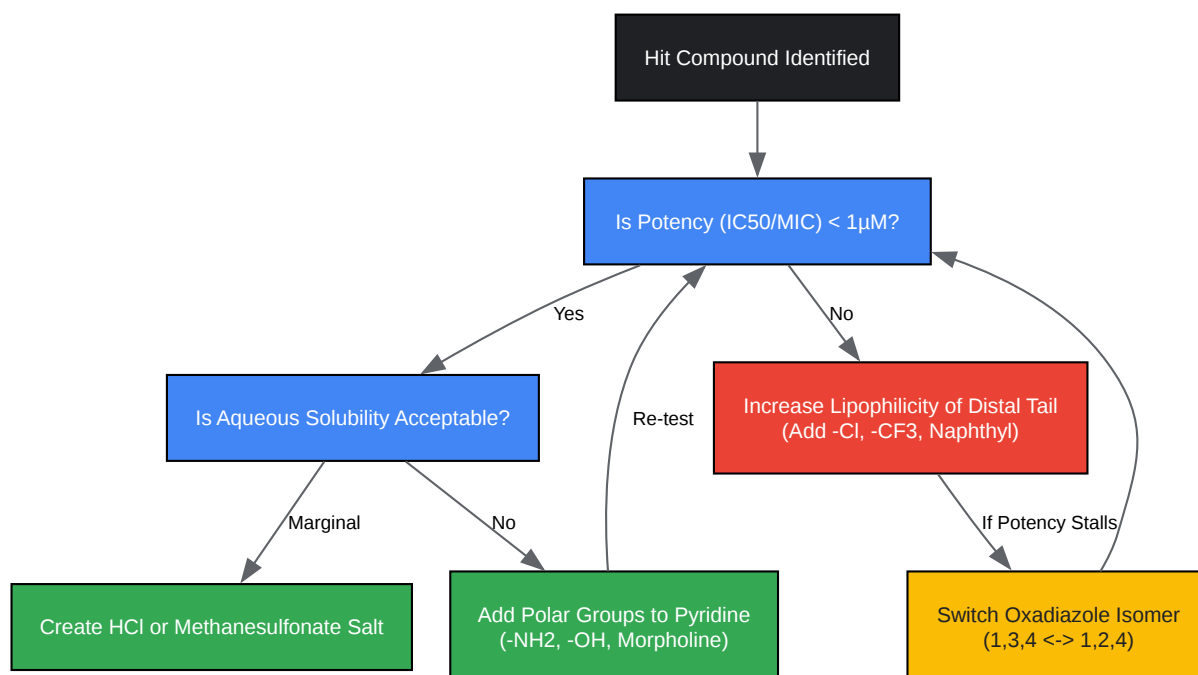

[Click to download full resolution via product page](#)

Figure 2: SAR optimization decision tree for refining pyridinyl-oxadiazole hits.

## Part 3: Validated Experimental Protocols

To ensure reproducibility and trustworthiness, the following protocols are standardized based on high-yield literature methods.

### Protocol A: Synthesis of 2,5-Disubstituted 1,3,4-Oxadiazoles

Method: Phosphorus Oxychloride (

) Mediated Cyclization.<sup>[2][3]</sup> Rationale: This method is preferred over sulfuric acid cyclization due to higher yields and cleaner workup for pyridine-containing substrates.

- Reagents: Pyridine-carboxylic acid hydrazide (1.0 eq), Aromatic Carboxylic Acid (1.0 eq),

(excess, solvent/reagent).

- Procedure:
  - Mix the hydrazide and carboxylic acid in a round-bottom flask.
  - Add  
  
(typically 5–10 mL per mmol of substrate).
  - Reflux at 100–110°C for 6–8 hours. Monitor via TLC (Mobile phase: Hexane/Ethyl Acetate).
  - Quenching (Critical): Cool the mixture to RT. Pour slowly onto crushed ice with vigorous stirring (Exothermic!).
  - Neutralization: Adjust pH to ~7–8 using solid  
  
or 20% solution.
  - Isolation: Filter the precipitate, wash with cold water, and recrystallize from Ethanol/Methanol.

## Protocol B: Biological Evaluation (MTT Cytotoxicity Assay)

Target: Cancer cell lines (e.g., MCF-7, A549). Rationale: Colorimetric assay measuring mitochondrial dehydrogenase activity as a proxy for cell viability.

- Seeding: Seed cells in 96-well plates (   
  
 cells/well) in RPMI-1640 or DMEM media. Incubate for 24h at 37°C (   
  
 ).
- Treatment: Add test compounds dissolved in DMSO (Final DMSO concentration   
  
 ). Include Positive Control (e.g., Doxorubicin) and Vehicle Control.
- Incubation: Incubate for 48h or 72h.

- MTT Addition: Add of MTT solution ( in PBS) to each well. Incubate for 3–4 hours until purple formazan crystals form.
- Solubilization: Carefully remove media. Add DMSO to dissolve crystals. Shake plate for 15 mins.
- Measurement: Read Absorbance at 570 nm (reference 630 nm). Calculate using non-linear regression.

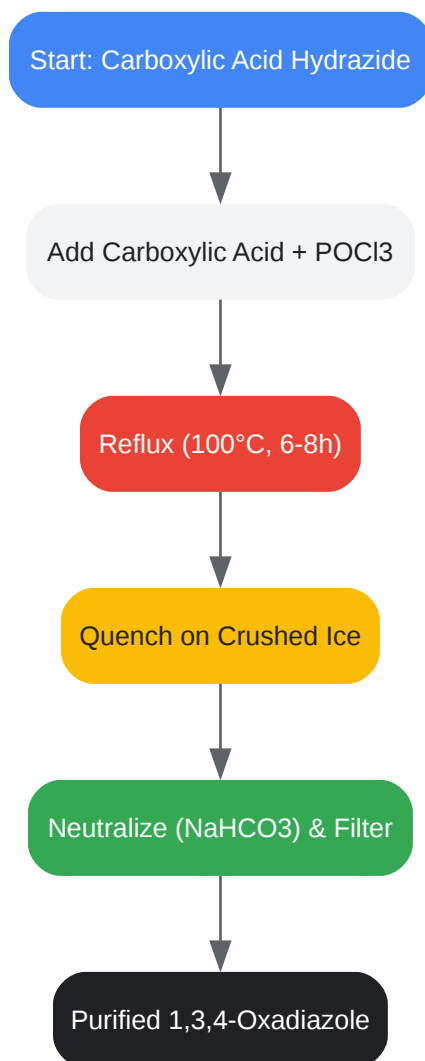

[Click to download full resolution via product page](#)

Figure 3: Step-by-step workflow for the POCl<sub>3</sub>-mediated synthesis of 1,3,4-oxadiazoles.

## Part 4: Case Studies & Applications

### Case Study 1: Anticancer (STAT3 Inhibition)

- Target: Signal Transducer and Activator of Transcription 3 (STAT3).
- Mechanism: Pyridinyl-oxadiazoles mimic the peptide backbone, disrupting the SH2 domain dimerization.
- Key Finding: Substitution at the 2-position of the oxadiazole with a 4-pyridyl group showed superior inhibition compared to phenyl analogs, likely due to specific H-bonding with the STAT3 pocket residues [1].

### Case Study 2: Antimicrobial (MRSA)[5]

- Target: Penicillin-Binding Protein 2a (PBP2a).
- Compound Profile: 1,2,4-oxadiazoles with a 3-(4-trifluoromethyl)phenyl group and a 5-pyridyl group.
- Outcome: These compounds restore susceptibility to -lactams in resistant strains by allosterically modifying the PBP2a active site [2].

## References

- 1,3,4-Oxadiazole as a Potential Anti-Cancer Scaffold: A Review. *Biointerface Research in Applied Chemistry*, 2021. [\[Link\]](#)
- Structure–Activity Relationship for the Oxadiazole Class of Antibiotics. *Journal of the American Chemical Society / PMC*, 2014. [\[Link\]](#)
- Synthesis of Novel 2,5-disubstituted 1,3,4-Oxadiazole Derivatives. *PubMed*, 2020. [\[3\]](#)[\[4\]](#)[\[5\]](#) [\[Link\]](#)
- MTT Assay Protocol. *Springer Nature Experiments*. [\[Link\]](#)

- Synthesis and Biological Activity of 1,2,4-Oxadiazole Derivatives. *Journal of Medicinal Chemistry*, 2020. [[Link](#)]

### Need Custom Synthesis?

BenchChem offers custom synthesis for rare earth carbides and specific isotopic labeling.

Email: [info@benchchem.com](mailto:info@benchchem.com) or [Request Quote Online](#).

## Sources

- [1. tandfonline.com](https://www.tandfonline.com) [[tandfonline.com](https://www.tandfonline.com)]
- [2. researchgate.net](https://www.researchgate.net) [[researchgate.net](https://www.researchgate.net)]
- [3. Synthesis of novel of 2, 5-disubstituted 1, 3, 4- oxadiazole derivatives and their in vitro anti-inflammatory, anti-oxidant evaluation, and molecular docking study - PubMed](#) [[pubmed.ncbi.nlm.nih.gov](https://pubmed.ncbi.nlm.nih.gov)]
- [4. mdpi.com](https://www.mdpi.com) [[mdpi.com](https://www.mdpi.com)]
- [5. Synthesis of a series of novel 2,5-disubstituted-1,3,4-oxadiazole derivatives as potential antioxidant and antibacterial agents - PMC](#) [[pmc.ncbi.nlm.nih.gov](https://pubmed.ncbi.nlm.nih.gov)]
- To cite this document: BenchChem. [Technical Guide: Structure-Activity Relationship (SAR) of Pyridinyl-Oxadiazoles]. BenchChem, [2026]. [Online PDF]. Available at: [<https://www.benchchem.com/product/b1452594/docs#technical-guide-structure-activity-relationship-sar-of-pyridinyl-oxadiazoles>]

---

### Disclaimer & Data Validity:

The information provided in this document is for Research Use Only (RUO) and is strictly not intended for diagnostic or therapeutic procedures. While BenchChem strives to provide accurate protocols, we make no warranties, express or implied, regarding the fitness of this product for every specific experimental setup.

**Technical Support:** The protocols provided are for reference purposes. Unsure if this reagent suits your experiment?

**Need Industrial/Bulk Grade?** [Request Custom Synthesis Quote](#)

# BenchChem

Our mission is to be the trusted global source of essential and advanced chemicals, empowering scientists and researchers to drive progress in science and industry.

## Contact

Address: 3281 E Guasti Rd

Ontario, CA 91761, United States

Phone: (601) 213-4426

Email: [info@benchchem.com](mailto:info@benchchem.com)

[Contact our Ph.D. Support Team for a compatibility check](#)