

Stille Coupling Protocols for Pyrazine-Based Heterocycles: An In-Depth Technical Guide

Author: BenchChem Technical Support Team. **Date:** May 2026

Compound of Interest

Compound Name: *Methyl 3,5-dibromopyrazine-2-carboxylate*

CAS No.: *1035818-91-7*

Cat. No.: *B1451990*

[Get Quote](#)

Introduction: The Strategic Importance of Pyrazine Scaffolds and the Power of Stille Coupling

Pyrazine-based heterocycles are privileged scaffolds in medicinal chemistry and materials science, forming the core of numerous FDA-approved drugs and advanced organic materials. [1] Their unique electronic properties, arising from the two nitrogen atoms in the aromatic ring, impart desirable pharmacokinetic and pharmacodynamic characteristics. [2] The precise functionalization of the pyrazine core is therefore a critical endeavor for researchers aiming to modulate biological activity and material properties.

Among the arsenal of cross-coupling reactions, the palladium-catalyzed Stille coupling has emerged as a particularly robust and versatile method for forging carbon-carbon bonds on the pyrazine ring. [3][4][5] Developed by the late John Kenneth Stille, this reaction offers exceptional functional group tolerance and utilizes organotin reagents that are notably stable to air and moisture, often obviating the need for stringent anaerobic conditions or protecting group strategies. [3][6] This technical guide provides a comprehensive overview of Stille coupling protocols for pyrazine-based heterocycles, offering field-proven insights, detailed experimental

procedures, and troubleshooting guidance for researchers, scientists, and drug development professionals.

Core Principles and Mechanistic Insights

The Stille coupling reaction involves the palladium-catalyzed cross-coupling of an organostannane (R^1-SnR_3) with an organic halide or triflate (R^2-X). The catalytic cycle, as illustrated below, proceeds through a sequence of oxidative addition, transmetalation, and reductive elimination.

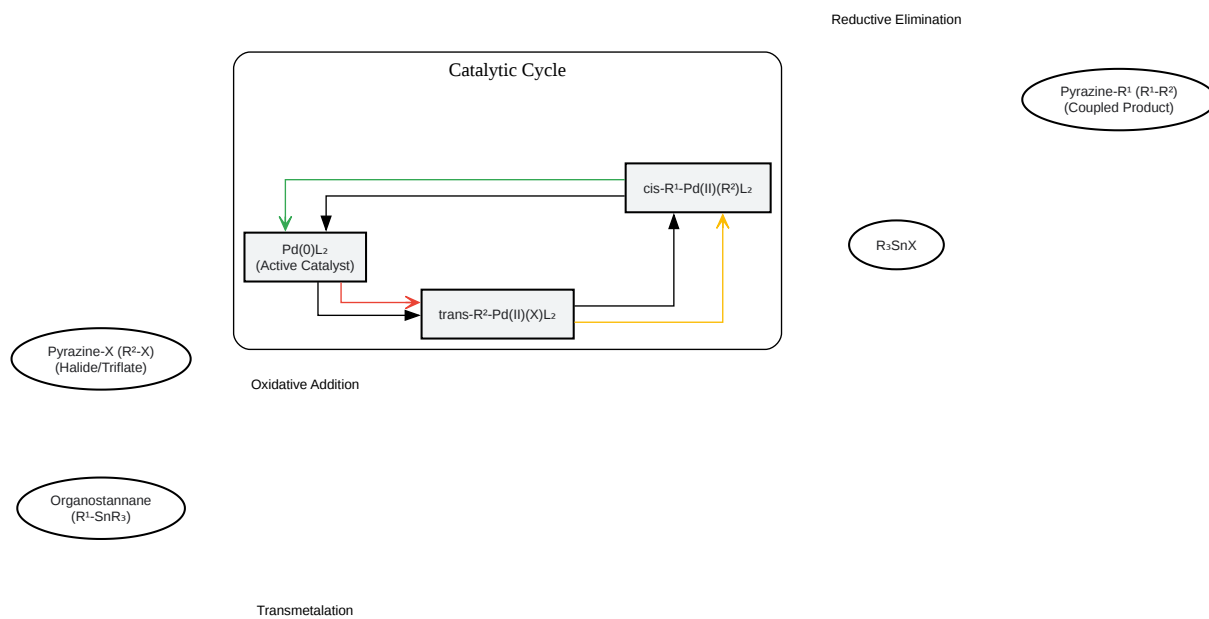

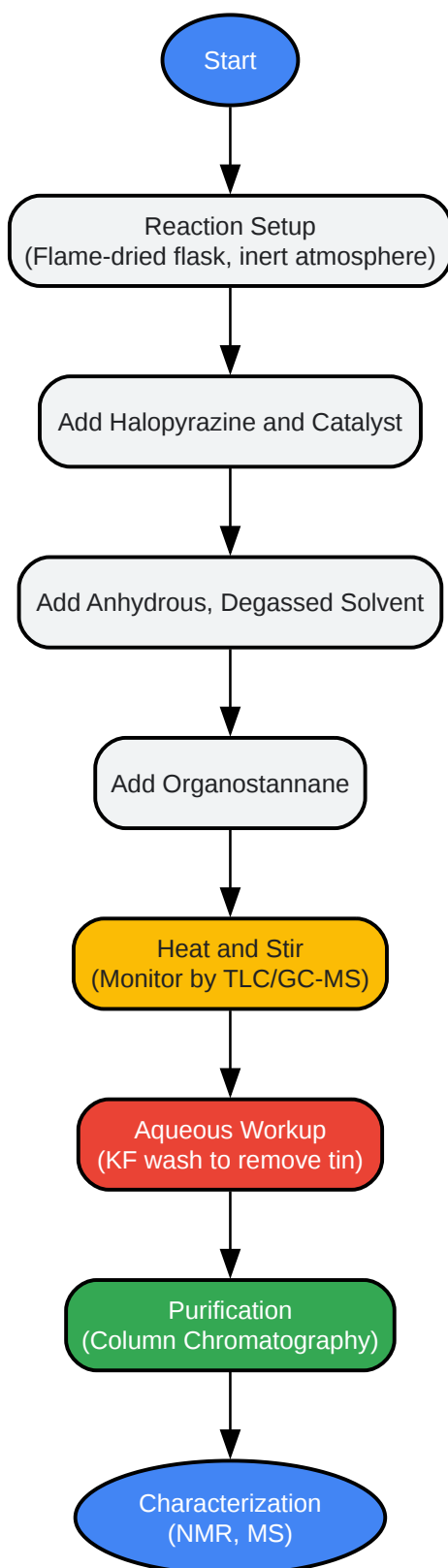

[Click to download full resolution via product page](#)

Need Custom Synthesis?

BenchChem offers custom synthesis for rare earth carbides and specific isotopic labeling.

Email: info@benchchem.com or [Request Quote Online](#).

Sources

- [1. pdf.benchchem.com](https://pdf.benchchem.com) [pdf.benchchem.com]
- [2. Facile Synthesis of 5-Aryl-N-\(pyrazin-2-yl\)thiophene-2-carboxamides via Suzuki Cross-Coupling Reactions, Their Electronic and Nonlinear Optical Properties through DFT Calculations](#) [mdpi.com]
- [3. Stille reaction - Wikipedia](#) [en.wikipedia.org]
- [4. Stille Coupling](#) [organic-chemistry.org]
- [5. chem.libretexts.org](https://chem.libretexts.org) [chem.libretexts.org]
- [6. Organic Syntheses Procedure](https://orgsyn.org) [orgsyn.org]
- To cite this document: BenchChem. [Stille Coupling Protocols for Pyrazine-Based Heterocycles: An In-Depth Technical Guide]. BenchChem, [2026]. [Online PDF]. Available at: [<https://www.benchchem.com/product/b1451990/docs#stille-coupling-protocols-for-pyrazine-based-heterocycles-an-in-depth-technical-guide>]

Disclaimer & Data Validity:

The information provided in this document is for Research Use Only (RUO) and is strictly not intended for diagnostic or therapeutic procedures. While BenchChem strives to provide accurate protocols, we make no warranties, express or implied, regarding the fitness of this product for every specific experimental setup.

Technical Support: The protocols provided are for reference purposes. Unsure if this reagent suits your experiment?

Need Industrial/Bulk Grade? [Request Custom Synthesis Quote](#)

BenchChem

Our mission is to be the trusted global source of essential and advanced chemicals, empowering scientists and researchers to drive progress in science and industry.

Contact

Address: 3281 E Guasti Rd

Ontario, CA 91761, United States

Phone: (601) 213-4426

Email: info@benchchem.com

[Contact our Ph.D. Support Team for a compatibility check](#)