

Introduction to Boc protection of primary amines

Author: BenchChem Technical Support Team. **Date:** May 2026

Compound of Interest

Compound Name: *tert-Butyl 2-bromo-3,4-difluorobenzylcarbamate*

CAS No.: 2231675-56-0

Cat. No.: B1451272

[Get Quote](#)

An In-Depth Technical Guide to the Boc Protection of Primary Amines

Authored by a Senior Application Scientist

Introduction: The Imperative of Amine Protection in Complex Synthesis

In the intricate world of organic synthesis, particularly within pharmaceutical and materials science, the amine functional group is a cornerstone of molecular architecture. Its inherent nucleophilicity and basicity are pivotal for forming carbon-nitrogen bonds, yet these same properties can be a liability, leading to undesired side reactions during multi-step syntheses. The strategic use of "protecting groups" is the chemist's answer to this challenge. A protecting group temporarily masks the reactive nature of a functional group, rendering it inert to specific reaction conditions, only to be removed later to reveal the original functionality.

Among the arsenal of amine-protecting groups, the tert-butyloxycarbonyl (Boc) group stands out as arguably the most ubiquitous and versatile tool in non-peptide chemistry.^[1] Its

widespread adoption is a testament to its robust stability across a wide range of nucleophilic and basic conditions, combined with its clean and efficient removal under mild acidic conditions.[2] This guide provides a comprehensive overview of the Boc protection of primary amines, delving into the underlying mechanisms, field-proven protocols, and critical considerations for researchers, scientists, and drug development professionals.

Part 1: The Boc Group - A Mechanistic and Strategic Overview

The Chemistry of Protection: How It Works

The introduction of the Boc group onto a primary amine is a nucleophilic acyl substitution reaction. The most common reagent, di-tert-butyl dicarbonate (Boc₂O or "Boc anhydride"), serves as the electrophilic source of the Boc moiety.[2]

The mechanism proceeds as follows:

- **Nucleophilic Attack:** The lone pair of electrons on the primary amine nitrogen attacks one of the electrophilic carbonyl carbons of Boc anhydride. This forms a transient tetrahedral intermediate.[3][4]
- **Intermediate Collapse:** The tetrahedral intermediate is unstable and collapses. This results in the cleavage of the carbonate C-O bond, expelling a tert-butyl carbonate anion as a leaving group.[5]
- **Deprotonation & Byproduct Formation:** The tert-butyl carbonate anion is a moderately strong base and deprotonates the now-positively charged amine, yielding the neutral N-Boc protected amine. The anion itself is unstable and rapidly decomposes into gaseous carbon dioxide (CO₂) and tert-butoxide, which is subsequently protonated to tert-butanol.[5][6] The evolution of CO₂ gas provides a strong thermodynamic driving force for the reaction.[3]

In many protocols, a non-nucleophilic base such as triethylamine (TEA) or 4-(dimethylamino)pyridine (DMAP) is added to deprotonate the amine, increasing its nucleophilicity and reaction rate.[1][3]

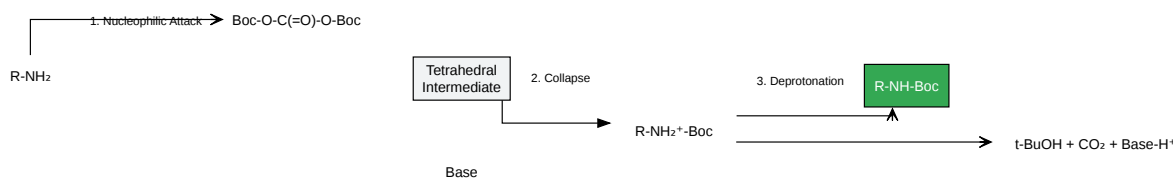

[Click to download full resolution via product page](#)

Mechanism of Boc protection of a primary amine.

Key Attributes of the Boc Group

- **Acid Lability:** The defining feature of the Boc group is its susceptibility to cleavage under acidic conditions.[7] This is due to the formation of the highly stable tert-butyl carbocation upon protonation.[4]
- **Base and Nucleophile Stability:** Boc-protected amines are exceptionally stable to a vast array of basic reagents (e.g., hydroxides, alkoxides, organometallics) and nucleophiles, making them ideal for reactions involving these species elsewhere in the molecule.[2][8]
- **Orthogonality:** The stability profile of the Boc group allows for "orthogonal" protection strategies. For instance, it is completely stable to the basic conditions (e.g., piperidine) used to remove the Fmoc group, a cornerstone of modern solid-phase peptide synthesis.[2][9]

Part 2: Experimental Protocols for Boc Protection

The conditions for Boc protection are highly flexible, allowing for adaptation to a wide range of substrates, from simple aliphatic amines to complex amino acids and poorly nucleophilic aryl amines.[1]

Reagents, Solvents, and Catalysts

Component	Common Examples	Role & Field Insights
Boc Source	Di-tert-butyl dicarbonate (Boc ₂ O)	The industry standard due to its high reactivity, stability, and commercial availability. It is a low-melting solid, sometimes handled as a solution in THF or toluene.[2][9]
2-(tert-Butoxycarbonyloxyimino)-2-phenylacetonitrile (Boc-ON)	An alternative, crystalline reagent that can be useful in specific applications but is less common than Boc ₂ O.[8][10]	
Base	Triethylamine (TEA), Diisopropylethylamine (DIPEA)	Standard, non-nucleophilic organic bases used to scavenge the proton produced and enhance amine nucleophilicity.[3]
Sodium Hydroxide (NaOH), Sodium Bicarbonate (NaHCO ₃)	Inorganic bases typically used in aqueous or biphasic systems, especially for protecting water-soluble substrates like amino acids.[1]	
4-(Dimethylamino)pyridine (DMAP)	A highly effective nucleophilic catalyst, often used in catalytic amounts (0.1 equiv) with a stoichiometric base like TEA. It is particularly useful for protecting less reactive amines, but can promote the formation of di-Boc byproducts on primary amines.[1][11][12]	
Solvent	Dichloromethane (DCM), Tetrahydrofuran (THF), Acetonitrile (ACN)	Common aprotic organic solvents that are suitable for a wide range of substrates.[1]

Dioxane/Water, THF/Water	Biphasic or aqueous systems are excellent for amino acids and other polar starting materials. [3]
--------------------------	---

Water, Methanol	Green chemistry approaches have shown that water or alcoholic solvents can mediate and even accelerate the reaction, often without the need for an added base. [13] [14]
-----------------	---

Standard Protocol: Boc Protection of an Aliphatic Amine

This protocol is a robust starting point for most primary aliphatic amines.

Materials:

- Primary amine (1.0 equiv)
- Di-tert-butyl dicarbonate (Boc₂O) (1.1 - 1.2 equiv)
- Triethylamine (TEA) (1.2 equiv)
- Dichloromethane (DCM), anhydrous

Procedure:

- **Dissolution:** Dissolve the amine substrate (1.0 equiv) in anhydrous DCM (approx. 0.2-0.5 M concentration) in a round-bottom flask equipped with a magnetic stir bar.
- **Base Addition:** Add TEA (1.2 equiv) to the solution and stir for 5 minutes at room temperature. For highly exothermic reactions, cool the mixture to 0 °C in an ice bath.
- **Reagent Addition:** Slowly add a solution of Boc₂O (1.1 equiv) in DCM to the stirring amine solution. A slight effervescence (CO₂ evolution) may be observed.

- **Reaction Monitoring:** Allow the reaction to stir at room temperature. Monitor the consumption of the starting amine by Thin Layer Chromatography (TLC) or LC-MS. Reactions are typically complete within 1-4 hours.
- **Work-up:** Upon completion, dilute the reaction mixture with DCM. Wash the organic layer sequentially with a weak acid (e.g., 1M HCl or saturated NH_4Cl) to remove excess TEA, followed by saturated aqueous NaHCO_3 , and finally brine.
- **Purification:** Dry the organic layer over anhydrous sodium sulfate (Na_2SO_4) or magnesium sulfate (MgSO_4), filter, and concentrate under reduced pressure. The resulting crude product is often pure enough for subsequent steps, but can be further purified by column chromatography on silica gel if necessary.[3]

Protocol Variation: Protection of an Amino Acid in Aqueous Media

Materials:

- Amino acid (1.0 equiv)
- Di-tert-butyl dicarbonate (Boc_2O) (1.1 equiv)
- Sodium hydroxide (NaOH) (2.0 equiv)
- Dioxane (or THF) and Water

Procedure:

- **Dissolution:** Dissolve the amino acid (1.0 equiv) in a 1:1 mixture of dioxane and 1M aqueous NaOH solution (containing 2.0 equiv of NaOH). Cool the solution to 0 °C.
- **Reagent Addition:** Add Boc_2O (1.1 equiv), either neat or as a solution in dioxane, to the vigorously stirring mixture.
- **Reaction:** Allow the mixture to warm to room temperature and stir overnight.

- Work-up: Concentrate the mixture in vacuo to remove the dioxane. Dilute the remaining aqueous solution with water and wash with a nonpolar solvent (e.g., ether or ethyl acetate) to remove any unreacted Boc₂O and tert-butanol.
- Acidification & Extraction: Cool the aqueous layer to 0 °C and carefully acidify to pH 2-3 with cold 1M HCl or citric acid solution. The Boc-protected amino acid will typically precipitate or can be extracted with an organic solvent like ethyl acetate.
- Purification: Dry the combined organic extracts over Na₂SO₄, filter, and evaporate the solvent to yield the product.[\[3\]](#)[\[15\]](#)

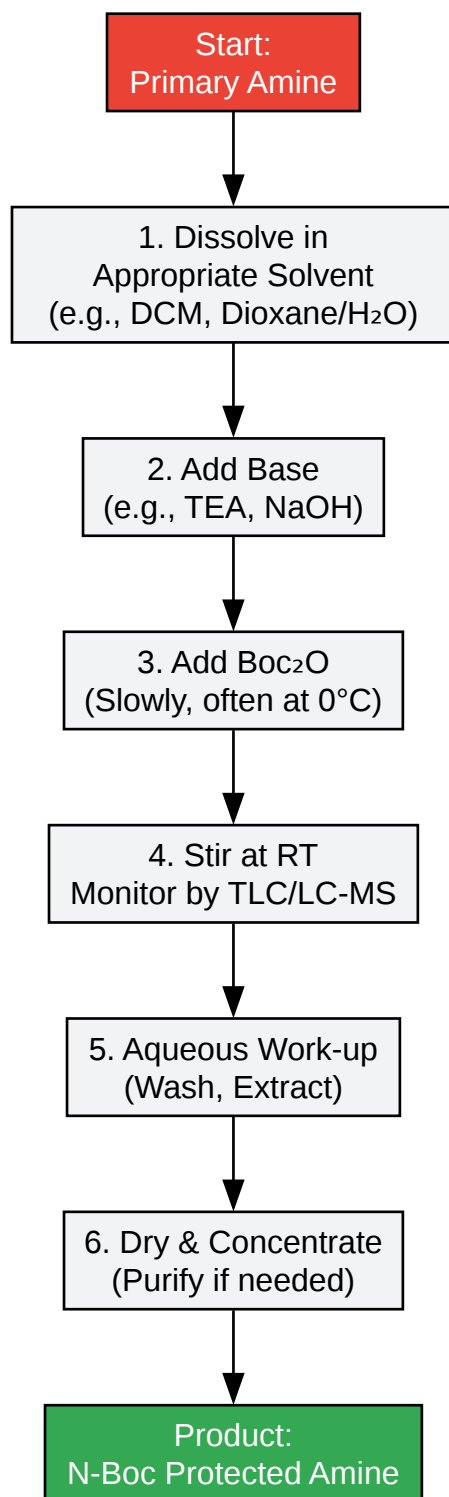

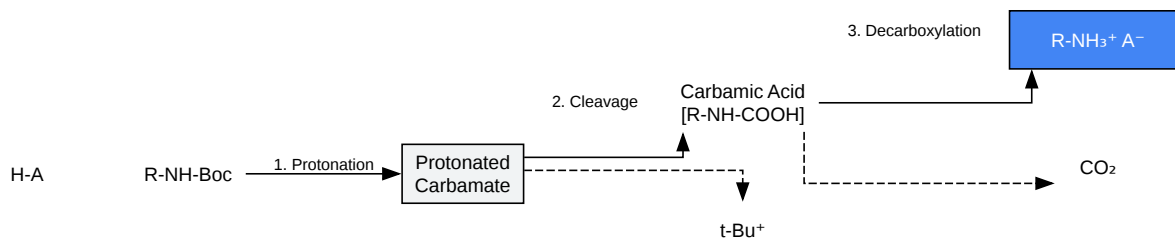

[Click to download full resolution via product page](#)

Mechanism of acid-catalyzed Boc deprotection.

The Fate of the tert-Butyl Cation: The Role of Scavengers

The tert-butyl cation generated during deprotection is a potent electrophile. In the presence of other nucleophilic functional groups within the substrate (e.g., the indole ring of tryptophan or the thioether of methionine), it can cause undesired alkylation side reactions. To prevent this, a "scavenger" is often added to the deprotection mixture. Scavengers are nucleophiles designed to trap the carbocation. [2][16] Common Scavengers:

- Anisole or Thioanisole
- Triethylsilane (TES)
- Water

Standard Protocol: Deprotection with TFA in DCM

This is the most common and reliable method for Boc cleavage.

Materials:

- N-Boc protected amine
- Trifluoroacetic acid (TFA)

- Dichloromethane (DCM)
- Scavenger (e.g., anisole), if required

Procedure:

- **Dissolution:** Dissolve the Boc-protected substrate in DCM (approx. 0.1-0.2 M). Cool the solution to 0 °C in an ice bath.
- **Reagent Addition:** Slowly add TFA to the solution. A common formulation is a 25-50% solution of TFA in DCM (v/v). [3][17] If the substrate is sensitive or contains nucleophilic residues, include a scavenger (e.g., 5% anisole).
- **Reaction:** Stir the reaction at room temperature. Effervescence (CO₂) is a positive sign that the reaction is proceeding. [6] Monitor the reaction by TLC or LC-MS until the starting material is fully consumed (typically 30 minutes to 2 hours).
- **Work-up:** Upon completion, remove the solvent and excess TFA under reduced pressure. It is common practice to co-evaporate with a solvent like toluene or DCM several times to ensure all residual TFA is removed.
- **Isolation:** The product is obtained as the TFA salt, which is often a solid or oil. It can be used directly in the next step or neutralized by washing with a mild aqueous base (e.g., NaHCO₃) and extracting the free amine into an organic solvent. [17][18]

Alternative Deprotection Conditions

For substrates that are sensitive to the harshness of neat TFA, several milder alternatives exist.

Reagent(s)	Solvent(s)	Typical Use Case & Rationale
4M HCl	Dioxane, Ethyl Acetate, or Methanol	A common, less volatile, and cheaper alternative to TFA. The resulting amine hydrochloride salt is often a crystalline solid, which can aid in purification. [1][16]
Trimethylsilyl iodide (TMSI)	Acetonitrile or DCM	A very mild, neutral method for deprotection, useful when other acid-labile groups must be preserved. The reaction is followed by a methanol quench. [16][19]
Lewis Acids (e.g., ZnBr ₂ , AlCl ₃)	Dichloromethane (DCM)	Offers selectivity. For example, ZnBr ₂ can selectively cleave secondary N-Boc groups in the presence of primary ones. [20][19]
Thermal	High-boiling solvent or neat	Heating a Boc-protected amine (typically >80 °C, sometimes up to 180 °C) can induce thermal cleavage, though this is less common due to potential side reactions. [16][21]

Part 4: Field-Proven Insights and Troubleshooting

- Challenge: Incomplete protection of a weakly nucleophilic amine (e.g., an aniline).
 - Insight: Aryl amines are significantly less reactive than aliphatic amines. [11] Simply extending reaction time is often inefficient.

- Solution: Add a catalytic amount of DMAP (5-10 mol%) to your standard conditions. Alternatively, increasing the reaction temperature to reflux may be necessary. For particularly stubborn cases, a two-step procedure of exhaustive di-Boc protection followed by selective mono-deprotection can yield the desired product. [11]
- Challenge: Formation of an N,N-di-Boc byproduct with a primary amine.
 - Insight: This side reaction is favored by highly reactive conditions, such as the use of stoichiometric DMAP or prolonged reaction times with a large excess of Boc₂O. [12][22] * Solution: Use only a catalytic amount of DMAP. Ensure the stoichiometry of Boc₂O is kept close to 1.1 equivalents. If the di-Boc product forms, one Boc group can often be selectively removed under milder acidic conditions than those required to cleave the second. [11]
- Challenge: Side-product formation during deprotection of a peptide.
 - Insight: The tert-butyl cation is the culprit. It will readily alkylate electron-rich aromatic rings (tryptophan) and sulfur atoms (methionine). [16] * Solution: Always include a scavenger in the deprotection cocktail. A standard mixture for peptides is 95% TFA, 2.5% water, and 2.5% triisopropylsilane (TIS).
- Challenge: Difficulty removing residual Boc₂O from a non-polar product.
 - Insight: Boc₂O is non-polar and can co-elute with products during chromatography.
 - Solution: After the reaction, concentrate the crude mixture and place it under high vacuum for an extended period (24-72 hours). The Boc₂O will slowly sublime and collect in a cold trap, providing a simple, non-chromatographic purification method. [23]

Conclusion

The Boc group represents a pillar of modern synthetic chemistry, providing a reliable and highly versatile method for the protection of primary amines. Its predictable stability and the straightforward nature of its installation and removal have cemented its role in the synthesis of countless pharmaceuticals, agrochemicals, and complex organic molecules. By understanding the core mechanisms, mastering the standard protocols, and being aware of the nuances for

challenging substrates, researchers can effectively leverage the power of the Boc protecting group to streamline their synthetic endeavors and accelerate the pace of discovery.

References

- Organic Chemistry Portal. Boc-Protected Amino Groups. [\[Link\]](#)
- Wikipedia. tert-Butyloxycarbonyl protecting group. [\[Link\]](#)
- Common Organic Chemistry. Boc Protection Mechanism (Boc₂O). [\[Link\]](#)
- Common Organic Chemistry. Boc Deprotection Mechanism - TFA. [\[Link\]](#)
- National Center for Biotechnology Information. A One-Pot Selective Synthesis of N-Boc Protected Secondary Amines. [\[Link\]](#)
- Fiveable. Acid-Labile Protecting Groups Definition - Organic Chemistry Key Term. [\[Link\]](#)
- Taylor & Francis Online. AN IMPROVED SYNTHESIS OF N-BOC PROTECTED ARYL AMINES. [\[Link\]](#)
- ResearchGate. Acid-labile protecting groups. [\[Link\]](#)
- National Center for Biotechnology Information. Acid-labile protecting groups for the synthesis of lipidated peptides. [\[Link\]](#)
- Wikipedia. Di-tert-butyl dicarbonate. [\[Link\]](#)
- Hebei Boze Chemical Co., Ltd. Di-Tert-Butyl Dicarbonate. [\[Link\]](#)
- Master Organic Chemistry. Amine Protection and Deprotection. [\[Link\]](#)
- Chemistry Steps. Boc Protecting Group for Amines. [\[Link\]](#)
- Hebei Boze Chemical Co.,Ltd. BOC deprotection. [\[Link\]](#)
- National Center for Biotechnology Information. N-tert-Butoxycarbonylation of Structurally Diverse Amines and Sulfamides under Water-Mediated Catalyst-Free Conditions. [\[Link\]](#)

- Royal Society of Chemistry. Dual protection of amino functions involving Boc. [[Link](#)]
- J&K Scientific LLC. BOC Protection and Deprotection. [[Link](#)]
- Common Organic Chemistry. Boc Deprotection - TFA. [[Link](#)]
- WordPress.com. Reactions that Work: Boc Protection | Chemtips. [[Link](#)]
- SpringerLink. Mild deprotection of the N-tert-butyloxycarbonyl (N-Boc) group using oxalyl chloride. [[Link](#)]
- ACS Publications. Di-tert-butyl Dicarboxylate and 4-(Dimethylamino)pyridine Revisited. Their Reactions with Amines and Alcohols. [[Link](#)]
- Der Pharma Chemica. Solvent-free, instant, ambient, n-boc protection of amines -A green, recyclable heterogenous acid catalysis. [[Link](#)]
- WuXi Biology. Alcohol Speed up Boc Protection of Primary Amines. [[Link](#)]
- YouTube. Boc Deprotection Mechanism | Organic Chemistry. [[Link](#)]
- Wikipedia. Protecting group. [[Link](#)]
- ACS Publications. Some novel, acid-labile amine protecting groups. [[Link](#)]
- Chemistry Stack Exchange. What happens to the t-butyl cation in the TFA deprotection of a t-butyl ester?. [[Link](#)]
- Beilstein Journals. EXPERIMENTAL PROCEDURES. [[Link](#)]
- The Royal Society of Chemistry. SUPPORTING INFORMATION. [[Link](#)]

Need Custom Synthesis?

BenchChem offers custom synthesis for rare earth carbides and specific isotopic labeling.

Email: info@benchchem.com or [Request Quote Online](#).

Sources

- [1. Amine Protection / Deprotection \[fishersci.co.uk\]](#)
- [2. Di-tert-butyl dicarbonate - Wikipedia \[en.wikipedia.org\]](#)
- [3. pdf.benchchem.com \[pdf.benchchem.com\]](#)
- [4. Boc Protecting Group for Amines - Chemistry Steps \[chemistrysteps.com\]](#)
- [5. Boc Protection Mechanism \(Boc2O\) \[commonorganicchemistry.com\]](#)
- [6. masterorganicchemistry.com \[masterorganicchemistry.com\]](#)
- [7. fiveable.me \[fiveable.me\]](#)
- [8. Boc-Protected Amino Groups \[organic-chemistry.org\]](#)
- [9. Di-Tert-Butyl Dicarbonate \[bzchemicals.com\]](#)
- [10. pdf.benchchem.com \[pdf.benchchem.com\]](#)
- [11. tandfonline.com \[tandfonline.com\]](#)
- [12. pubs.acs.org \[pubs.acs.org\]](#)
- [13. wuxibiology.com \[wuxibiology.com\]](#)
- [14. N-tert-Butoxycarbonylation of Structurally Diverse Amines and Sulfamides under Water-Mediated Catalyst-Free Conditions - PMC \[pmc.ncbi.nlm.nih.gov\]](#)
- [15. BOC deprotection \[ms.bzchemicals.com\]](#)
- [16. tert-Butyloxycarbonyl protecting group - Wikipedia \[en.wikipedia.org\]](#)
- [17. Boc Deprotection - TFA \[commonorganicchemistry.com\]](#)
- [18. rsc.org \[rsc.org\]](#)
- [19. Amine Protection / Deprotection \[fishersci.dk\]](#)
- [20. jk-sci.com \[jk-sci.com\]](#)
- [21. Protecting group - Wikipedia \[en.wikipedia.org\]](#)
- [22. Dual protection of amino functions involving Boc - RSC Advances \(RSC Publishing\) DOI:10.1039/C3RA42956C \[pubs.rsc.org\]](#)
- [23. chemtips.wordpress.com \[chemtips.wordpress.com\]](#)
- To cite this document: BenchChem. [Introduction to Boc protection of primary amines]. BenchChem, [2026]. [Online PDF]. Available at:

[\[https://www.benchchem.com/product/b1451272/docs#introduction-to-boc-protection-of-primary-amines\]](https://www.benchchem.com/product/b1451272/docs#introduction-to-boc-protection-of-primary-amines)

Disclaimer & Data Validity:

The information provided in this document is for Research Use Only (RUO) and is strictly not intended for diagnostic or therapeutic procedures. While BenchChem strives to provide accurate protocols, we make no warranties, express or implied, regarding the fitness of this product for every specific experimental setup.

Technical Support: The protocols provided are for reference purposes. Unsure if this reagent suits your experiment?

Need Industrial/Bulk Grade? [Request Custom Synthesis Quote](#)

BenchChem

Our mission is to be the trusted global source of essential and advanced chemicals, empowering scientists and researchers to drive progress in science and industry.

Contact

Address: 3281 E Guasti Rd
Ontario, CA 91761, United States
Phone: (601) 213-4426
Email: info@benchchem.com

[Contact our Ph.D. Support Team for a compatibility check](#)