

# Exploratory Synthesis of Substituted Phenylacetonitriles: A Technical Guide

**Author:** BenchChem Technical Support Team. **Date:** May 2026

## Compound of Interest

Compound Name: 2-Methoxy-4-(trifluoromethyl)phenylacetonitrile  
CAS No.: 1017779-20-2  
Cat. No.: B1451934

[Get Quote](#)

## Executive Summary & Strategic Importance

Substituted phenylacetonitriles (benzyl cyanides) are linchpin intermediates in the synthesis of isoquinoline alkaloids, non-steroidal anti-inflammatory drugs (NSAIDs), and varying classes of antidepressants. Their structural versatility lies in the bifunctional nature of the molecule: the aromatic ring allows for electronic tuning via substitution, while the nitrile group serves as a gateway to acids, amides, amines, and aldehydes, or as a masked nucleophile for alpha-alkylation.

This guide moves beyond standard textbook preparations to explore three distinct synthetic paradigms tailored to the electronic and steric demands of modern drug discovery:

- Classical Phase-Transfer Catalysis (PTC): The robust standard for benzyl halides.
- Palladium-Catalyzed
  - Arylation: The precision route for aryl halides.

- Vicarious Nucleophilic Substitution (VNS): The direct functionalization of electron-deficient arenes.

## Strategic Route Selection

The choice of synthetic pathway is dictated by the availability of the starting material and the electronic character of the aromatic ring.

### Decision Matrix: Pathway Selection

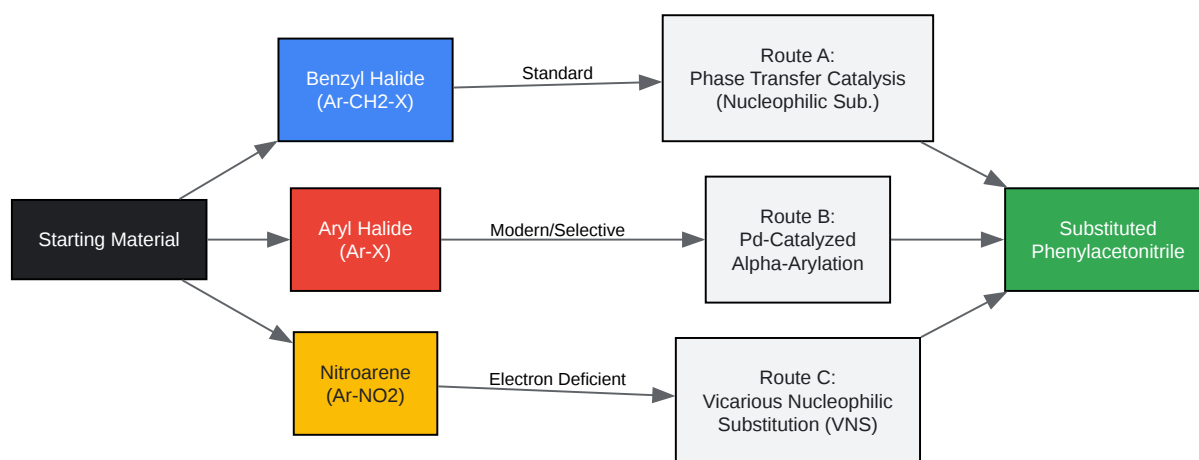

[Click to download full resolution via product page](#)

Figure 1: Strategic decision tree for selecting the optimal synthetic pathway based on substrate availability.

## Route A: Phase Transfer Catalyzed (PTC) Cyanation

Best for: Benzyl chlorides/bromides; Scale-up; Cost-efficiency.[1]

The classical reaction of benzyl halides with alkali cyanides in homogenous solvents (EtOH/Water) often suffers from slow rates and hydrolysis side reactions. Phase Transfer Catalysis (PTC) solves this by shuttling cyanide ions into the organic phase, enhancing reactivity and minimizing water-induced hydrolysis.

## Mechanistic Insight

In a biphasic system (e.g., Toluene/Water), the quaternary ammonium catalyst ( ) exchanges its halide anion for a cyanide ion at the interface. The lipophilic ion pair ( ) migrates into the organic phase, where the "naked" cyanide is highly nucleophilic due to poor solvation, rapidly displacing the halide on the substrate.

## Protocol 1: PTC Synthesis of 3,4-Dimethoxyphenylacetonitrile

Target: Precursor for Verapamil/Papaverine analogues.<sup>[1]</sup>

Reagents:

- 3,4-Dimethoxybenzyl chloride (1.0 eq)
- Sodium Cyanide (NaCN) (1.2 eq) [DANGER: See Safety Section]
- Tetrabutylammonium bromide (TBAB) (0.05 eq)
- Solvent: Toluene / Water (1:1 v/v)

Step-by-Step Methodology:

- Preparation: In a 3-neck flask equipped with a mechanical stirrer and reflux condenser, dissolve NaCN (1.2 eq) in water (3 mL/g of NaCN).
- Catalyst Addition: Add TBAB (5 mol%) to the aqueous solution.
- Organic Phase: Dissolve the benzyl chloride substrate in toluene (3 mL/g substrate) and add to the reactor.
- Reaction: Heat the biphasic mixture to 60°C with vigorous stirring (>800 rpm) to maximize interfacial area. Monitor by TLC/HPLC.
- Quench: Cool to RT. Add dilute NaOH (10%) to maintain pH >10 (prevents HCN formation).

- Workup: Separate phases. Wash organic layer with water (2x) and brine. Dry over MgSO<sub>4</sub>.
- Purification: Remove solvent in vacuo. Purify via vacuum distillation or recrystallization (EtOH).

Data Summary: Solvent Effects on Yield

Solvent System	Catalyst	Time (h)	Yield (%)	Notes
EtOH / H <sub>2</sub> O	None	12	65	Significant hydrolysis byproduct
Toluene / H <sub>2</sub> O	TBAB	4	92	Clean conversion
DCM / H <sub>2</sub> O	TEBA	6	88	Good for thermally sensitive substrates

## Route B: Palladium-Catalyzed $\alpha$ -Arylation

Best for: Aryl halides (Cl/Br/I); Accessing sterically hindered nitriles.

When benzyl halides are unstable or unavailable, constructing the C-C bond directly from an aryl halide and acetonitrile (or a cyanoacetate surrogate) is the superior strategy. This method relies on the acidity of the nitrile

-protons (

in DMSO) and the ability of Pd(II) to facilitate reductive elimination.

### Mechanistic Workflow

The cycle involves oxidative addition of the aryl halide to Pd(0), followed by transmetalation with a nitrile enolate (generated in situ by a base like LiHMDS or NaOtBu), and finally reductive elimination to form the Ar-CH<sub>2</sub>-CN bond.

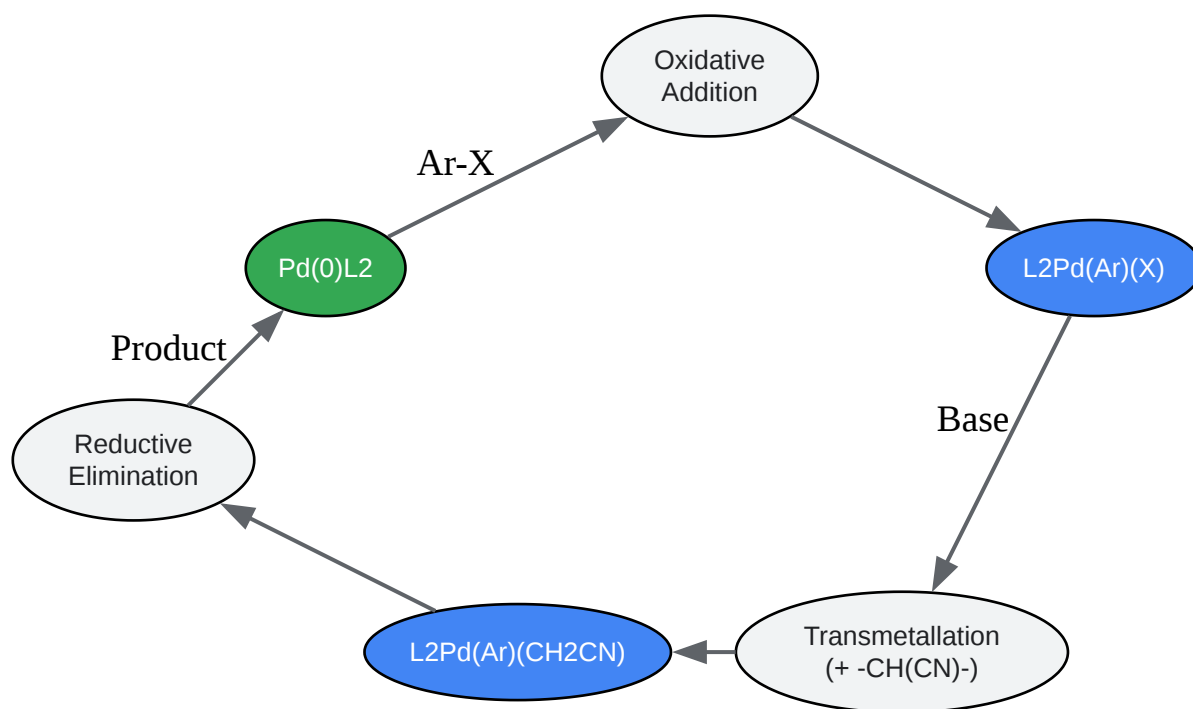

[Click to download full resolution via product page](#)

Figure 2: Catalytic cycle for the Pd-catalyzed

-arylation of nitriles.

## Protocol 2: Coupling of Aryl Bromides with Cyanoacetate

Note: Direct coupling with acetonitrile can be sluggish; using t-butyl cyanoacetate followed by decarboxylation is often higher yielding.

Reagents:

- Aryl Bromide (1.0 eq)
- tert-Butyl Cyanoacetate (1.1 eq)
- $\text{Pd}(\text{dba})_2$  (1-2 mol%)
- Ligand:  $\text{P}(\text{t-Bu})_3$  or Xantphos (2-4 mol%)

- Base: Na<sub>3</sub>PO<sub>4</sub> or K<sub>3</sub>PO<sub>4</sub> (anhydrous)
- Solvent: Toluene or THF

#### Step-by-Step Methodology:

- Coupling: Combine Aryl Bromide, Cyanoacetate, Base, and Catalyst in a glovebox or under Argon. Reflux in Toluene for 12h.
- Decarboxylation: Filter the mixture and concentrate. Treat the intermediate (-cyano ester) with TFA/DCM (1:1) at RT to cleave the t-butyl group, followed by heating (80°C) to effect decarboxylation.
- Result: Pure substituted phenylacetonitrile.

## Route C: Vicarious Nucleophilic Substitution (VNS)

Best for: Nitroarenes; Introducing -CH<sub>2</sub>CN into electron-deficient rings without halides.

VNS is a powerful, underutilized method where a carbanion bearing a leaving group reacts with a nitroarene. The reaction proceeds via addition to the aromatic ring followed by

-elimination of the leaving group, effectively replacing a hydrogen atom.

Key Reagent: Chloromethyl phenyl sulfone (

) is typically used as a "cyanomethyl anion equivalent" precursor, but direct cyanomethylation is possible using specific reagents like (cyanomethyl)trimethylphosphonium iodide or sulfonyl acetonitriles.

#### General VNS Protocol:

- Substrate: Nitrobenzene derivative.
- Nucleophile: Chloromethyl phenyl sulfone (1.1 eq).
- Base: NaOH or t-BuOK (2.5 eq) in DMSO or DMF.

- Mechanism: The carbanion adds ortho or para to the nitro group. Elimination of HCl restores aromaticity.
- Post-Processing: The resulting sulfone ( ) can be reductively desulfonylated or converted to nitrile via specific functional group manipulations if direct cyanomethylation reagents are not used.

## Process Safety & Engineering

Handling cyanides requires rigorous safety protocols. The "exploratory" nature of research never justifies bypassing safety engineering.

## Cyanide Handling "Golden Rules"

- pH Control: Never allow the pH of a cyanide solution to drop below 10. Acidification releases HCN gas (IDLH = 50 ppm).
- Quenching: All cyanide waste must be quenched with Sodium Hypochlorite (Bleach) or Hydrogen Peroxide at pH >11 before disposal.
  - Reaction:  
  
(Cyanate is 1000x less toxic).
- Antidote: A Cyanokit (Hydroxocobalamin) must be physically present in the lab.

## Continuous Flow Chemistry

For scale-up, converting the batch PTC process to a continuous flow reactor (e.g., packed bed with solid supported catalyst) significantly reduces the active inventory of HCN/Cyanide, improving the safety profile.

## References

- Makosza, M., & Wawrzyniewicz, M. (1969). Reactions of organic anions.[2][3] XXIV. Catalytic method for preparation of dichlorocyclopropane derivatives in aqueous medium. Tetrahedron Letters. [Link](#) (Foundational PTC work).

- Culkin, D. A., & Hartwig, J. F. (2002). Palladium-Catalyzed  $\alpha$ -Arylation of Carbonyl Compounds and Nitriles. *Accounts of Chemical Research*, 36(4), 234–245. [Link](#)
- Starks, C. M. (1971). Phase-transfer catalysis.[1][4][5] I. Heterogeneous reactions involving anion transfer by quaternary ammonium and phosphonium salts. *Journal of the American Chemical Society*, 93(1), 195-199. [Link](#)
- Makosza, M., & Winiarski, J. (1987). Vicarious nucleophilic substitution of hydrogen.[2][6][7][8] *Accounts of Chemical Research*, 20(8), 282–289. [Link](#)
- BenchChem. (2025).[4] Continuous Flow Synthesis of Phenylacetonitrile: Application Notes.[Link](#) (Modern flow protocols).
- Organic Syntheses. (1922). Benzyl Cyanide.[1][5][9][10][11][12] *Org. Synth.* 2, 9. [Link](#) (Classical baseline).

### Need Custom Synthesis?

BenchChem offers custom synthesis for rare earth carbides and specific isotopic labeling.

Email: [info@benchchem.com](mailto:info@benchchem.com) or [Request Quote Online](#).

## Sources

- 1. [phasetransfer.com](https://phasetransfer.com) [[phasetransfer.com](https://phasetransfer.com)]
- 2. Alkylation of Nitropyridines via Vicarious Nucleophilic Substitution - PMC [[pmc.ncbi.nlm.nih.gov](https://pubmed.ncbi.nlm.nih.gov/)]
- 3. [researchgate.net](https://www.researchgate.net) [[researchgate.net](https://www.researchgate.net)]
- 4. [pdf.benchchem.com](https://pdf.benchchem.com) [[pdf.benchchem.com](https://pdf.benchchem.com)]
- 5. [researchgate.net](https://www.researchgate.net) [[researchgate.net](https://www.researchgate.net)]
- 6. [chem.kuleuven.be](https://chem.kuleuven.be) [[chem.kuleuven.be](https://chem.kuleuven.be)]
- 7. Vicarious Nucleophilic Substitution [[organic-chemistry.org](https://www.organic-chemistry.org)]
- 8. Alkylation of Nitropyridines via Vicarious Nucleophilic Substitution - PMC [[pmc.ncbi.nlm.nih.gov](https://pubmed.ncbi.nlm.nih.gov/)]
- 9. Phenylacetonitrile | C<sub>8</sub>H<sub>7</sub>N | CID 8794 - PubChem [[pubchem.ncbi.nlm.nih.gov](https://pubchem.ncbi.nlm.nih.gov/)]

- [10. Organic Syntheses Procedure \[orgsyn.org\]](#)
- [11. US2783265A - Preparation of phenylacetonitriles - Google Patents \[patents.google.com\]](#)
- [12. Organic Syntheses Procedure \[orgsyn.org\]](#)
- [13. Palladium-catalyzed alpha-Arylation of Esters, Ketones, Amides and Imides \[organic-chemistry.org\]](#)
- To cite this document: BenchChem. [Exploratory Synthesis of Substituted Phenylacetonitriles: A Technical Guide]. BenchChem, [2026]. [Online PDF]. Available at: [<https://www.benchchem.com/product/b1451934/docs#exploratory-synthesis-of-substituted-phenylacetonitriles-a-technical-guide>]

---

### Disclaimer & Data Validity:

The information provided in this document is for Research Use Only (RUO) and is strictly not intended for diagnostic or therapeutic procedures. While BenchChem strives to provide accurate protocols, we make no warranties, express or implied, regarding the fitness of this product for every specific experimental setup.

**Technical Support:** The protocols provided are for reference purposes. Unsure if this reagent suits your experiment?

**Need Industrial/Bulk Grade?** [Request Custom Synthesis Quote](#)

## BenchChem

Our mission is to be the trusted global source of essential and advanced chemicals, empowering scientists and researchers to drive progress in science and industry.

### Contact

Address: 3281 E Guasti Rd  
Ontario, CA 91761, United States  
Phone: (601) 213-4426  
Email: [info@benchchem.com](mailto:info@benchchem.com)

Contact our Ph.D. Support Team for a compatibility check