

# Decoding the Magnesium-RCK Domain Interaction in BK Channels: A Comparative Guide

**Author:** BenchChem Technical Support Team. **Date:** May 2026

## Compound of Interest

Compound Name:	Magnesium;potassium
CAS No.:	65380-44-1
Cat. No.:	B14494520

[Get Quote](#)

For Researchers, Scientists, and Drug Development Professionals

This guide provides a comprehensive comparison of experimental approaches used to confirm and characterize the interaction between magnesium ions ( $Mg^{2+}$ ) and the Regulators of Conductance of  $K^+$  (RCK) domain of large-conductance  $Ca^{2+}$ -activated  $K^+$  (BK) channels. Understanding this interaction is crucial for elucidating the channel's gating mechanisms and for the development of novel therapeutics targeting BK channel function.

## Unveiling the $Mg^{2+}$ Binding Site and a Unique Gating Mechanism

Large-conductance  $Ca^{2+}$ -activated  $K^+$  (BK) channels are crucial regulators of cellular excitability, involved in processes ranging from neuronal firing to smooth muscle contraction.[1][2][3][4] Their activation is synergistically controlled by membrane depolarization and intracellular divalent cations, including both calcium ( $Ca^{2+}$ ) and magnesium ( $Mg^{2+}$ ).[1][2][3][4][5] While the role of  $Ca^{2+}$  in activating BK channels via binding to two distinct sites in the C-

terminal domain is well-established,  $Mg^{2+}$  modulates channel activity through a separate, lower-affinity binding site.[5][6]

Experimental evidence has pinpointed the  $Mg^{2+}$  binding site to a novel interfacial cleft formed between the membrane-spanning voltage sensor domain (VSD) and the cytoplasmic RCK1 domain.[1][7] This interaction is not a simple binding event but rather a sophisticated mechanism where the bound  $Mg^{2+}$  electrostatically interacts with the voltage sensor, thereby facilitating channel opening.[1][5][8] This guide will delve into the experimental methodologies that have been pivotal in confirming this interaction and compare it with alternative activation mechanisms.

## Comparative Analysis of Experimental Approaches

Several key experimental techniques have been instrumental in defining the molecular basis of the  $Mg^{2+}$ -RCK domain interaction. Below is a comparison of these methods, highlighting their contributions and limitations.

Experimental Technique	Principle	Key Findings for Mg <sup>2+</sup> -RCK Interaction	Alternative Approaches & Considerations
Electrophysiology (Inside-Out Patch-Clamp)	Measures ion flow across a small patch of cell membrane containing the channel of interest. Allows for the precise control of the intracellular solution, including Mg <sup>2+</sup> concentration, and membrane voltage.	<ul style="list-style-type: none"> <li>- Confirmed that intracellular Mg<sup>2+</sup> shifts the conductance-voltage (G-V) relationship of BK channels to more negative potentials, indicating that less depolarization is required for channel opening in the presence of Mg<sup>2+</sup>.<sup>[1]</sup></li> <li><sup>[3]</sup><sup>[8]</sup> - Quantified the voltage sensitivity (V<sup>1/2</sup>) shifts induced by varying Mg<sup>2+</sup> concentrations.<sup>[1]</sup></li> <li>- Demonstrated that the effect of Mg<sup>2+</sup> is dependent on voltage sensor activation.<sup>[8]</sup></li> </ul>	<ul style="list-style-type: none"> <li>- Whole-cell patch-clamp: Provides a more physiological context but offers less control over the intracellular environment.</li> <li>- Single-channel recording: Provides insights into the kinetic effects of Mg<sup>2+</sup> on channel gating, such as changes in open and closed times.<sup>[9]</sup></li> </ul>
Site-Directed Mutagenesis	Involves altering specific amino acid residues within the channel protein to assess their contribution to function.	<ul style="list-style-type: none"> <li>- Identified key acidic residues in the RCK1 domain (E374, E399) and the VSD (D99, N172) as essential for Mg<sup>2+</sup> sensing.<sup>[1]</sup><sup>[3]</sup><sup>[7]</sup></li> <li><sup>[10]</sup> - Mutation of these residues to neutral amino acids abolishes or significantly reduces the channel's</li> </ul>	<ul style="list-style-type: none"> <li>- Alanine scanning mutagenesis: Systematically replacing residues with alanine can provide a broader overview of important functional regions.</li> <li>- Charge-swapping mutations: Reversing the charge of key residues can provide</li> </ul>

		<p>sensitivity to Mg<sup>2+</sup> without affecting its sensitivity to Ca<sup>2+</sup>.<a href="#">[3]</a> <a href="#">[4]</a><a href="#">[10]</a></p>	<p>evidence for electrostatic interactions.<a href="#">[7]</a></p>
Structural Biology (Homology Modeling & Cryo-EM)	<p>Predicts the three-dimensional structure of the BK channel based on the known structures of related ion channels (e.g., MthK).<a href="#">[1]</a><a href="#">[11]</a><a href="#">[12]</a> Cryo-electron microscopy (cryo-EM) provides high-resolution structural snapshots of the channel in different conformational states.</p>	<p>- Structural models based on the MthK channel provided the initial framework for understanding the spatial arrangement of the VSD and RCK domains.<a href="#">[1]</a><a href="#">[13]</a> - These models predicted the proximity of the identified Mg<sup>2+</sup>-coordinating residues, supporting the formation of an inter-domain binding pocket.<a href="#">[1]</a> - Recent cryo-EM structures have provided a more detailed view of the overall architecture of the BK channel, confirming the close apposition of the VSD and the cytoplasmic "gating ring" formed by the RCK domains. <a href="#">[13]</a></p>	<p>- X-ray crystallography: Can provide atomic-resolution structures but requires obtaining well-ordered crystals, which can be challenging for large membrane proteins. <a href="#">[11]</a><a href="#">[12]</a></p>
Fluorescence Resonance Energy Transfer (FRET)	<p>Measures the distance-dependent transfer of energy between two fluorescent molecules</p>	<p>- FRET studies have shown that the binding of divalent cations, including Mg<sup>2+</sup>, induces</p>	<p>- Voltage-clamp fluorometry: Combines electrophysiology with fluorescence</p>

(donor and acceptor) attached to different parts of the channel. conformational changes within the RCK gating ring.[14] - These studies have also demonstrated that the conformational state of the gating ring is coupled to the movement of the voltage sensor.[14] measurements to simultaneously track channel activity and conformational changes in real-time. [15]

## Quantitative Data Summary

The following tables summarize key quantitative data from electrophysiological and mutagenesis studies investigating the Mg<sup>2+</sup>-RCK domain interaction.

Table 1: Effect of Mg<sup>2+</sup> on the Voltage Dependence of BK Channel Activation

Channel Type	[Mg <sup>2+</sup> ] (mM)	V <sub>1/2</sub> (mV)	ΔV <sub>1/2</sub> (mV)	Reference
Wild-type mSlo1	0	+150	-	[1]
Wild-type mSlo1	10	+80	-70	[1]
E374A mutant	10	+145	-5	[3]
E399N mutant	10	+148	-2	[3]
D99A mutant	10	+140	-10	[1]

Table 2: Comparison of Mg<sup>2+</sup> and Ca<sup>2+</sup> Sensitivity in Wild-Type and Mutant BK Channels

Channel Type	Ligand	EC <sub>50</sub>	Hill Coefficient	Reference
Wild-type mSlo1	Mg <sup>2+</sup>	~2-3 mM	~1.5	[8]
Wild-type mSlo1	Ca <sup>2+</sup>	~5-10 μM	~2	[16]
E374A/E399N mutant	Mg <sup>2+</sup>	> 30 mM	N/A	[3]
E374A/E399N mutant	Ca <sup>2+</sup>	~5-10 μM	~2	[3]

## Detailed Experimental Protocols

A detailed understanding of the experimental methodologies is crucial for reproducing and building upon these findings.

### Inside-Out Patch-Clamp Electrophysiology

This technique is the gold standard for studying the effects of intracellular ligands on ion channel activity.

- **Cell Preparation:** HEK293 cells or *Xenopus* oocytes are transiently transfected with the cDNA encoding the BK channel  $\alpha$ -subunit (and  $\beta$ -subunits if desired).
- **Pipette Preparation:** Borosilicate glass capillaries are pulled to create micropipettes with a resistance of 2-5 M $\Omega$  when filled with the pipette solution. The pipette solution typically contains (in mM): 140 potassium methanesulfonate, 20 HEPES, 2 KCl, 2 MgCl<sub>2</sub>, pH 7.2.
- **Patch Formation:** A high-resistance "giga-seal" is formed between the pipette tip and the cell membrane.
- **Inside-Out Configuration:** The pipette is pulled away from the cell, excising a small patch of membrane with the intracellular side now facing the bath solution.
- **Solution Exchange:** A perfusion system is used to rapidly exchange the bath solution, allowing for the application of different concentrations of MgCl<sub>2</sub> to the intracellular face of the channel. The basal internal solution typically contains (in mM): 140 potassium methanesulfonate, 20 HEPES, 2 KCl, pH 7.2.

- **Data Acquisition:** Macroscopic currents are recorded in response to voltage steps using a patch-clamp amplifier. Conductance-voltage (G-V) curves are generated by plotting the normalized tail current as a function of the prepulse voltage.
- **Data Analysis:** G-V curves are fitted with a Boltzmann function to determine the half-maximal activation voltage ( $V_{1/2}$ ) and the steepness of the voltage dependence (slope factor).

## Site-Directed Mutagenesis

This method allows for the targeted alteration of the channel's amino acid sequence.

- **Plasmid Template:** A plasmid containing the wild-type BK channel cDNA is used as a template.
- **Primer Design:** Two complementary oligonucleotide primers are designed, each containing the desired mutation.
- **PCR Amplification:** The entire plasmid is amplified using a high-fidelity DNA polymerase and the mutagenic primers.
- **Template Digestion:** The parental, methylated DNA template is digested with the DpnI restriction enzyme.
- **Transformation:** The newly synthesized, mutated plasmids are transformed into competent *E. coli* for amplification.
- **Sequence Verification:** The entire coding region of the mutated channel is sequenced to confirm the desired mutation and the absence of any unintended mutations.
- **Functional Expression:** The mutated plasmid is then used for expression in a suitable system (e.g., HEK293 cells or *Xenopus oocytes*) for functional characterization using techniques like patch-clamp electrophysiology.

## Visualizing the Molecular Mechanisms

Diagrams are essential for conceptualizing the complex signaling pathways and experimental workflows.

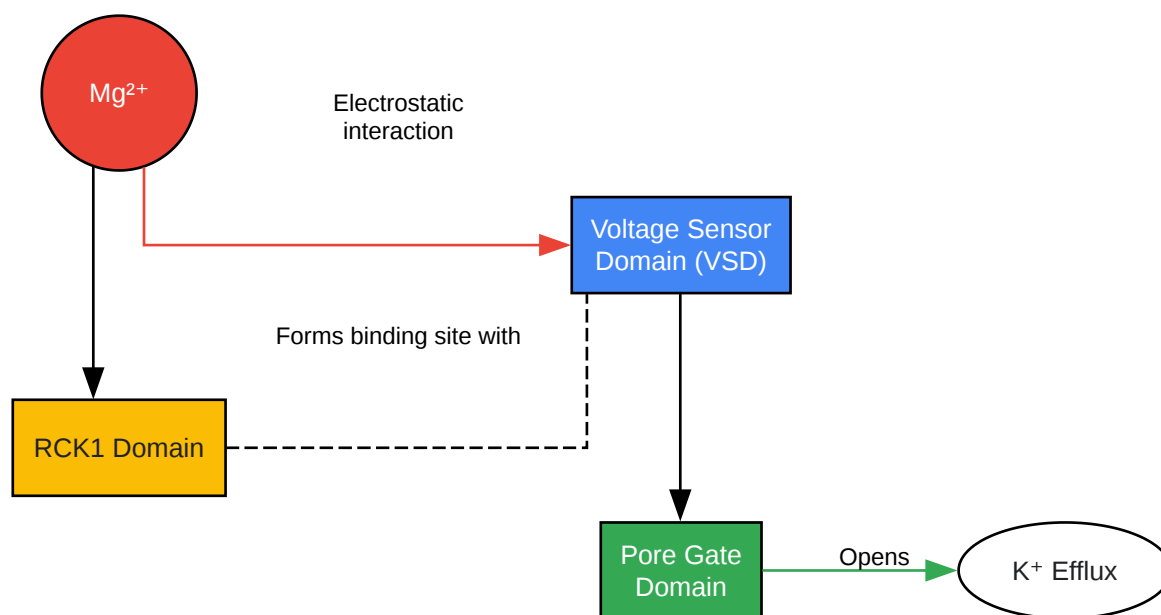

[Click to download full resolution via product page](#)

Caption: Signaling pathway of Mg<sup>2+</sup>-dependent BK channel activation.

Site-Directed Mutagenesis

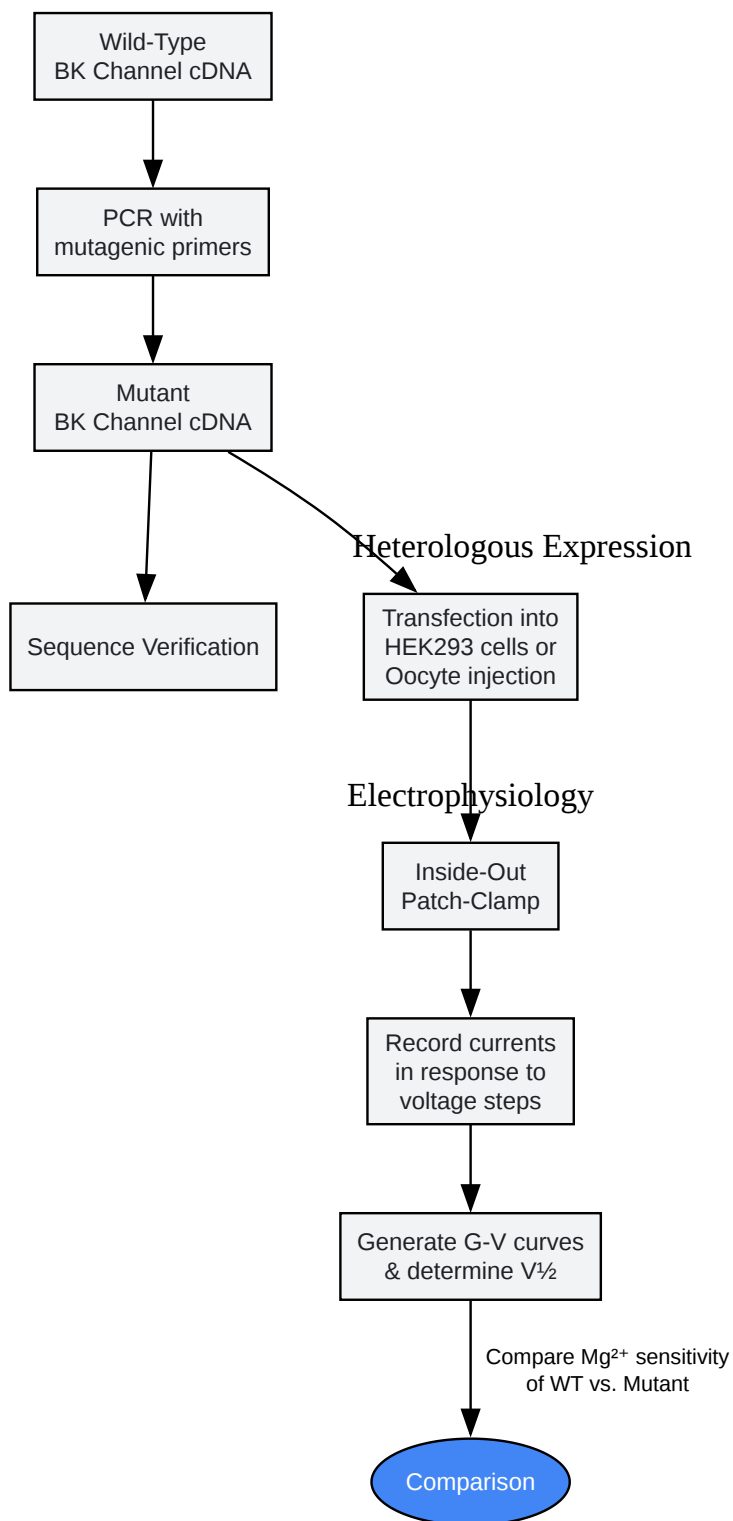

[Click to download full resolution via product page](#)

Caption: Experimental workflow for confirming the Mg<sup>2+</sup> binding site.

## Conclusion

The interaction between magnesium and the RCK domain of BK channels represents a sophisticated allosteric mechanism that is distinct from the canonical  $\text{Ca}^{2+}$ -dependent activation. A combination of electrophysiology, site-directed mutagenesis, and structural modeling has been essential in confirming this interaction and elucidating its functional consequences. Future research employing high-resolution structural techniques like cryo-EM in the presence of  $\text{Mg}^{2+}$  will be invaluable for visualizing the precise coordination of the ion and the resulting conformational changes in the channel. For drug development professionals, the unique nature of this  $\text{Mg}^{2+}$  binding site presents a potential target for the development of novel BK channel modulators with distinct mechanisms of action.

### Need Custom Synthesis?

BenchChem offers custom synthesis for rare earth carbides and specific isotopic labeling.

Email: [info@benchchem.com](mailto:info@benchchem.com) or [Request Quote Online](#).

## References

- [1. Activation of Slo1 BK channels by  \$\text{Mg}^{2+}\$  coordinated between the voltage sensor and the RCK1 domains - PMC \[pmc.ncbi.nlm.nih.gov\]](#)
- [2. Frontiers | BK Channel Gating Mechanisms: Progresses Toward a Better Understanding of Variants Linked Neurological Diseases \[frontiersin.org\]](#)
- [3. research.engineering.wustl.edu \[research.engineering.wustl.edu\]](#)
- [4. Mechanism of magnesium activation of calcium-activated potassium channels - PubMed \[pubmed.ncbi.nlm.nih.gov\]](#)
- [5. BK channel - Wikipedia \[en.wikipedia.org\]](#)
- [6. Structural Basis for Calcium and Magnesium Regulation of a Large Conductance Calcium-activated Potassium Channel with  \$\beta 1\$  Subunits - PMC \[pmc.ncbi.nlm.nih.gov\]](#)
- [7. Interaction between residues in the  \$\text{Mg}^{2+}\$ -binding site regulates BK channel activation - PubMed \[pubmed.ncbi.nlm.nih.gov\]](#)
- [8.  \$\text{Mg}^{2+}\$  enhances voltage sensor/gate coupling in BK channels - PubMed \[pubmed.ncbi.nlm.nih.gov\]](#)
- [9. researchgate.net \[researchgate.net\]](#)

- [10. Tuning magnesium sensitivity of BK channels by mutations - PubMed \[pubmed.ncbi.nlm.nih.gov\]](#)
- [11. Structure of the RCK domain from the E. coli K+ channel and demonstration of its presence in the human BK channel - PubMed \[pubmed.ncbi.nlm.nih.gov\]](#)
- [12. ks.uiuc.edu \[ks.uiuc.edu\]](#)
- [13. BK channel activation: structural and functional insights - PMC \[pmc.ncbi.nlm.nih.gov\]](#)
- [14. Voltage-dependent dynamics of the BK channel cytosolic gating ring are coupled to the membrane-embedded voltage sensor | eLife \[elifesciences.org\]](#)
- [15. The Contribution of RCK Domains to Human BK Channel Allosteric Activation\\* | Semantic Scholar \[semanticscholar.org\]](#)
- [16. pnas.org \[pnas.org\]](#)
- To cite this document: BenchChem. [Decoding the Magnesium-RCK Domain Interaction in BK Channels: A Comparative Guide]. BenchChem, [2026]. [Online PDF]. Available at: [<https://www.benchchem.com/product/b14494520/docs#decoding-the-magnesium-rck-domain-interaction-in-bk-channels-a-comparative-guide>]

---

#### Disclaimer & Data Validity:

The information provided in this document is for Research Use Only (RUO) and is strictly not intended for diagnostic or therapeutic procedures. While BenchChem strives to provide accurate protocols, we make no warranties, express or implied, regarding the fitness of this product for every specific experimental setup.

**Technical Support:** The protocols provided are for reference purposes. Unsure if this reagent suits your experiment?

**Need Industrial/Bulk Grade?** [Request Custom Synthesis Quote](#)

# BenchChem

Our mission is to be the trusted global source of essential and advanced chemicals, empowering scientists and researchers to drive progress in science and industry.

## Contact

Address: 3281 E Guasti Rd

Ontario, CA 91761, United States

Phone: (601) 213-4426

Email: [info@benchchem.com](mailto:info@benchchem.com)

[Contact our Ph.D. Support Team for a compatibility check](#)