

A Comparative Analysis of Magnesium and Spermine Blockade of Inward Rectifier K⁺ Channels

Author: BenchChem Technical Support Team. **Date:** May 2026

Compound of Interest

Compound Name: Magnesium;potassium

CAS No.: 65380-44-1

Cat. No.: B14494520

[Get Quote](#)

A comprehensive guide for researchers and drug development professionals on the differential blockade of inward rectifier potassium (Kir) channels by magnesium (Mg²⁺) and spermine.

In the realm of cellular electrophysiology, the precise regulation of ion channel activity is paramount for maintaining cellular excitability and function. Inward rectifier potassium (Kir) channels play a crucial role in these processes by allowing a larger influx of potassium (K⁺) ions into the cell than the outward efflux, a property known as inward rectification. This unique characteristic is not intrinsic to the channel itself but is conferred by the voltage-dependent blockade of the channel pore by intracellular cations, most notably magnesium (Mg²⁺) and the polyamine spermine. Understanding the distinct mechanisms and quantitative differences in how these two molecules modulate Kir channel function is essential for both basic research and the development of novel therapeutics targeting these channels.

This guide provides a detailed comparative analysis of Mg²⁺ and spermine as blockers of Kir channels, supported by experimental data and methodologies.

Differentiating Blockade: Magnesium vs. Spermine

While both Mg^{2+} and spermine contribute to the inward rectification of Kir channels, they do so through distinct mechanisms and with differing potencies and kinetics.^{[1][2]} Intracellular Mg^{2+} blocks the outward flow of K^+ ions in a voltage-dependent manner that is virtually time-independent.^{[1][2]} This blockade often results in a decrease in the unitary current amplitude by inducing subconducting states.^{[1][2]}

In contrast, spermine, a polyamine, blocks outward Kir currents in a manner that is dependent on both voltage and time.^{[1][2]} Unlike Mg^{2+} , spermine typically reduces the channel's open probability without affecting the unitary current amplitude.^{[1][2]} The voltage dependence of the spermine block is also steeper than that observed with Mg^{2+} .^{[1][2]}

Interestingly, when both blockers are present, a competitive interaction is observed.^{[1][2]} Mg^{2+} can attenuate the inhibitory effect of spermine on outward currents, a phenomenon that is also voltage and time-dependent.^{[1][2]} This suggests that Mg^{2+} and spermine may bind competitively within the channel pore.^{[1][2]} Some studies propose a synergistic blocking effect, where the lower-affinity Mg^{2+} may prevent the outward exit of the higher-affinity spermine, particularly during strong membrane depolarization.^[3]

Quantitative Comparison of Blocker Efficacy

The following table summarizes key quantitative parameters for the blockade of Kir channels by Mg^{2+} and spermine, compiled from various experimental studies. These values highlight the significantly higher affinity of spermine for Kir channels compared to Mg^{2+} .

Blocker	Channel Subtype	Apparent Affinity (Kd or IC50)	Key Characteristics
Magnesium (Mg ²⁺)	Kir2.1	mM range	Voltage-dependent, time-independent block; induces subconducting states. [1][2]
Kir2.2	μM to mM range	-	
Spermine	Kir2.1	nM to μM range	Steeply voltage-dependent and time-dependent block; reduces open probability. [1][2][4]
Kir2.2	nM range	-	
Kir3.1/3.4	-	Weaker inward rectification compared to Kir2.1, suggesting a different balance of polyamine block and permeation. [5]	

Experimental Methodologies

The investigation of Mg²⁺ and spermine block of Kir channels predominantly relies on the inside-out patch-clamp electrophysiology technique. [6] This powerful method allows for the direct application of known concentrations of blockers to the intracellular face of the cell membrane, enabling precise characterization of their effects on channel activity.

General Experimental Protocol:

- **Cell Preparation and Channel Expression:** A suitable cell line, such as Human Embryonic Kidney (HEK) 293 cells or *Xenopus* oocytes, is transfected with the cDNA encoding the specific Kir channel subtype of interest (e.g., Kir2.1). [1][2][7]

- Patch-Clamp Recording:
 - A glass micropipette with a small tip diameter is used to form a high-resistance "giga-ohm" seal with the cell membrane.
 - The pipette is then retracted to excise a small patch of the membrane, with the intracellular side facing the bath solution (inside-out configuration).[6]
- Solution Exchange: The excised patch is perfused with a series of intracellular solutions. Initially, a control solution without Mg²⁺ or spermine is used to measure the unblocked channel activity. Subsequently, solutions containing varying concentrations of Mg²⁺ or spermine are applied to the patch.[6]
- Voltage Protocols: A series of voltage steps or ramps are applied across the membrane patch to elicit and measure both inward and outward K⁺ currents. This allows for the determination of the voltage-dependence of the block.
- Data Analysis: The recorded currents are analyzed to determine parameters such as the half-maximal inhibitory concentration (IC₅₀), the dissociation constant (K_d), and the voltage at which half of the channels are blocked (V_{1/2}).

Representative Solutions:

- Pipette (Extracellular) Solution (in mM): 140 KCl, 1 CaCl₂, 1 MgCl₂, 10 HEPES; adjusted to pH 7.4 with KOH.
- Bath (Intracellular) Solution (in mM): 140 KCl, 2 MgCl₂, 5 EGTA, 10 HEPES; adjusted to pH 7.4 with KOH. Stock solutions of MgCl₂ and spermine tetrachloride are added to the bath solution to achieve the desired final concentrations.

Visualizing the Mechanisms and Workflows

To better understand the concepts discussed, the following diagrams illustrate the proposed blocking mechanisms and the experimental workflow.

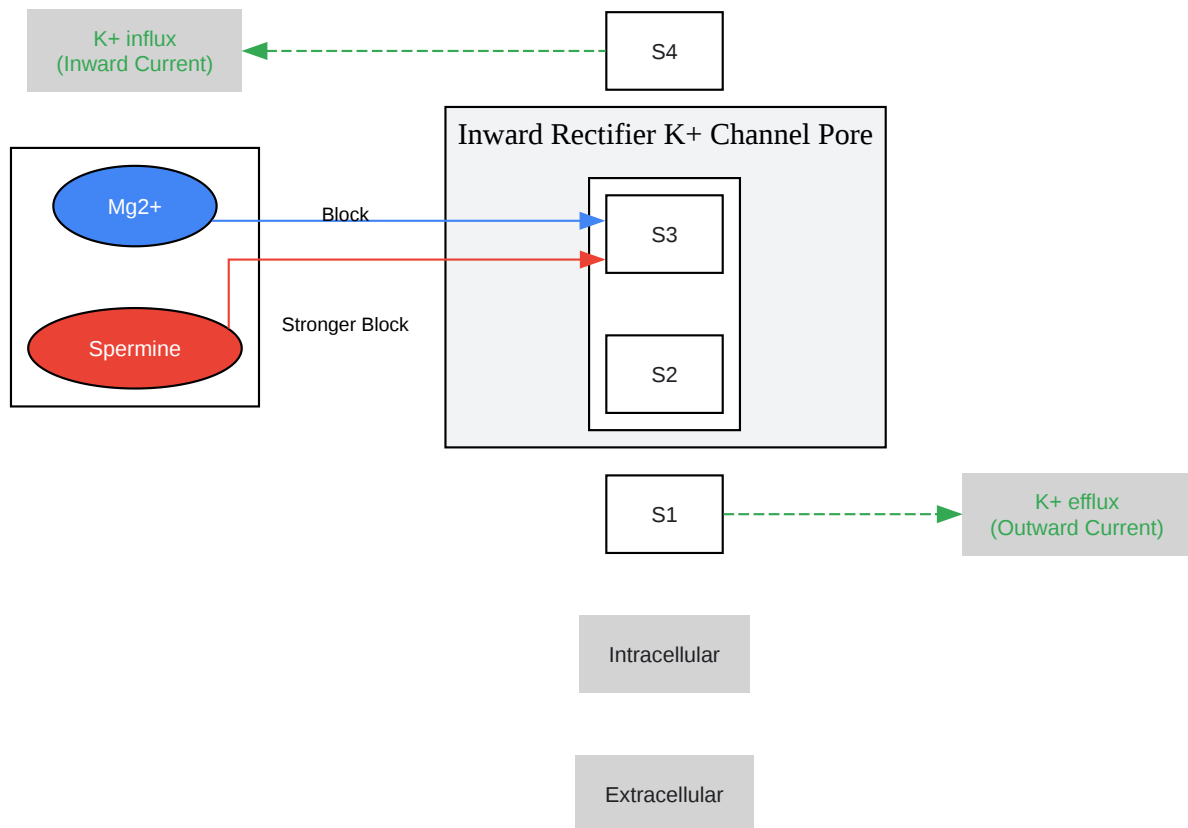

[Click to download full resolution via product page](#)

Caption: Mechanism of Kir channel blockade by Mg²⁺ and spermine.

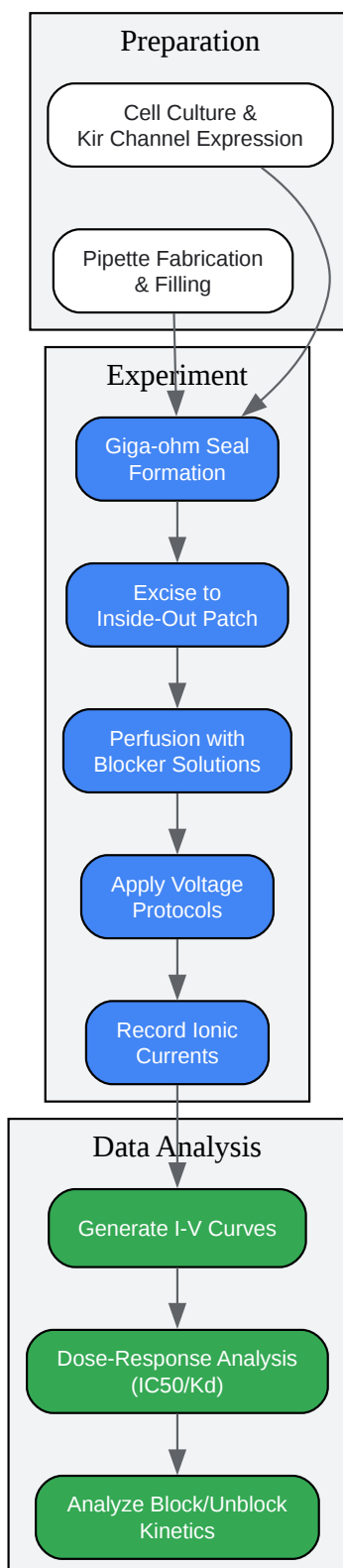

[Click to download full resolution via product page](#)

Caption: Experimental workflow for studying Kir channel blockers.

Conclusion

The blockade of inward rectifier K⁺ channels by intracellular Mg²⁺ and spermine is a fundamental mechanism governing cellular excitability. While both cations contribute to inward rectification, they exhibit distinct blocking characteristics. Spermine demonstrates a much higher affinity and a more complex, time-dependent blocking mechanism compared to the relatively simpler, time-independent block by Mg²⁺. A thorough understanding of these differences, gained through meticulous experimental techniques like inside-out patch-clamping, is critical for elucidating the physiological roles of Kir channels and for the rational design of drugs targeting these important ion channels. The competitive and potentially synergistic nature of their interaction adds another layer of complexity that warrants further investigation.

Need Custom Synthesis?

BenchChem offers custom synthesis for rare earth carbides and specific isotopic labeling.

Email: info@benchchem.com or [Request Quote Online](#).

References

- 1. Competition between Mg²⁺ and spermine for a cloned IRK2 channel expressed in a human cell line - PMC [[pmc.ncbi.nlm.nih.gov](https://pubmed.ncbi.nlm.nih.gov/)]
- 2. Competition between Mg²⁺ and spermine for a cloned IRK2 channel expressed in a human cell line - PubMed [pubmed.ncbi.nlm.nih.gov]
- 3. A synergistic blocking effect of Mg²⁺ and spermine on the inward rectifier K⁺ (Kir2.1) channel pore - PubMed [pubmed.ncbi.nlm.nih.gov]
- 4. Voltage-dependent gating and block by internal spermine of the murine inwardly rectifying K⁺ channel, Kir2.1 - PMC [[pmc.ncbi.nlm.nih.gov](https://pubmed.ncbi.nlm.nih.gov/)]
- 5. A difference in inward rectification and polyamine block and permeation between the Kir2.1 and Kir3.1/Kir3.4 K⁺ channels - PMC [[pmc.ncbi.nlm.nih.gov](https://pubmed.ncbi.nlm.nih.gov/)]
- 6. Polyamine Block of Inwardly Rectifying Potassium Channels - PMC [[pmc.ncbi.nlm.nih.gov](https://pubmed.ncbi.nlm.nih.gov/)]
- 7. Spermine Block of the Strong Inward Rectifier Potassium Channel Kir2.1: Dual Roles of Surface Charge Screening and Pore Block - PMC [[pmc.ncbi.nlm.nih.gov](https://pubmed.ncbi.nlm.nih.gov/)]
- To cite this document: BenchChem. [A Comparative Analysis of Magnesium and Spermine Blockade of Inward Rectifier K⁺ Channels]. BenchChem, [2026]. [Online PDF]. Available at:

[<https://www.benchchem.com/product/b14494520/docs#a-comparative-analysis-of-magnesium-and-spermine-blockade-of-inward-rectifier-k-channels>]

Disclaimer & Data Validity:

The information provided in this document is for Research Use Only (RUO) and is strictly not intended for diagnostic or therapeutic procedures. While BenchChem strives to provide accurate protocols, we make no warranties, express or implied, regarding the fitness of this product for every specific experimental setup.

Technical Support: The protocols provided are for reference purposes. Unsure if this reagent suits your experiment?

Need Industrial/Bulk Grade? [Request Custom Synthesis Quote](#)

BenchChem

Our mission is to be the trusted global source of essential and advanced chemicals, empowering scientists and researchers to drive progress in science and industry.

Contact

Address: 3281 E Guasti Rd
Ontario, CA 91761, United States
Phone: (601) 213-4426
Email: info@benchchem.com

[Contact our Ph.D. Support Team for a compatibility check](#)