

Technical Support Center: Solvent Effects on Pyrazole Formation Regioselectivity

Author: BenchChem Technical Support Team. **Date:** May 2026

Compound of Interest

Compound Name: 5-fluoro-1-phenyl-1H-pyrazole

CAS No.: 1781334-23-3

Cat. No.: B1449039

[Get Quote](#)

Welcome to the technical support center for controlling regioselectivity in pyrazole synthesis. This guide is designed for researchers, medicinal chemists, and process development scientists who encounter challenges with isomeric purity during the synthesis of substituted pyrazoles. We will explore the mechanistic underpinnings of how solvents dictate reaction outcomes and provide practical, field-tested protocols to overcome common experimental hurdles.

Frequently Asked Questions (FAQs)

Q1: What exactly is regioselectivity in the context of pyrazole synthesis, and why is it a critical issue?

A: Regioselectivity refers to the preference for forming one constitutional isomer over other possibilities in a chemical reaction.^[1] In pyrazole synthesis, this issue most commonly arises when reacting an unsymmetrical 1,3-dicarbonyl compound with a substituted hydrazine (like methylhydrazine).^{[1][2]} The hydrazine has two distinct nitrogen atoms that can initiate the reaction, and the dicarbonyl has two different carbonyl carbons that can be attacked. This leads to two possible reaction pathways, potentially forming a mixture of two regioisomeric pyrazoles.

Controlling this selectivity is crucial because different regioisomers often possess vastly different pharmacological, toxicological, and physical properties.[3] For drug development and agrochemical applications, synthesizing the desired, biologically active isomer in high purity is essential for efficacy and regulatory approval. Poor regioselectivity leads to difficult and costly separation processes, reducing the overall yield of the target molecule.[3]

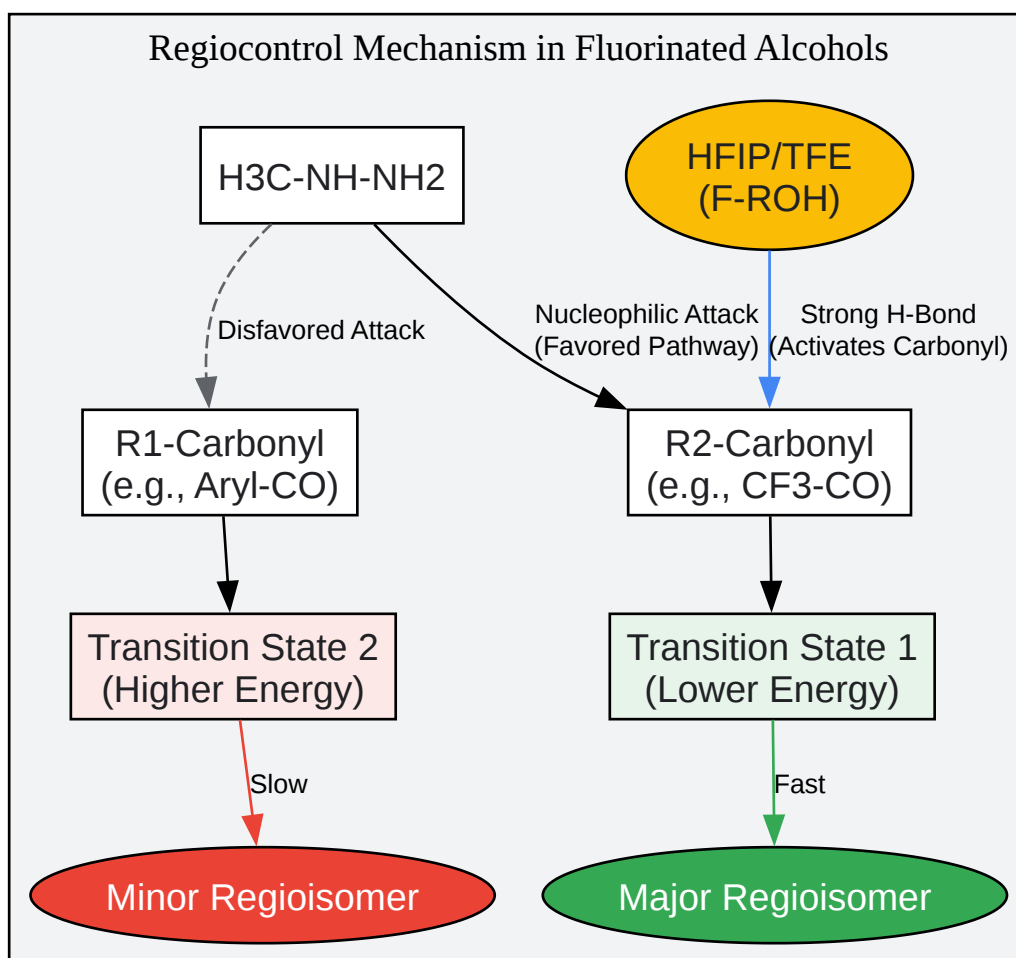
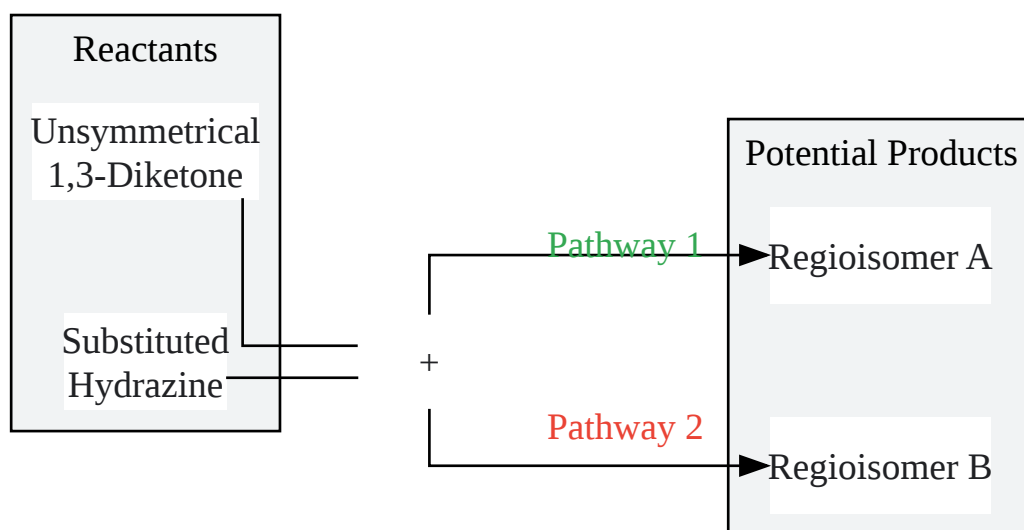

[Click to download full resolution via product page](#)

Caption: Solvent-mediated activation dictates the favored reaction pathway.

Troubleshooting & Optimization Guide

Issue: My reaction produces a mixture of regioisomers, even after switching to a fluorinated solvent.

This can be a frustrating issue, but it indicates that factors beyond simple solvent choice are at play. Here is a checklist of potential causes and solutions to systematically troubleshoot your experiment.

Potential Cause	Explanation & Causality	Recommended Solution(s)
1. Insufficient Electronic/Steric Bias	If the two substituents on your 1,3-dicarbonyl are very similar in size and electronic nature, even a powerful solvent like HFIP may not be able to induce high selectivity. The activation energy difference between the two pathways remains too small.	Modify the Substrate: If possible, redesign the dicarbonyl precursor to have more distinct electronic or steric features. Change Synthetic Strategy: Instead of a 1,3-diketone, consider using a β -enaminone or an α,β -unsaturated ketone, which pre-determines the site of initial attack. [1]
2. Reaction Temperature	Higher temperatures provide more energy to the system, which can allow the reaction to overcome the activation barrier for the less-favored pathway, leading to a decrease in selectivity.	Lower the Temperature: Run the reaction at room temperature or even 0 °C. Many reactions in TFE or HFIP proceed efficiently without heating. Monitor progress by TLC to determine the optimal time.
3. pH Effects	The reaction mechanism is pH-sensitive. Under strongly acidic conditions, both nitrogens of the hydrazine can be protonated, altering their nucleophilicity and potentially changing the reaction outcome. While fluorinated alcohols are acidic, they typically do not require an additional acid catalyst.	Avoid Acid Catalysts: Unless a specific protocol requires it, do not add strong acids like HCl or H ₂ SO ₄ when using TFE or HFIP. The solvent itself provides the necessary activation. [3]
4. Solvent Purity & Water Content	Water can compete with the fluorinated alcohol as a hydrogen-bonding species and may alter the solvation sphere	Use Anhydrous Solvent: Ensure your fluorinated alcohol is dry. Use a freshly opened

around the reactants,
potentially diminishing the
directing effect of the solvent.

bottle or dry it over molecular
sieves if necessary.

Data Summary: Solvent Impact on Regioisomeric Ratio

The following table summarizes experimental data from the literature, clearly demonstrating the dramatic effect of solvent choice on the reaction between an unsymmetrical fluorinated 1,3-diketone and methylhydrazine. [3]

Entry	Solvent	Temperature (°C)	Time (h)	Regioisomeric Ratio (Desired : Undesired)
1	Ethanol	Reflux	1	1 : 1.5
2	Ethanol	Room Temp.	24	1 : 1.2
3	TFE	Room Temp.	4	2.3 : 1

| 4 | HFIP | Room Temp. | 1 | >20 : 1 |

Data adapted from J. Org. Chem. 2008, 73, 20, 7857–7860. [3] As shown, switching from ethanol to HFIP (Entry 4) completely reverses and dramatically improves the regioselectivity, yielding almost exclusively the desired isomer in a short amount of time. [3][5]

Experimental Protocols

Protocol 1: High-Regioselectivity Synthesis in HFIP

[1] This protocol is optimized for achieving high regioselectivity in the synthesis of N-methylpyrazoles from unsymmetrical 1,3-diketones.

Materials:

- Unsymmetrical 1,3-diketone (1.0 mmol, 1.0 eq)
- Methylhydrazine (1.1 mmol, 1.1 eq)
- 1,1,1,3,3,3-Hexafluoro-2-propanol (HFIP), anhydrous (3-5 mL)
- Round-bottom flask with magnetic stir bar
- Standard workup and purification supplies (rotary evaporator, silica gel, solvents for chromatography)

Procedure:

- Setup: In a clean, dry round-bottom flask equipped with a magnetic stir bar, dissolve the 1,3-diketone (1.0 mmol) in anhydrous HFIP (3 mL). Stir at room temperature until fully dissolved.
- Reagent Addition: To the stirring solution, add methylhydrazine (1.1 mmol) dropwise at room temperature.
- Reaction Monitoring: Stir the reaction mixture at room temperature. The reaction is often complete within 1-4 hours. [1] Monitor the consumption of the starting material by Thin Layer Chromatography (TLC) using an appropriate solvent system (e.g., 4:1 Hexane:Ethyl Acetate).
- Workup: Once the reaction is complete (as indicated by TLC), remove the HFIP solvent under reduced pressure using a rotary evaporator. Caution: HFIP is volatile and corrosive; ensure your vacuum setup is appropriate.
- Purification: Purify the resulting crude residue by flash column chromatography on silica gel. Elute with a suitable solvent gradient (e.g., starting with 9:1 Hexane:Ethyl Acetate) to separate the major regioisomer from any minor isomer and impurities.
- Characterization: Combine the fractions containing the pure product. Remove the solvent in vacuo. Characterize the final product and confirm its isomeric identity and purity using ^1H NMR, ^{13}C NMR, and GC-MS analysis.

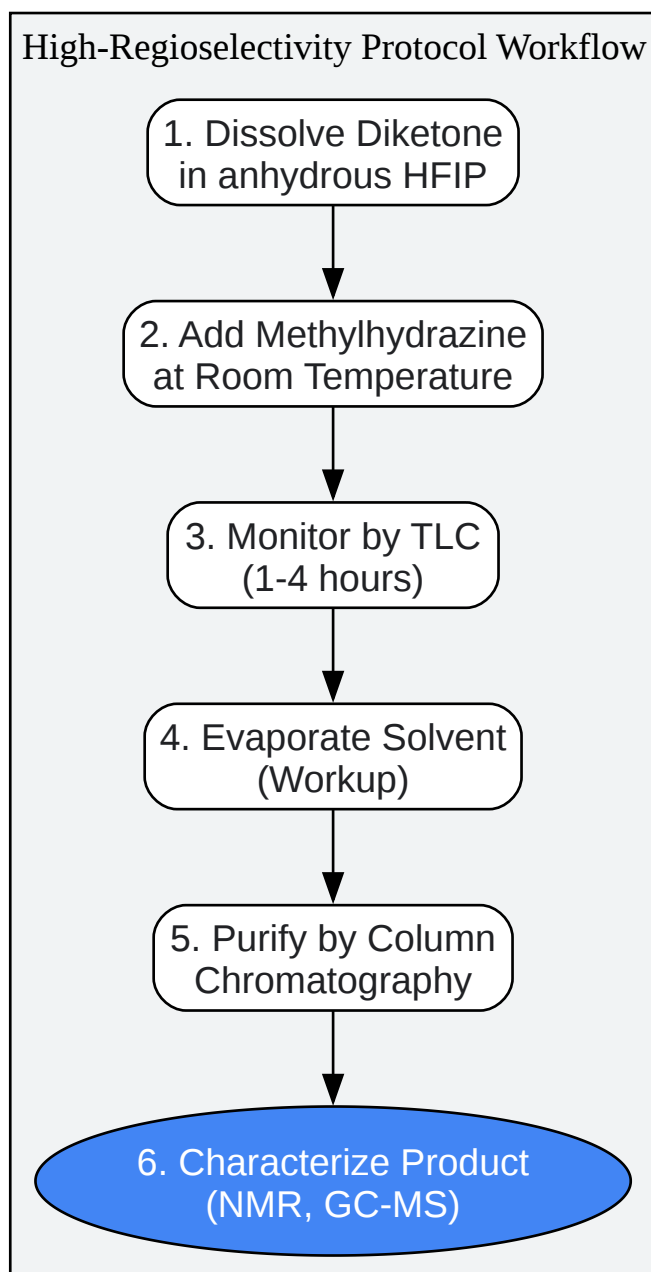

[Click to download full resolution via product page](#)

Caption: Step-by-step workflow for selective pyrazole synthesis.

References

- García-Lozano, M.; García-Álvarez, R.; El-SAYED, I.; Crochet, A.; Cadierno, V.; Borge, J.; Polo, V.; Sancho-García, J. C.; Soldevilla-Sanz, A.; Fustero, S. Improved Regioselectivity in Pyrazole Formation through the Use of Fluorinated Alcohols as Solvents: Synthesis and

Biological Activity of Fluorinated Tebufenpyrad Analogs. *The Journal of Organic Chemistry*, 2008, 73(19), 7857-7860. [\[Link\]](#)

- Fustero, S.; Sánchez-Roselló, M.; Soldevilla, A.; García-Lozano, M. Improved Regioselectivity in Pyrazole Formation through the Use of Fluorinated Alcohols as Solvents: Synthesis and Biological Ac. *The Journal of Organic Chemistry*, 2008. [\[Link\]](#)
- Yadav, V. Pyrazoles Syntheses, reactions and uses. YouTube, 2021. [\[Link\]](#)
- Owrang, F. Green synthesis of pyrazole systems under solvent-free conditions. Taylor & Francis Online, 2017. [\[Link\]](#)
- Pautels, C.; Noti, C.; Knochel, P. Synthesis of Fully Substituted Pyrazoles via Regio- and Chemoselective Metalations. *Organic Letters*, 2017. [\[Link\]](#)
- Hickey, A. M.; Powner, M. W. Discovery of unexpectedly complex reaction pathways for the Knorr pyrazole synthesis via transient flow. RSC Publishing, 2022. [\[Link\]](#)
- Organic Chemistry Portal. Pyrazole synthesis. Organic Chemistry Portal. [\[Link\]](#)
- Sgambat, K.; Landi, G.; Aiello, F.; De Vita, D.; Cirilli, R.; Bagalà, M.; Corbo, F.; Franchini, C.; Giliberti, G.; Tortorella, P. Regioselective Synthesis, Structural Characterization, and Antiproliferative Activity of Novel Tetra-Substituted Phenylaminopyrazole Derivatives. PubMed Central, 2022. [\[Link\]](#)
- Ebenezer, O.; Krishna, P. G.; Solomon, K. A. Recent Advances in the Synthesis of Pyrazole Derivatives: A Review. MDPI, 2023. [\[Link\]](#)
- Rojas-Lechuga, M. J.; J-Cruz, C.; Hernández-Vázquez, E.; González-Zamora, E.; Delgado, F.; Tamariz, J. A regioselective synthesis of 3,4-diaryl-1H-pyrazoles through a 1,3-dipolar cycloaddition of tosylhydrazones and nitroalkenes. *Organic & Biomolecular Chemistry*, 2019. [\[Link\]](#)
- Singh, S.; Kumar, V. Recent advances in the multicomponent synthesis of pyrazoles. *Organic & Biomolecular Chemistry*, 2024. [\[Link\]](#)

- ResearchGate. Pyrazole formation: Examination of kinetics, substituent effects, and mechanistic pathways. ResearchGate, 2025. [[Link](#)]
- ResearchGate. Investigate Solute-Solvent Interaction at Different Concentrations and Different Temperature of Substituted Pyrazole Ligands. ResearchGate, 2025. [[Link](#)]

Need Custom Synthesis?

BenchChem offers custom synthesis for rare earth carbides and specific isotopic labeling.

Email: info@benchchem.com or [Request Quote Online](#).

Sources

- 1. pdf.benchchem.com [pdf.benchchem.com]
- 2. Recent Advances in the Synthesis of Pyrazole Derivatives: A Review | MDPI [[mdpi.com](https://www.mdpi.com)]
- 3. pubs.acs.org [pubs.acs.org]
- To cite this document: BenchChem. [Technical Support Center: Solvent Effects on Pyrazole Formation Regioselectivity]. BenchChem, [2026]. [Online PDF]. Available at: [<https://www.benchchem.com/product/b1449039/docs#technical-support-center-solvent-effects-on-pyrazole-formation-regioselectivity>]

Disclaimer & Data Validity:

The information provided in this document is for Research Use Only (RUO) and is strictly not intended for diagnostic or therapeutic procedures. While BenchChem strives to provide accurate protocols, we make no warranties, express or implied, regarding the fitness of this product for every specific experimental setup.

Technical Support: The protocols provided are for reference purposes. Unsure if this reagent suits your experiment?

Need Industrial/Bulk Grade? [Request Custom Synthesis Quote](#)

BenchChem

Our mission is to be the trusted global source of essential and advanced chemicals, empowering scientists and researchers to drive progress in science and industry.

Contact

Address: 3281 E Guasti Rd

Ontario, CA 91761, United States

Phone: (601) 213-4426

Email: info@benchchem.com

[Contact our Ph.D. Support Team for a compatibility check](#)