

Technical Support Center: Optimizing Tetrahydropyridopyrimidine Synthesis

Author: BenchChem Technical Support Team. **Date:** May 2026

Compound of Interest

Compound Name: 5,6,7,8-Tetrahydropyrido[4,3-
d]pyrimidine oxalate

CAS No.: 1448137-78-7

Cat. No.: B1449735

[Get Quote](#)

Welcome to the technical support center for the synthesis of tetrahydropyridopyrimidines. This guide is designed for researchers, scientists, and professionals in drug development who are working with this important heterocyclic scaffold. Here, we will address common challenges encountered during synthesis and provide in-depth, field-tested solutions to optimize your reaction conditions.

The synthesis of tetrahydropyridopyrimidines, often achieved through multicomponent reactions like the Biginelli reaction or its variations, is a powerful tool in medicinal chemistry.[1] [2] However, like any complex organic synthesis, it can present challenges ranging from low yields to difficult purifications. This guide is structured in a question-and-answer format to directly address the specific issues you may be facing in the lab.

Troubleshooting Guide: Common Issues and Solutions

Q1: My tetrahydropyridopyrimidine synthesis is resulting in very low yields. What are the common causes and how can I improve it?

Low yield is one of the most frequent frustrations in organic synthesis. For tetrahydropyridopyrimidine synthesis, several factors can be at play. Let's break down the potential causes and solutions.

Potential Causes & Optimization Strategies:

- **Suboptimal Catalyst:** The choice and concentration of the catalyst are critical. While classic Biginelli reactions use strong Brønsted acids like HCl, these can sometimes promote side reactions.^[3]
 - **Solution:** Screen a variety of catalysts. Lewis acids (e.g., La(OTf)₃, ZrO₂ nanoparticles) or milder Brønsted acids (e.g., p-toluenesulfonic acid) can be highly effective.^{[4][5][6]} In some cases, organocatalysts can also offer excellent results.^[7] Start with a catalyst loading of 10-20 mol% and optimize from there. The absence of a catalyst often leads to poor yields.^[3]
- **Inefficient Reaction Conditions:** Temperature and reaction time are key parameters that need to be finely tuned.
 - **Solution:** Monitor your reaction progress meticulously using Thin Layer Chromatography (TLC). This will help you determine the optimal reaction time and prevent product degradation from prolonged heating.^[8] While refluxing in a solvent like ethanol is a common starting point, some substrate combinations may benefit from lower temperatures over a longer period, or even solvent-free conditions.^{[4][8]}
- **Poor Reactant Purity:** Impurities in your starting materials (aldehyde, β-dicarbonyl compound, and urea/thiourea derivative) can significantly inhibit the reaction.
 - **Solution:** Ensure all reactants are of high purity. If necessary, purify your starting materials before use. For example, aldehydes can be prone to oxidation, so using a freshly opened bottle or distilling the aldehyde can make a substantial difference.

- Solvent Effects: The polarity and solubilizing power of the solvent can dramatically impact the reaction rate and final yield.
 - Solution: If your yield is low in a standard solvent like ethanol, consider exploring other options. Acetonitrile, dioxane, or solvent mixtures can sometimes provide superior results. [1][4] For substrates with poor solubility, a solvent system that can fully dissolve all reactants at the reaction temperature is crucial.

Parameter	Starting Point	Optimization Strategy
Catalyst	10 mol% p-TSA or HCl in Ethanol	Screen Lewis acids (e.g., La(OTf) ₃ , ZrO ₂) and vary loading (5-30 mol%).
Temperature	Reflux in Ethanol (~78 °C)	Test a range from room temperature to 120 °C (if using a higher boiling solvent).
Solvent	Ethanol	Trial other solvents like acetonitrile, DMF, or solvent-free conditions.
Reaction Time	12-24 hours	Monitor by TLC to determine the point of maximum product formation.

Q2: I am observing a significant amount of an unexpected side product. How can I identify and minimize its formation?

The formation of side products is a common hurdle, complicating purification and reducing the yield of the desired tetrahydropyridopyrimidine.

Common Side Products and Mitigation Strategies:

- Hantzsch-type 1,4-Dihydropyridines: This is a frequent byproduct, especially when using urea at higher temperatures. It arises from a competing reaction where two equivalents of

the β -ketoester react with the aldehyde.[8]

- Identification: This byproduct is often fluorescent and can be identified by mass spectrometry and NMR.
- Solution: Lowering the reaction temperature can significantly suppress the Hantzsch pathway.[8] The choice of catalyst can also influence the selectivity between the Biginelli and Hantzsch reactions.
- Oxidized Pyridopyrimidine Derivatives: The tetrahydropyridopyrimidine ring can sometimes be susceptible to oxidation, leading to the formation of the corresponding aromatic pyridopyrimidine.
 - Identification: A change in the product's solubility and a downfield shift of the protons on the newly formed aromatic ring in the ^1H NMR spectrum are indicative of this side product.
 - Solution: Running the reaction under an inert atmosphere (e.g., nitrogen or argon) can help to minimize oxidation. Additionally, avoid overly harsh reaction conditions or prolonged reaction times at high temperatures.
- N-Acylurea Byproducts: These can form from the reaction of the β -ketoester with urea, creating a purification challenge.[8]
 - Identification: These byproducts can be identified by their characteristic signals in ^1H and ^{13}C NMR spectroscopy and by mass spectrometry.
 - Solution: Careful control of the reaction stoichiometry and catalyst can sometimes suppress the formation of N-acylureas. For purification, recrystallization is often the most effective method for removing these impurities.[8]

Q3: The purification of my crude tetrahydropyridopyrimidine product is difficult. What are the best strategies?

The polarity and sometimes poor solubility of tetrahydropyridopyrimidines can make their purification challenging.

Recommended Purification Techniques:

- **Recrystallization:** This is often the most effective method for purifying tetrahydropyridopyrimidines, especially for removing closely related impurities.
 - **Protocol:**
 - Dissolve the crude product in a minimum amount of a suitable hot solvent (e.g., ethanol, isopropanol, or a mixture like ethanol/water).
 - If the solution is colored, you can add a small amount of activated charcoal and heat for a short period.
 - Hot filter the solution to remove any insoluble impurities.
 - Allow the solution to cool slowly to room temperature, and then in an ice bath to maximize crystal formation.
 - Collect the crystals by filtration, wash with a small amount of cold solvent, and dry under vacuum.
- **Column Chromatography:** If recrystallization is not effective, flash column chromatography on silica gel is the next logical step.
 - **Pro-Tip:** Due to the polarity of many tetrahydropyridopyrimidines, a standard ethyl acetate/hexane solvent system may not be sufficient. Consider using a more polar mobile phase, such as dichloromethane/methanol or ethyl acetate/methanol. Adding a small amount of triethylamine (0.1-1%) to the eluent can help to reduce tailing of basic compounds on the silica gel.
- **Acid-Base Extraction:** If your product has a basic nitrogen atom, an acid-base extraction can be a useful preliminary purification step to remove non-basic impurities.
 - Dissolve the crude product in an organic solvent (e.g., dichloromethane or ethyl acetate).
 - Extract with a dilute aqueous acid solution (e.g., 1M HCl). The basic product will move to the aqueous layer.

- Wash the aqueous layer with an organic solvent to remove any remaining neutral or acidic impurities.
- Basify the aqueous layer with a base (e.g., 1M NaOH or saturated NaHCO₃) until the product precipitates or can be extracted back into an organic solvent.
- Dry the organic layer over an anhydrous salt (e.g., Na₂SO₄ or MgSO₄), filter, and concentrate to obtain the purified product.

Frequently Asked Questions (FAQs)

Q: What is the general mechanism for the acid-catalyzed synthesis of tetrahydropyridopyrimidines via the Biginelli reaction?

A: The Biginelli reaction proceeds through a series of acid-catalyzed steps. First, the aldehyde and urea condense to form an N-acyliminium ion intermediate. This is followed by the nucleophilic addition of the enol form of the β-dicarbonyl compound. The final step is a cyclization and dehydration to yield the tetrahydropyridopyrimidine core.

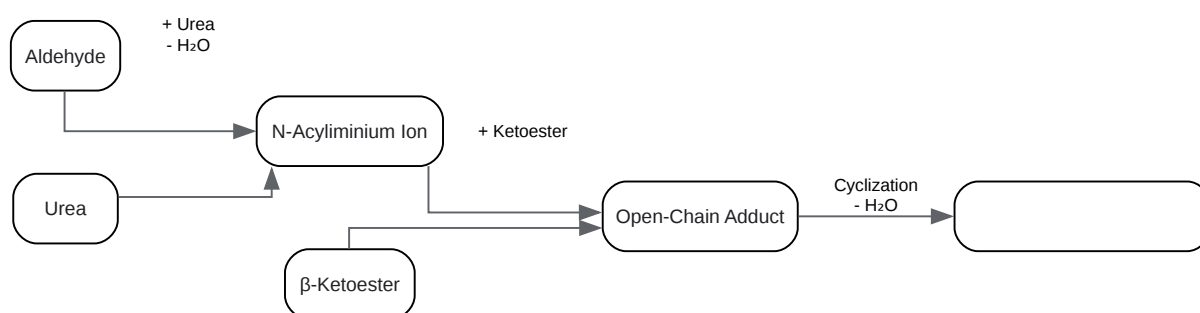

[Click to download full resolution via product page](#)

Caption: Simplified mechanism of the Biginelli reaction.

Q: Can I use thiourea instead of urea in this reaction?

A: Yes, thiourea and its derivatives are commonly used in Biginelli-type reactions to synthesize the corresponding thioxo-tetrahydropyrimidines.[9] These sulfur-containing analogs are also of

significant interest in medicinal chemistry. The reaction conditions are generally similar to those used with urea, although in some cases, the use of thioureas can be challenging under heating.[1]

Q: How can I introduce diversity into the tetrahydropyridopyrimidine scaffold?

A: The multicomponent nature of the synthesis is ideal for creating a library of diverse compounds.[2] You can vary each of the three core components:

- The Aldehyde: A wide range of aromatic, heteroaromatic, and aliphatic aldehydes can be used.
- The β -Dicarbonyl Compound: Besides simple acetoacetates, you can use other 1,3-dicarbonyl compounds, such as acetylacetone or ethyl benzoylacetate, to modify the substitution pattern on the pyrimidine ring.
- The Urea/Thiourea Component: N-substituted ureas and thioureas can be employed to introduce substituents at the N1 and/or N3 positions of the ring.

Q: Are there any green or more sustainable methods for this synthesis?

A: Absolutely. There is a growing emphasis on developing more environmentally friendly synthetic methods. For tetrahydropyridopyrimidine synthesis, this includes:

- Solvent-free reactions: Heating the neat reactants with a catalyst can be very efficient and eliminates the need for organic solvents.[5]
- Use of heterogeneous catalysts: Nanocatalysts, such as magnetic nanoparticles, can be easily recovered and reused, reducing waste.[5][9]
- Microwave-assisted synthesis: Microwave irradiation can often significantly reduce reaction times and improve yields.

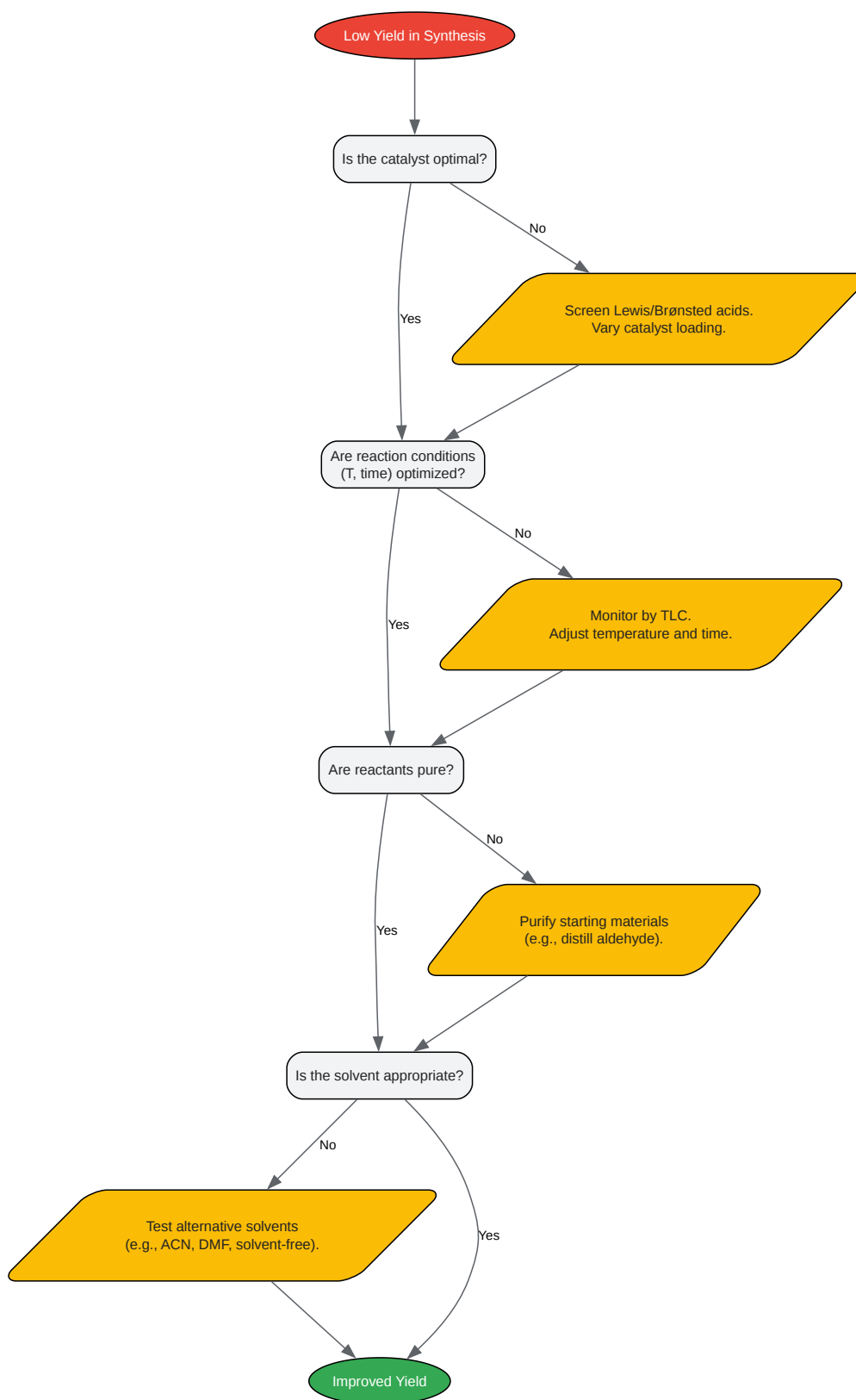

[Click to download full resolution via product page](#)

Caption: Decision workflow for troubleshooting low yields.

References

- Stadler, A., & Kappe, C. O. (2001). The Biginelli Dihydropyrimidine Synthesis. In *Modern Multicomponent Reactions* (pp. 1-36). Wiley-VCH Verlag GmbH & Co. KGaA.
- Kappe, C. O. (2000). Recent advances in the Biginelli dihydropyrimidine synthesis. New tricks from an old dog. *Accounts of Chemical Research*, 33(12), 879-888.
- Proposed mechanism for the synthesis of tetrahydropyrido[2,3-d]pyrimidines. (n.d.). ResearchGate. Retrieved January 20, 2026, from [[Link](#)]
- Kumar, A., Singh, R., & Kumar, S. (2012). One-pot synthesis of tetrahydropyrimidinecarboxamides enabling in vitro anticancer activity: a combinative study with clinically relevant brain-penetrant drugs. *RSC Advances*, 2(27), 10243-10251.
- Abdolmohammadi, S., & Balalaie, S. (2012). Zirconium dioxide nanoparticles as a useful heterogeneous nano-catalyst in a green procedure for the synthesis of tetrahydropyrido[2,3-d]pyrimidines integrated enamionitrile motif.
- Fathalla, W., et al. (2021). Design, synthesis and evaluation of novel tetrahydropyridothienopyrimidin-ureas as cytotoxic and anti-angiogenic agents. *Scientific Reports*, 11(1), 1-16.
- Asgari, M. S., et al. (2024). Cu@DPP-SPION: A Novel and Versatile Catalyst for the Synthesis of Thioxo-Tetrahydropyrimidine Derivatives under Mild Reaction Conditions. *Letters in Organic Chemistry*, 21(1), 1-10.
- Darakshan, S., & Parvin, T. (2022). Tetrahydropyridines: a recent update for their multicomponent synthesis. *RSC Advances*, 12(45), 29337-29367.
- Wang, L., et al. (2010). Primary Amine-Catalyzed Biginelli Reaction for the Enantioselective Synthesis of 3,4-Dihydropyrimidin-2(1H)-ones. *Organic Letters*, 12(24), 5684-5687.
- Janes, M. R., et al. (2018). Discovery of Tetrahydropyridopyrimidines as Irreversible Covalent Inhibitors of KRAS-G12C with In Vivo Activity. *ACS Medicinal Chemistry Letters*, 9(12), 1234-1239.
- Vasilenko, S. V., et al. (2019). A Four Component Biginelli's Reaction, New Opportunities for Synthesis of Functionalized Pyrimidines. *Biomedical Journal of Scientific & Technical Research*, 14(4).
- Vasilenko, S. V., et al. (2019). A Four Component Biginelli's Reaction, New Opportunities for Synthesis of Functionalized Pyrimidines. *Biomedical Journal of Scientific & Technical Research*, 14(4).
- Kappe, C. O. (2000). Recent advances in the Biginelli dihydropyrimidine synthesis. New tricks from an old dog. *Accounts of Chemical Research*, 33(12), 879-888.
- Wang, H., et al. (2023). Synthesis of Adagrasib (MRTX849), a Covalent KRASG12C Inhibitor Drug for the Treatment of Cancer. *Organic Letters*, 25(5), 824-828.

- Wang, H., et al. (2023). Synthesis of Adagrasib (MRTX849), a Covalent KRASG12C Inhibitor Drug for the Treatment of Cancer. *Organic Letters*, 25(5), 824-828.
- Popa, M., & Finaru, A. L. (2022). Biginelli Reaction Mediated Synthesis of Antimicrobial Pyrimidine Derivatives and Their Therapeutic Properties. *Molecules*, 27(19), 6533.
- Janes, M. R., et al. (2018). Discovery of Tetrahydropyridopyrimidines as Irreversible Covalent Inhibitors of KRAS-G12C with In Vivo Activity. *ACS Medicinal Chemistry Letters*, 9(12), 1234-1239.
- Li, Y., et al. (2023). Design, Synthesis, Anticancer Evaluation and Molecular Docking of Pyrimidine, Pyrido[4,3-d]pyrimidine and 5,6,7,8-Tetrahydropyrido[3,4-d]pyrimidine Derivatives as Novel KRAS-G12D Inhibitors and PROTACs. *Pharmaceuticals*, 16(5), 696.
- Liu, G., et al. (2023). Design, Synthesis, and Structure–Activity Relationship of Tetrahydropyrido[4,3-d]pyrimidine Derivatives as Potent Smoothed Antagonists. *Journal of Medicinal Chemistry*, 66(8), 5549-5567.

Need Custom Synthesis?

BenchChem offers custom synthesis for rare earth carbides and specific isotopic labeling.

Email: info@benchchem.com or [Request Quote Online](#).

Sources

1. Synthesis, Characterization, and Biological Evaluation of Tetrahydropyrimidines: Dual-Activity and Mechanism of Action - PMC [[pmc.ncbi.nlm.nih.gov](https://pubmed.ncbi.nlm.nih.gov/)]
2. Tetrahydropyridines: a recent update for their multicomponent synthesis - RSC Advances (RSC Publishing) [pubs.rsc.org]
3. pdf.benchchem.com [pdf.benchchem.com]
4. One-pot synthesis of tetrahydropyrimidinecarboxamides enabling in vitro anticancer activity: a combinative study with clinically relevant brain-penetrant drugs - PMC [[pmc.ncbi.nlm.nih.gov](https://pubmed.ncbi.nlm.nih.gov/)]
5. Synthetic strategies of heterocycle-integrated pyridopyrimidine scaffolds supported by nano-catalysts - RSC Advances (RSC Publishing) DOI:10.1039/D3RA00922J [pubs.rsc.org]
6. Tetrahydropyridines: a recent update for their multicomponent synthesis - PMC [[pmc.ncbi.nlm.nih.gov](https://pubmed.ncbi.nlm.nih.gov/)]
7. Primary Amine-Catalyzed Biginelli Reaction for the Enantioselective Synthesis of 3,4-Dihydropyrimidin-2(1H)-ones - PMC [[pmc.ncbi.nlm.nih.gov](https://pubmed.ncbi.nlm.nih.gov/)]

- [8. pdf.benchchem.com \[pdf.benchchem.com\]](https://pdf.benchchem.com)
- [9. benthamscience.com \[benthamscience.com\]](https://benthamscience.com)
- To cite this document: BenchChem. [Technical Support Center: Optimizing Tetrahydropyridopyrimidine Synthesis]. BenchChem, [2026]. [Online PDF]. Available at: [<https://www.benchchem.com/product/b1449735/docs#technical-support-center-optimizing-tetrahydropyridopyrimidine-synthesis>]

Disclaimer & Data Validity:

The information provided in this document is for Research Use Only (RUO) and is strictly not intended for diagnostic or therapeutic procedures. While BenchChem strives to provide accurate protocols, we make no warranties, express or implied, regarding the fitness of this product for every specific experimental setup.

Technical Support: The protocols provided are for reference purposes. Unsure if this reagent suits your experiment?

Need Industrial/Bulk Grade? [Request Custom Synthesis Quote](#)

BenchChem

Our mission is to be the trusted global source of essential and advanced chemicals, empowering scientists and researchers to drive progress in science and industry.

Contact

Address: 3281 E Guasti Rd
Ontario, CA 91761, United States
Phone: (601) 213-4426
Email: info@benchchem.com

[Contact our Ph.D. Support Team for a compatibility check](#)