

Strategic pKa Modulation: The -Fluorination of Primary Amines

Author: BenchChem Technical Support Team. **Date:** May 2026

Compound of Interest

Compound Name: *(R)-1-Fluoro-2-propylamine Hydrochloride*
CAS No.: 273734-17-1
Cat. No.: B1449289

[Get Quote](#)

Technical Guide for Medicinal Chemistry & Lead Optimization

Executive Summary

In modern drug discovery, the primary amine is a ubiquitous but problematic pharmacophore. While essential for solubility and target engagement, its high basicity (typically pKa 10–11) often leads to poor membrane permeability, high efflux liability, and off-target toxicity—most notably hERG channel inhibition.

This guide details the strategic application of

-fluorination to modulate amine pKa.^{[1][2]} By exploiting the strong inductive effect (

) of fluorine at the

-position, researchers can lower the pKa by 1.5 to 5.0 log units without significantly altering steric bulk. This modification increases the fraction of neutral species at physiological pH (

), thereby enhancing passive permeability while simultaneously reducing cation-driven hERG binding.

The Physicochemical Basis

The Inductive Effect & pKa Shift

The introduction of fluorine atoms at the

-carbon creates a strong electron-withdrawing inductive effect (

). This withdraws electron density from the nitrogen lone pair, destabilizing the protonated ammonium species (

) and thereby increasing the acidity of the conjugate acid (lowering the pKa).

Table 1: Impact of

-Fluorination on Ethylamine Basicity

Compound	Structure	pKa (Conj.[1] [3][4][5][6][7] Acid)	pKa (vs. Ethylamine)	LogP (Approx)
Ethylamine		10.7	Ref	-0.13
2- Fluoroethylamine		~9.2	-1.5	-0.45
2,2- Difluoroethylamine		~7.5	-3.2	-0.20
2,2,2- Trifluoroethylamine		5.7	-5.0	+0.40

Data Sources: pKa values derived from experimental datasets [1][2].

The Gauche Effect

Beyond simple induction,

-fluoroamines exhibit a stereoelectronic phenomenon known as the gauche effect. The C–F bond and the C–N bond tend to adopt a gauche conformation (60° dihedral angle) rather than anti.

- Mechanism: This is driven by hyperconjugation () and electrostatic attraction between the partially negative fluorine and the partially positive ammonium hydrogen ().
- Consequence: This conformational lock can pre-organize the molecule for receptor binding, potentially reducing the entropic penalty of binding.

Strategic Application in Drug Design

Mitigating hERG Liability

Inhibition of the hERG potassium channel is a major cause of cardiotoxicity (QT prolongation). hERG binding is strongly correlated with the presence of a basic center and high lipophilicity.

- The Fix: Lowering the pKa below 8.0 reduces the concentration of the cationic species at physiological pH (7.4).
- Result: A trifluoroethyl group (pKa 5.7) is predominantly neutral at pH 7.4, significantly reducing affinity for the cation-selective hERG pore [3].

Improving Permeability

Passive membrane diffusion requires the molecule to be in its neutral state.

- Ethylamine (pKa 10.7): At pH 7.4, >99.9% is ionized (). Permeability is low.[5]
- Difluoroethylamine (pKa 7.5): At pH 7.4, ~44% is neutral. Permeability is significantly enhanced.

Visualization of the Optimization Pathway

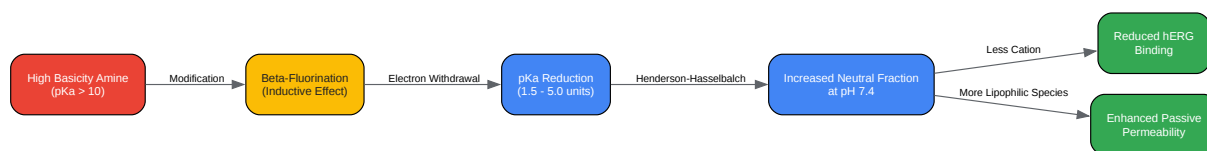

[Click to download full resolution via product page](#)

Figure 1: The mechanistic pathway connecting

-fluorination to improved ADMET properties.

Synthetic Methodologies

The most direct route to

-fluoroamines is the deoxofluorination of

-amino alcohols. While DAST (Diethylaminosulfur trifluoride) is the classical reagent, it is thermally unstable. Modern protocols prefer XtalFluor-E or Deoxo-Fluor for enhanced safety and selectivity.

Protocol: Deoxofluorination of N-Protected -Amino Alcohols

Note: This protocol assumes the use of a Boc-protected amino alcohol to prevent side reactions with the nitrogen.

Reagents:

- Substrate: N-Boc-2-aminoethanol derivative (1.0 eq)
- Reagent: DAST or Deoxo-Fluor (1.2 eq)
- Solvent: Anhydrous Dichloromethane (DCM)
- Quench: Saturated aqueous

Step-by-Step Workflow:

- Preparation: Flame-dry a round-bottom flask and purge with Nitrogen (). Add the N-Boc-amino alcohol and dissolve in anhydrous DCM (0.1 M concentration).
- Cooling: Cool the solution to -78°C using a dry ice/acetone bath. Critical: Low temperature prevents elimination to the enamine or oxazoline formation.
- Addition: Add DAST dropwise via syringe over 10 minutes. Maintain temperature at -78°C .
- Reaction: Stir at -78°C for 1 hour, then allow the mixture to slowly warm to room temperature (RT) over 4–12 hours. Monitor by TLC or LCMS.
- Quench (Safety Critical): Cool the mixture back to 0°C . Slowly add saturated . Warning: Vigorous gas evolution (, HF) will occur.
- Extraction: Extract the aqueous layer with DCM (3x). Combine organics, dry over , and concentrate.
- Purification: Purify via silica gel flash chromatography (typically Hexanes/EtOAc).
- Deprotection: Treat the purified intermediate with TFA/DCM (1:1) or HCl/Dioxane to yield the free -fluoroamine salt.

Synthetic Pathway Visualization

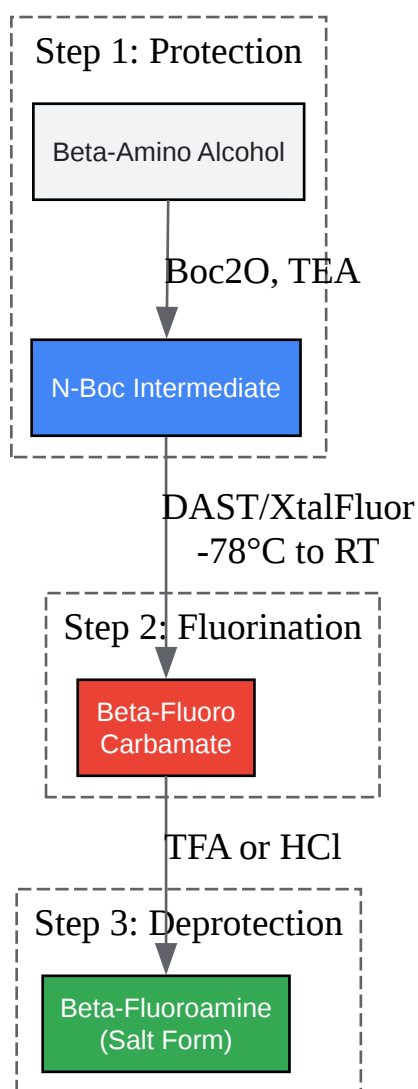

[Click to download full resolution via product page](#)

Figure 2: Step-wise synthetic workflow for converting amino alcohols to fluoroamines.

Analytical Validation

Validating the pKa shift is critical before proceeding to biological assays.

- Potentiometric Titration: The gold standard. Requires ~5-10 mg of compound. Perform in 0.15 M KCl at 25°C.
- NMR Shift Analysis: The chemical shift of the fluorine atom is sensitive to the protonation state of the neighbor nitrogen.

- Method: Titrate the amine in
with NaOD/DCl while monitoring the
signal. Plot chemical shift (
) vs. pH to determine the inflection point (pKa).

References

- PubChem. (2025).[3] Ethanamine, 2,2,2-trifluoro- | C₂H₄F₃N.[8] National Library of Medicine. Available at: [\[Link\]](#)
- Morgenthaler, M., et al. (2007). Predicting and Tuning Physicochemical Properties in Lead Optimization: Amine Basicities. ChemMedChem. Available at: [\[Link\]](#)
- Pike, K. G., et al. (2011). Optimisation of hERG and Pharmacokinetic Properties for Basic Dihydro-8H-purin-8-one Inhibitors of DNA-PK. Bioorganic & Medicinal Chemistry Letters. Available at: [\[Link\]](#)
- Sittihan, S., et al. (2025).[9] Enantioselective Synthesis of Beta-Fluoroamines. Organic Letters. Available at: [\[Link\]](#)
- Cambridge MedChem Consulting. (2023). Tuning Basicity. Available at: [\[Link\]](#)

Need Custom Synthesis?

BenchChem offers custom synthesis for rare earth carbides and specific isotopic labeling.

Email: info@benchchem.com or [Request Quote Online](#).

Sources

- 1. α,β -Desaturation and Formal β -C(sp³)-H Fluorination of N-Substituted Amines: A Late-Stage Functionalization Strategy Enabled by Electrochemistry - PMC [[pmc.ncbi.nlm.nih.gov](https://pubmed.ncbi.nlm.nih.gov/)]
- 2. A general, enantioselective synthesis of β - and γ -fluoroamines - PMC [[pmc.ncbi.nlm.nih.gov](https://pubmed.ncbi.nlm.nih.gov/)]

- [3. Ethanamine, 2,2,2-trifluoro- | C2H4F3N | CID 9773 - PubChem \[pubchem.ncbi.nlm.nih.gov\]](#)
- [4. masterorganicchemistry.com \[masterorganicchemistry.com\]](#)
- [5. drughunter.com \[drughunter.com\]](#)
- [6. Tuning basicity | Cambridge MedChem Consulting \[cambridgemedchemconsulting.com\]](#)
- [7. researchgate.net \[researchgate.net\]](#)
- [8. 2,2,2-TRIFLUOROETHYLAMINE | 753-90-2 \[chemicalbook.com\]](#)
- [9. \$\beta\$ -Amino alcohol synthesis by amination \(alkylation\) \[organic-chemistry.org\]](#)
- To cite this document: BenchChem. [Strategic pKa Modulation: The -Fluorination of Primary Amines]. BenchChem, [2026]. [Online PDF]. Available at: [\[https://www.benchchem.com/product/b1449289/docs#strategic-pka-modulation-the-fluorination-of-primary-amines\]](https://www.benchchem.com/product/b1449289/docs#strategic-pka-modulation-the-fluorination-of-primary-amines)

Disclaimer & Data Validity:

The information provided in this document is for Research Use Only (RUO) and is strictly not intended for diagnostic or therapeutic procedures. While BenchChem strives to provide accurate protocols, we make no warranties, express or implied, regarding the fitness of this product for every specific experimental setup.

Technical Support: The protocols provided are for reference purposes. Unsure if this reagent suits your experiment?

Need Industrial/Bulk Grade? [Request Custom Synthesis Quote](#)

BenchChem

Our mission is to be the trusted global source of essential and advanced chemicals, empowering scientists and researchers to drive progress in science and industry.

Contact

Address: 3281 E Guasti Rd

Ontario, CA 91761, United States

Phone: (601) 213-4426

Email: info@benchchem.com

Contact our Ph.D. Support Team for a compatibility check