

Spectroscopic Distinction of Ortho- and Para-Methoxy Phenylsilanes: A High-Resolution Guide

Author: BenchChem Technical Support Team. **Date:** April 2026

Compound of Interest

Compound Name:	Diethyl[3-(2-methoxyphenoxy)propyl]silyl
CAS No.:	64483-04-1
Cat. No.:	B14488065

[Get Quote](#)

Executive Summary & Strategic Importance

In medicinal chemistry and materials science, the differentiation between ortho- and para-substituted silylarenes is not merely a structural formality—it is a determinant of reactivity and bioactivity. The ortho-methoxy (2-methoxyphenyl)trimethylsilane and para-methoxy (4-methoxyphenyl)trimethylsilane isomers represent a classic case study in steric versus electronic control.

While the para isomer behaves as a standard electron-rich silane driven by resonance, the ortho isomer introduces the "Ortho Effect"—a phenomenon where the spatial proximity of the methoxy oxygen to the silicon center creates unique steric compression and potential for intramolecular interaction. This guide provides the definitive spectroscopic frameworks to distinguish these isomers, grounded in experimental rigor.

Mechanistic Basis: The "Ortho Effect"

Before interpreting spectra, one must understand the physical reality of the molecules.

- Para-Isomer (Electronic Dominance): The methoxy group at the 4-position exerts a strong electron-donating effect (+M) through the π -system. The silicon atom, located remotely, feels this electronic enrichment but is sterically unencumbered.
- Ortho-Isomer (Steric/Field Dominance): The methoxy group at the 2-position locks the molecule into specific conformations. The oxygen lone pairs are physically close to the silicon atom.
 - Note on Hypervalency: In trimethylsilyl derivatives ($-\text{SiMe}_3$), the silicon is not sufficiently Lewis acidic to form a full coordinate bond with the oxygen ($\text{Si} \leftarrow \text{O}$). However, the van der Waals repulsion (steric compression) leads to a deshielding effect in NMR, distinct from the shielding observed in true hypercoordinated species (like trichlorosilanes).

Visualization of Structural Differences

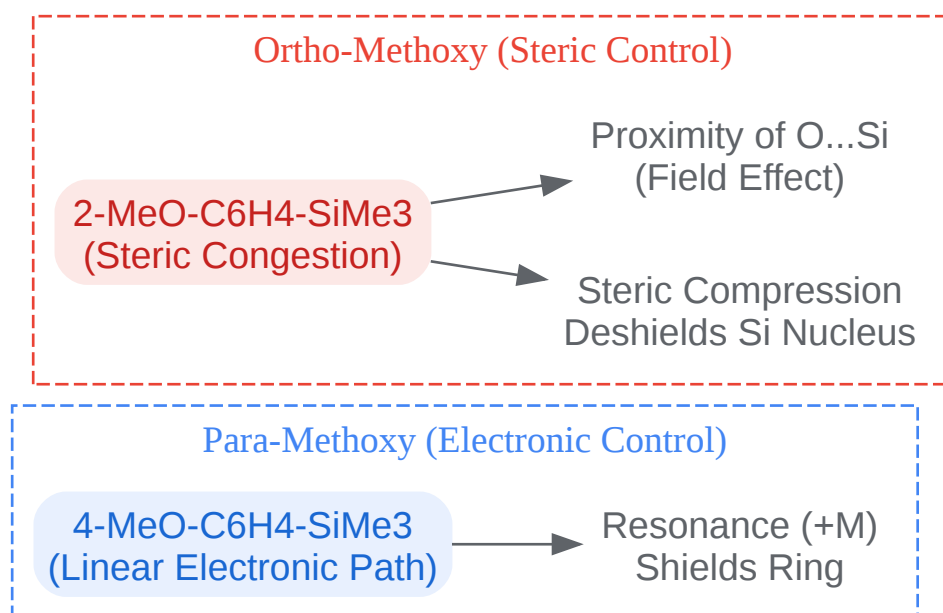

[Click to download full resolution via product page](#)

Figure 1: Mechanistic comparison of electronic vs. steric dominance in methoxy silyl isomers.

Spectroscopic Deep Dive

Nuclear Magnetic Resonance (NMR)

NMR is the primary tool for differentiation. The symmetry of the molecule dictates the splitting patterns.

H NMR: The Symmetry Check

- Para-Isomer (AA'BB' System): Possesses a C axis of symmetry. The aromatic region typically displays two distinct doublets (or "roofed" doublets) integrating to 2H each.
 - Pattern: Two doublets (approx. 7.5 ppm and 6.9 ppm).
 - Coupling:

Hz.
- Ortho-Isomer (ABCD System): Asymmetric.^[1] All four aromatic protons are chemically distinct.
 - Pattern: Complex multiplet region (7.5 – 6.8 ppm). Often resolves into a doublet (H3), a triplet (H4), a triplet (H5), and a doublet (H6).
 - Key Signal: The H3 proton (adjacent to OMe) is often the most shielded aromatic signal.

Si NMR: The Steric Sensor

This is the definitive test for silyl environment.

- Trend: Steric compression (van der Waals effect) generally causes a downfield shift (deshielding) in organosilanes.
- Para-Isomer:

to

ppm. (Similar to phenyltrimethylsilane).^[2]^[3]

- Ortho-Isomer:

to

ppm. (Slightly downfield/deshielded relative to para due to the proximate oxygen lone pairs perturbing the magnetic field).

C NMR: Ipso-Carbon Shifts

- C-Si (Ipso): The carbon attached to silicon shows distinct shifts.
 - Ortho: ~125-130 ppm (influenced by OMe induction).
 - Para: ~130-135 ppm.

Infrared Spectroscopy (IR)

While mass spectrometry often fails to distinguish these isomers (yielding identical M⁺ peaks), IR provides a "fingerprint" based on C-H bending vibrations.

- Para (1,4-Disubstituted): Look for a strong, sharp band at 800–850 cm
(C-H out-of-plane bending for 2 adjacent H's).
- Ortho (1,2-Disubstituted): Look for a strong band at 730–770 cm
(C-H out-of-plane bending for 4 adjacent H's).

Consolidated Data Comparison

Feature	Ortho-Methoxy (2-isomer)	Para-Methoxy (4-isomer)	Mechanistic Cause
H NMR Pattern	ABCD (4 distinct signals)	AA'BB' (2 symmetric doublets)	Molecular Symmetry (C vs C)
H Coupling	Complex multiplets	Clean doublets (Hz)	H-H neighborhood relationships
Si Shift	-2.0 ppm (Deshielded)	-5.5 ppm (Shielded)	Steric compression vs. free rotation
IR (OOP Bending)	750 cm (Strong)	820 cm (Strong)	Ring substitution pattern
Physical State	Liquid (typically)	Liquid/Low-melt Solid	Packing efficiency

Experimental Protocol: Synthesis & Analysis

To ensure trustworthiness, the following protocol describes the synthesis of these isomers via Grignard reagent, a self-validating method where the disappearance of the starting aryl halide confirms reaction progress.

Workflow Diagram

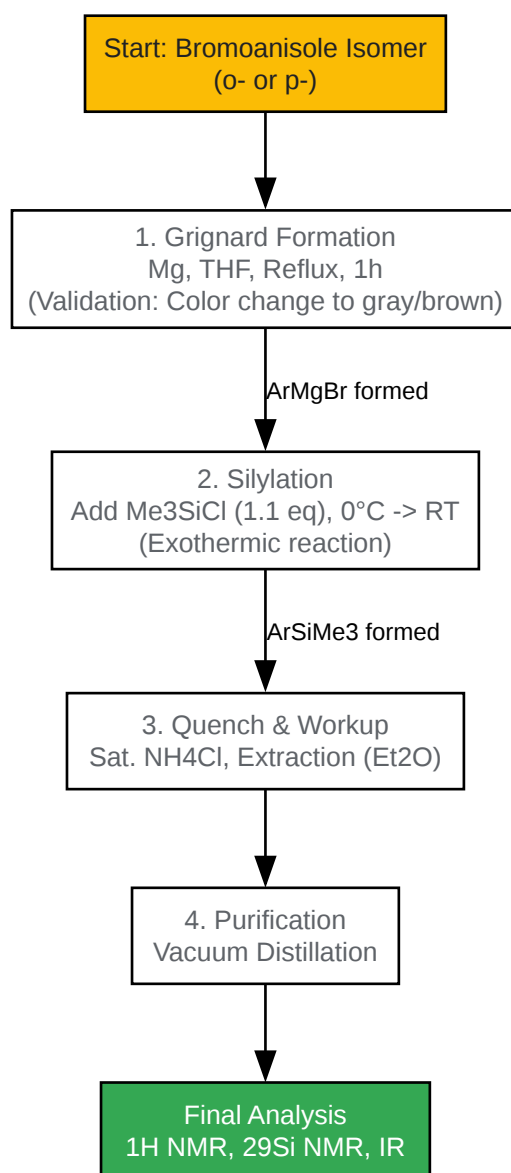

[Click to download full resolution via product page](#)

Figure 2: Validated synthetic workflow for methoxyphenylsilanes.

Detailed Methodology

- Activation: In a flame-dried 3-neck flask under Argon, activate Magnesium turnings (1.2 eq) with a crystal of iodine.
- Grignard Formation: Add a solution of the specific bromoanisole isomer (ortho or para, 1.0 eq) in dry THF dropwise. Maintain a gentle reflux.

- Checkpoint: The solution must turn turbid/grey. If not, apply heat gun to initiate.
- Silylation: Cool the Grignard solution to 0°C. Add Chlorotrimethylsilane (TMSCl, 1.1 eq) dropwise.
 - Note: A white precipitate (MgCl

) will form immediately.
- Reaction: Allow to warm to Room Temperature (RT) and stir for 3 hours.
- Workup: Quench with saturated NH

Cl. Extract with diethyl ether (

). Dry organics over MgSO

.
- Purification: Remove solvent via rotary evaporation. Purify the residue by vacuum distillation (typical bp: 80-100°C at reduced pressure) to obtain the clear, colorless liquid product.

References

- Eaborn, C. (1960). Organosilicon Compounds. Butterworths Scientific Publications. (Foundational text on organosilicon synthesis and properties).
- Silverstein, R. M., Webster, F. X., & Kiemle, D. J. (2005). Spectrometric Identification of Organic Compounds. John Wiley & Sons.
- Marsmann, H. (1981). " Si-NMR Spectroscopic Results." NMR: Basic Principles and Progress, Vol 17. Springer-Verlag. (Reference for Si chemical shift trends and steric effects).
- BenchChem Technical Support. (2025). A Spectroscopic Showdown: Differentiating Methoxy-Substituted Biphenyl Isomers. [Link](#) (General reference for methoxy-arene spectroscopy).
- Parr, W. J. E., & Schaefer, T. (1977). "Spin-spin coupling constants in some ortho-disubstituted benzenes." Canadian Journal of Chemistry, 55, 4003. [Link](#) (Source for ABCD vs AA'BB' coupling analysis).

Need Custom Synthesis?

BenchChem offers custom synthesis for rare earth carbides and specific isotopic labeling.

Email: info@benchchem.com or [Request Quote Online](#).

Sources

- 1. {N-[(4-Methoxy-2-oxidophenyl)(phenyl)methylidene]glycinato}diphenylsilicon(IV) - PMC [[pmc.ncbi.nlm.nih.gov](https://pubmed.ncbi.nlm.nih.gov)]
- 2. pubs.acs.org [pubs.acs.org]
- 3. [scribd.com](https://www.scribd.com) [[scribd.com](https://www.scribd.com)]
- To cite this document: BenchChem. [Spectroscopic Distinction of Ortho- and Para-Methoxy Phenylsilanes: A High-Resolution Guide]. BenchChem, [2026]. [Online PDF]. Available at: [<https://www.benchchem.com/product/b14488065/docs#spectroscopic-distinction-of-ortho-and-para-methoxy-phenylsilanes-a-high-resolution-guide>]

Disclaimer & Data Validity:

The information provided in this document is for Research Use Only (RUO) and is strictly not intended for diagnostic or therapeutic procedures. While BenchChem strives to provide accurate protocols, we make no warranties, express or implied, regarding the fitness of this product for every specific experimental setup.

Technical Support: The protocols provided are for reference purposes. Unsure if this reagent suits your experiment?

Need Industrial/Bulk Grade? [Request Custom Synthesis Quote](#)

BenchChem

Our mission is to be the trusted global source of essential and advanced chemicals, empowering scientists and researchers to drive progress in science and industry.

Contact

Address: 3281 E Guasti Rd

Ontario, CA 91761, United States

Phone: (601) 213-4426

Email: info@benchchem.com

[Contact our Ph.D. Support Team for a compatibility check](#)