

# Technical Guide: GC-MS Characterization of 2-Methyl-4-phenylbut-2-enenitrile

**Author:** BenchChem Technical Support Team. **Date:** May 2026

## Compound of Interest

Compound Name: 2-Methyl-4-phenylbut-2-enenitrile

CAS No.: 63909-26-2

Cat. No.: B14486625

[Get Quote](#)

## Executive Summary

This guide provides an in-depth technical analysis of the gas chromatography-mass spectrometry (GC-MS) fragmentation patterns of **2-Methyl-4-phenylbut-2-enenitrile** (MW 157 Da). Often encountered as a specific impurity in the synthesis of phenyl-substituted aliphatic nitriles or as a degradation product in fragrance stability studies, this molecule presents unique identification challenges due to its structural similarity to regioisomers like 2-benzylbut-2-enenitrile and 3-methyl-4-phenylbut-3-enenitrile.

We objectively compare its spectral signature against key alternatives, establishing a self-validating protocol for unambiguous identification.

## Chemical Identity & Structural Context[1][2][3][4][5]

- IUPAC Name: **2-Methyl-4-phenylbut-2-enenitrile**
- Molecular Formula: C

H

N

- Molecular Weight: 157.21 g/mol
- Structure:
- Key Features: A conjugated nitrile system with a benzylic methylene group, making it prone to specific allylic/benzylic cleavages.

## Experimental Protocol (Standardized)

To ensure reproducibility, the following GC-MS conditions are recommended. This protocol minimizes thermal degradation and maximizes isomer resolution.

Table 1: Recommended GC-MS Parameters

Parameter	Setting / Specification	Rationale
Column	DB-5ms or Rxi-5Sil MS (30m x 0.25mm x 0.25µm)	Low-bleed, non-polar phase separates isomers based on boiling point and shape selectivity.
Carrier Gas	Helium @ 1.0 mL/min (Constant Flow)	Standard for EI-MS; constant flow maintains retention time stability.
Inlet Temp	250°C (Split 20:1)	High enough to volatilize, split ratio prevents column overload.
Oven Program	60°C (1 min) → 10°C/min → 280°C (5 min)	Slow ramp in the 120-180°C range is critical for separating phenylbutenenitrile isomers.
Ion Source	EI (70 eV), 230°C	Standard electron ionization energy for library comparison.
Mass Range	m/z 40–350	Covers low mass fragments (m/z 41) and potential dimers.

## Fragmentation Analysis (Mechanism & Diagnostics)

The mass spectrum of **2-Methyl-4-phenylbut-2-enenitrile** is dominated by the stability of the benzyl/tropylium ion. The fragmentation pathway is driven by the weakness of the allylic C-C bond relative to the aromatic ring.

### Primary Fragmentation Pathway

- Molecular Ion (M

, m/z 157): Visible but of moderate intensity (20-40%). The conjugated system confers some stability to the radical cation.

- Base Peak (m/z 91): The formation of the tropylium ion (C

H

) is the dominant process.

- Mechanism: Cleavage of the allylic C3-C4 bond ( ).
- This releases a neutral radical and the stable benzyl cation, which rearranges to tropylium.
- Diagnostic Fragment (m/z 142): Loss of Methyl radical ( ).
  - Mechanism: Cleavage of the methyl group attached to the C2 position.
- Nitrile Loss (m/z 130): Loss of HCN ( ).
  - Common in unsaturated nitriles, involving hydrogen rearrangement from the methylene group.
- Phenyl Cation (m/z 77): Decomposition of the tropylium ion or direct phenyl cleavage.

## Visualization of Signaling Pathway

The following diagram illustrates the competitive fragmentation kinetics.

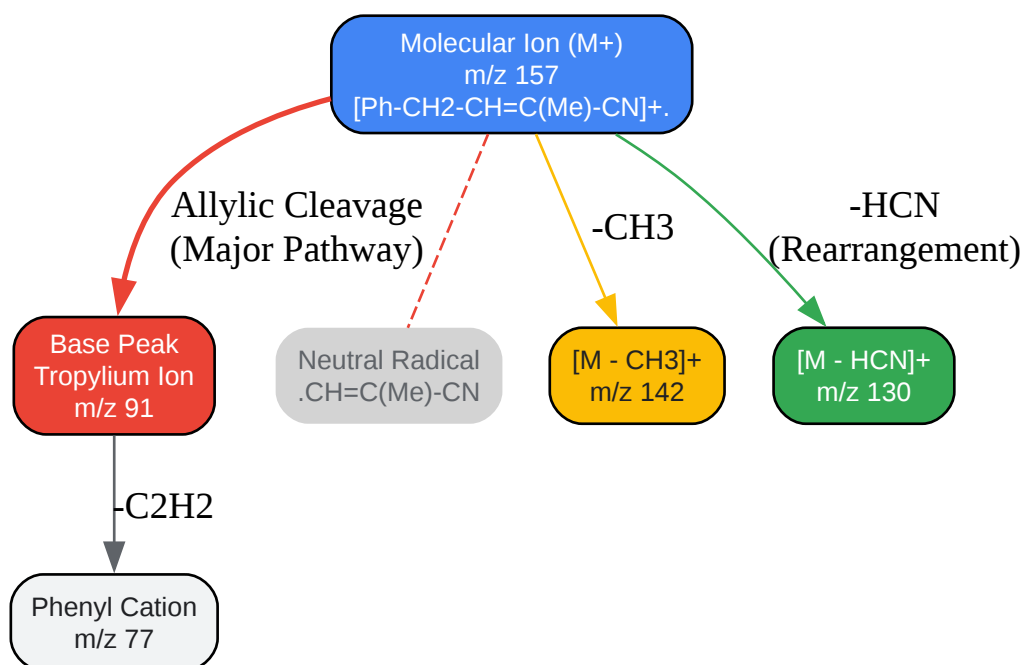

[Click to download full resolution via product page](#)

Caption: Figure 1. Competitive fragmentation pathways for **2-Methyl-4-phenylbut-2-enenitrile** under 70 eV EI conditions.

## Comparative Analysis: Target vs. Alternatives

Differentiation from isomers is the critical challenge. The two most common interfering compounds are 2-Benzyl-2-butenenitrile (a structural isomer) and 2-Methyl-3-phenylacrylonitrile (a homolog often present in similar mixtures).

## Comparison Table

Table 2: Spectral & Chromatographic Differentiation

Feature	Target: <b>2-Methyl-4-phenylbut-2-enenitrile</b>	Alt 1: <b>2-Benzyl-2-butenenitrile</b>	Alt 2: <b>2-Methyl-3-phenylacrylonitrile</b>
Structure	Ph-CH -CH=C(Me)-CN	CH -CH=C(Bn)-CN	Ph-CH=C(Me)-CN
MW	157	157	143
Base Peak	m/z 91 (Tropylium)	m/z 91 (Tropylium)	m/z 143 (Molecular Ion) or 116
Key Diagnostic	m/z 66 (Low intensity, complementary to 91)	m/z 66 (Often higher intensity due to sterics)	m/z 116 (M-HCN)
Retention Index (DB-5)	~1450 - 1480	~1420 - 1440	~1250 - 1280
Mechanism Note	Allylic cleavage is unobstructed.	Steric crowding at the benzyl attachment can alter ion ratios.	Fully conjugated system; very stable M+.

## Decision Logic for Identification

When analyzing a complex mixture (e.g., reaction crude), use this logic flow to confirm identity.

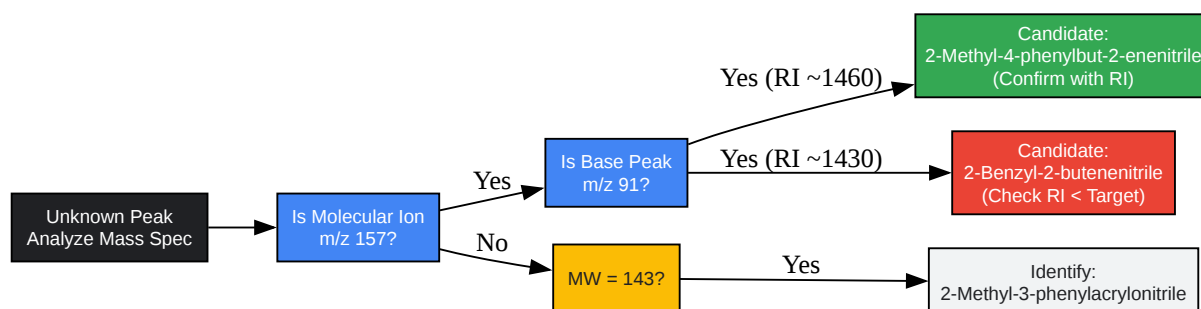

[Click to download full resolution via product page](#)

Caption: Figure 2. Logical decision tree for differentiating phenyl-nitrile derivatives based on MS and Retention Index.

## Synthesis of Insights

- **Causality of Base Peak:** The  $m/z$  91 peak is not generic; it specifically confirms the presence of a benzyl group attached to a "cleavable" weak link (the allylic bond). If the phenyl ring were directly attached to the double bond (as in styrene derivatives), the molecular ion would be the base peak.
- **Isomer Trap:** Both the target and "Alt 1" (2-Benzyl-2-butenenitrile) share the  $m/z$  91 base peak and MW 157. Mass spectrometry alone is insufficient for distinction. You must rely on Retention Index (RI). The target molecule, being more linear/less sterically hindered than the branched 2-benzyl isomer, typically elutes later on non-polar columns.
- **Protocol Validation:** To validate your assignment, run a standard of Toluene ( $m/z$  91 source) and Benzonitrile ( $m/z$  103 source) to calibrate the mass axis accuracy, as a 0.5  $m/z$  shift can confuse  $m/z$  91 with  $m/z$  92 (McLafferty rearrangement product in other isomers).

## References

- NIST Mass Spectrometry Data Center. (2023). NIST / EPA / NIH Mass Spectral Library (EI). National Institute of Standards and Technology. [\[Link\]](#)
- Sparkman, O. D. (2005). Mass Spectrometry Desk Reference. Global View Publishing.
- Silverstein, R. M., et al. (2014). Spectrometric Identification of Organic Compounds. Wiley. [\[Link\]](#)
- PubChem. (2024). Compound Summary: Phenylbutenenitrile Derivatives. National Library of Medicine. [\[Link\]](#)
- [To cite this document: BenchChem. \[Technical Guide: GC-MS Characterization of 2-Methyl-4-phenylbut-2-enenitrile\]. BenchChem, \[2026\]. \[Online PDF\]. Available at: <https://www.benchchem.com/product/b14486625/docs#technical-guide-gc-ms-characterization-of-2-methyl-4-phenylbut-2-enenitrile>](#)

**Disclaimer & Data Validity:**

The information provided in this document is for Research Use Only (RUO) and is strictly not intended for diagnostic or therapeutic procedures. While BenchChem strives to provide accurate protocols, we make no warranties, express or implied, regarding the fitness of this product for every specific experimental setup.

**Technical Support:** The protocols provided are for reference purposes. Unsure if this reagent suits your experiment?

**Need Industrial/Bulk Grade?** [Request Custom Synthesis Quote](#)

## BenchChem

Our mission is to be the trusted global source of essential and advanced chemicals, empowering scientists and researchers to drive progress in science and industry.

### Contact

Address: 3281 E Guasti Rd  
Ontario, CA 91761, United States  
Phone: (601) 213-4426  
Email: [info@benchchem.com](mailto:info@benchchem.com)

[Contact our Ph.D. Support Team for a compatibility check](#)