

Spectroscopic Characterization of 2-Methoxydecanoic Acid: A Technical Guide

Author: BenchChem Technical Support Team. **Date:** April 2026

Compound of Interest

Compound Name:	2-Methoxydecanoic acid
CAS No.:	66018-29-9
Cat. No.:	B14473127

[Get Quote](#)

Executive Summary & Compound Profile

2-Methoxydecanoic acid (2-MDA) is a synthetic

-methoxylated fatty acid derivative. Unlike canonical fatty acids, the introduction of a methoxy group at the

-carbon (C2) significantly alters its physicochemical properties, enhancing metabolic stability against

-oxidation and increasing antimicrobial potency, particularly against mycobacteria.

This guide provides a definitive reference for the identification of 2-MDA using Nuclear Magnetic Resonance (NMR), Infrared (IR) Spectroscopy, and Mass Spectrometry (MS). The data presented here allows for the differentiation of 2-MDA from its non-methoxylated parent (decanoic acid) and its methyl ester analogs.

Compound Identity

Parameter	Detail
IUPAC Name	2-Methoxydecanoic acid
Molecular Formula	
Molecular Weight	202.29 g/mol
CAS Registry	Derivative of 2-hydroxydecanoic acid
Physical State	Viscous oil or low-melting solid (at RT)

Nuclear Magnetic Resonance (NMR) Spectroscopy

NMR is the primary tool for validating the

-methoxy substitution. The electronegative oxygen at C2 deshields both the C2 nucleus and the attached proton, creating distinct diagnostic shifts.

H NMR Analysis (400 MHz,)

The proton spectrum is characterized by the diagnostic singlet of the methoxy group and the downfield shift of the

-proton.

Position	(ppm)	Multiplicity	Integration	Assignment	Mechanistic Insight
-COOH	10.5 – 12.0	Broad Singlet	1H	Carboxylic Acid	Exchangeable proton; shift varies with concentration and solvent moisture.
H-2	3.75	dd or t	1H	-CH	Deshielded by both the carboxylic carbonyl (anisotropy) and the -methoxy oxygen (induction).
-OCH	3.45	Singlet	3H	Methoxy	Key Diagnostic: Sharp singlet distinct from ester methoxy (typically ~3.6-3.7 ppm).

H-3	1.70 – 1.85	Multiplet	2H	-CH	Shielded relative to H-2 but deshielded relative to bulk chain due to proximity to chiral center.
H-4 to H-9	1.25 – 1.40	Broad Multiplet	12H	Bulk CH	Characteristic "methylene envelope" of fatty acid chains.
H-10	0.88	Triplet	3H	Terminal CH	Standard terminal methyl group (Hz).

C NMR Analysis (100 MHz,)

The carbon spectrum confirms the backbone structure. The C2 signal is the most critical indicator of successful

-functionalization.

Carbon	(ppm)	Assignment	Structural Validation
C-1	176.5	C=O (Acid)	Typical carboxylic acid carbonyl; upfield from ketones/aldehydes.
C-2	80.2	-CH	Diagnostic: Significant downfield shift (approx +45 ppm vs decanoic acid) due to direct O-linkage.
-OCH	58.5	Methoxy	Confirms ether linkage. Methyl esters typically resonate lower (~51 ppm).
C-3	32.5	-CH	Slight deshielding due to -effect of the methoxy group.
C-9	22.7	-2 CH	Standard aliphatic chain resonance.
C-10	14.1	Terminal CH	Standard aliphatic terminus.

Infrared (IR) Spectroscopy

IR analysis is used primarily to confirm the presence of the carboxylic acid headgroup and the ether linkage, distinguishing the free acid from ester derivatives.^{[1][2]}

Key Absorption Bands^{[1][2][3][4][5]}

- O-H Stretch (Acid): A broad, intense band spanning 3300–2500 cm

. This "bearded" shape often overlaps with C-H stretches and is diagnostic of the hydrogen-bonded carboxylic acid dimer.[3]

- C=O Stretch (Acid): Strong band at 1710–1715 cm

.

- C-O-C Stretch (Ether): Distinct bands in the 1100–1150 cm

region, corresponding to the methoxy ether linkage. This differentiates 2-MDA from simple fatty acids.

- C-H Stretch (Alkyl): Sharp peaks at 2920 cm

(asymmetric) and 2850 cm

(symmetric) arising from the long aliphatic chain.

Mass Spectrometry (MS) & Fragmentation Logic

Mass spectrometry of

-substituted fatty acids follows specific fragmentation pathways driven by the stability of the heteroatom-stabilized carbocations.

Ionization Strategy

- Method: Electron Impact (EI, 70 eV) or Electrospray Ionization (ESI) in negative mode (

).

- Molecular Ion (

): m/z 202 (Weak in EI, prominent as

m/z 201 in ESI).

Fragmentation Pathway (EI)

The fragmentation is dominated by

-cleavage and McLafferty-type rearrangements modified by the methoxy group.[4]

- -Cleavage (Loss of COOH): Cleavage of the C1-C2 bond is favored, generating a resonance-stabilized oxonium ion.
 - ().
 - Note: This is often a high-abundance fragment for -methoxy acids.
- McLafferty Rearrangement: While typical for fatty acids (yielding m/z 60), the substitution at C2 alters the mass. The migration of a -hydrogen to the carbonyl oxygen typically yields a fragment containing the -substituent.
 - Fragment: is unlikely due to the acid group; instead, the rearrangement often leads to loss of the alkene chain or specific low MW ions like m/z 75 or 88 depending on precise geometry.
- Methoxy Group Loss:
 - .

Visualizing the Fragmentation Logic

The following diagram illustrates the critical fragmentation pathways used to validate the structure of **2-Methoxydecanoic acid**.

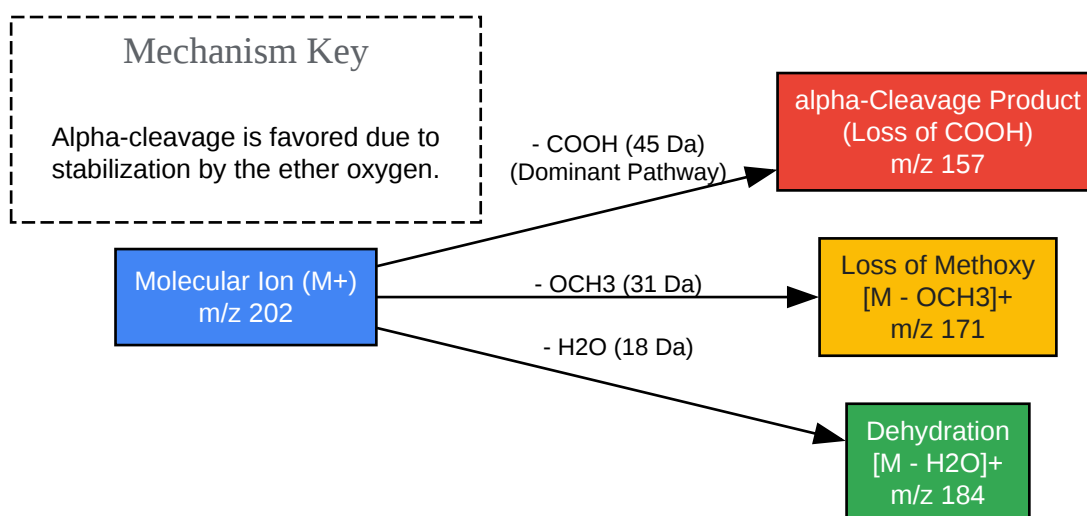

[Click to download full resolution via product page](#)

Figure 1: Primary EI-MS fragmentation pathways for **2-Methoxydecanoic acid**. The formation of the m/z 157 ion via alpha-cleavage is a diagnostic signature.

Experimental Protocols

Sample Preparation for NMR

To ensure sharp resolution of the

-proton coupling:

- Solvent: Use high-quality

(99.8% D) neutralized with basic alumina or silver foil to prevent acid-catalyzed exchange of the methoxy group, although the ether is generally stable.

- Concentration: Dissolve 10-20 mg of 2-MDA in 0.6 mL solvent.
- Reference: Calibrate to residual

at 7.26 ppm (

H) and 77.16 ppm (

C).

Derivatization for GC-MS

Direct GC analysis of free fatty acids leads to peak tailing. Methylation is NOT recommended as it converts the compound to methyl 2-methoxydecanoate, confusing the spectral interpretation (ester vs. ether methoxy).

- Recommended Protocol: Silylation using BSTFA (N,O-Bis(trimethylsilyl)trifluoroacetamide).
- Reaction: Incubate 1 mg sample + 50

L BSTFA + 50

L Pyridine at 60°C for 30 mins.

- Result: This yields the TMS-ester, shifting the molecular ion to m/z 274, allowing distinct separation from impurities.

References

- Carballeira, N. M., et al. (2017).^[5] 2-Methoxylated Fatty Acids Display Unusual Antibacterial Activity Towards Clinical Isolates of Methicillin-Resistant Staphylococcus aureus. ResearchGate.
- Anaikutti, P., et al. (2019). Characterization of ¹H and ¹³C NMR chemical shift values for isolated 2-methoxy mucic acid. ResearchGate.
- NIST Mass Spectrometry Data Center. (2023). Mass Spectrum of Decanoic acid, 2-methyl- (Analogous fragmentation patterns). NIST WebBook.
- LibreTexts Chemistry. (2024). Spectroscopy of Carboxylic Acids. Chemistry LibreTexts.

Need Custom Synthesis?

BenchChem offers custom synthesis for rare earth carbides and specific isotopic labeling.

Email: info@benchchem.com or [Request Quote Online](#).

Sources

- [1. 20.8 Spectroscopy of Carboxylic Acids and Nitriles - Organic Chemistry | OpenStax \[openstax.org\]](#)
- [2. chem.libretexts.org \[chem.libretexts.org\]](#)
- [3. orgchemboulder.com \[orgchemboulder.com\]](#)
- [4. Synthesis of a Novel Series of 2-Methylsulfanyl Fatty Acids and their Toxicity on the Human K-562 and U-937 Leukemia Cell Lines - PMC \[pmc.ncbi.nlm.nih.gov\]](#)
- [5. researchgate.net \[researchgate.net\]](#)
- To cite this document: BenchChem. [Spectroscopic Characterization of 2-Methoxydecanoic Acid: A Technical Guide]. BenchChem, [2026]. [Online PDF]. Available at: [\[https://www.benchchem.com/product/b14473127/docs#spectroscopic-characterization-of-2-methoxydecanoic-acid-a-technical-guide\]](https://www.benchchem.com/product/b14473127/docs#spectroscopic-characterization-of-2-methoxydecanoic-acid-a-technical-guide)

Disclaimer & Data Validity:

The information provided in this document is for Research Use Only (RUO) and is strictly not intended for diagnostic or therapeutic procedures. While BenchChem strives to provide accurate protocols, we make no warranties, express or implied, regarding the fitness of this product for every specific experimental setup.

Technical Support: The protocols provided are for reference purposes. Unsure if this reagent suits your experiment?

Need Industrial/Bulk Grade? [Request Custom Synthesis Quote](#)

BenchChem

Our mission is to be the trusted global source of essential and advanced chemicals, empowering scientists and researchers to drive progress in science and industry.

Contact

Address: 3281 E Guasti Rd
Ontario, CA 91761, United States
Phone: (601) 213-4426
Email: info@benchchem.com

Contact our Ph.D. Support Team for a compatibility check