

# 2-Methoxydecanoic acid experimental protocols

**Author:** BenchChem Technical Support Team. **Date:** April 2026

## Compound of Interest

Compound Name: *2-Methoxydecanoic acid*

CAS No.: 66018-29-9

Cat. No.: B14473127

[Get Quote](#)

An In-Depth Guide to the Experimental Application of **2-Methoxydecanoic Acid**

## Authored by a Senior Application Scientist

This document serves as a comprehensive technical guide for researchers, scientists, and drug development professionals working with **2-Methoxydecanoic acid**. It provides a holistic overview, from chemical synthesis and characterization to safe handling and application in biological assays. The protocols herein are designed to be self-validating, with an emphasis on the scientific rationale behind each procedural step to ensure experimental robustness and reproducibility.

## Introduction and Scientific Context

**2-Methoxydecanoic acid** is a saturated fatty acid characterized by a methoxy group (-OCH<sub>3</sub>) at the alpha-position (C-2) of a ten-carbon chain. This structural feature is of significant scientific interest as alpha-methoxylated fatty acids are naturally synthesized by marine sponges and have been shown to possess intriguing biophysical and biological properties, including potent anticancer and antiprotozoal activities.[1][2] Unlike their non-methoxylated counterparts, the introduction of the methoxy group can enhance cytotoxicity against various cancer cell lines, making these compounds promising leads for therapeutic development.[3][4]

The study of **2-Methoxydecanoic acid** and its analogs provides a valuable opportunity to investigate structure-activity relationships. For instance, research on related compounds has demonstrated that the alpha-methoxy functionality, sometimes in combination with other structural features like unsaturation, is crucial for their enhanced biological effects.[3] This guide provides the foundational protocols necessary to synthesize, purify, and evaluate the biological efficacy of **2-Methoxydecanoic acid**.

## Synthesis, Purification, and Characterization

The reliable synthesis and rigorous characterization of **2-Methoxydecanoic acid** are paramount for obtaining meaningful and reproducible biological data. The most direct synthetic route involves the methylation of the corresponding  $\alpha$ -hydroxy fatty acid.

### Synthesis Protocol: Methylation of 2-Hydroxydecanoic Acid

The conversion of commercially available 2-hydroxydecanoic acid to **2-methoxydecanoic acid** is efficiently achieved through a Williamson ether synthesis, where the hydroxyl group is first deprotonated to form an alkoxide, which then acts as a nucleophile to attack a methylating agent.[5]

**Rationale:** This two-step, one-pot procedure is favored for its high yield and straightforward execution. Sodium hydride (NaH) is a strong base that irreversibly deprotonates the hydroxyl group, driving the formation of the reactive alkoxide. Dimethyl sulfoxide (DMSO) is an excellent solvent for this reaction. The subsequent saponification step with potassium hydroxide (KOH) ensures that any methyl ester formed as a byproduct is hydrolyzed back to the desired carboxylic acid.

Materials:

- ( $\pm$ )-2-Hydroxydecanoic acid[6][7]
- Sodium hydride (NaH), 60% dispersion in mineral oil
- Anhydrous Dimethyl sulfoxide (DMSO)
- Methyl iodide ( $\text{CH}_3\text{I}$ )

- Potassium hydroxide (KOH)
- Ethanol (EtOH)
- Hydrochloric acid (HCl), concentrated
- Diethyl ether
- Anhydrous magnesium sulfate (MgSO<sub>4</sub>)

#### Step-by-Step Protocol:

- Preparation: Under an inert atmosphere (Argon or Nitrogen), add 2-hydroxydecanoic acid (1.0 eq) to anhydrous DMSO in a round-bottom flask equipped with a magnetic stirrer.
- Deprotonation: Cool the solution to 0 °C in an ice bath. Carefully add sodium hydride (2.2 eq) portion-wise. Caution: NaH reacts violently with water and is flammable. Handle with extreme care.
- Methylation: After stirring for 30 minutes at 0 °C, add methyl iodide (2.2 eq) dropwise. Allow the reaction to warm to room temperature and stir for 3 hours.
- Saponification: Cool the reaction mixture back to 0 °C and slowly add a solution of KOH (4.0 eq) in ethanol. Heat the mixture to reflux for 2 hours to ensure complete hydrolysis of any ester intermediates.[\[1\]](#)[\[5\]](#)
- Work-up and Acidification: After cooling, pour the reaction mixture into a separatory funnel containing water. Wash with diethyl ether to remove mineral oil and unreacted methyl iodide. Acidify the aqueous layer to pH 1-2 with concentrated HCl.
- Extraction: Extract the acidified aqueous layer three times with diethyl ether.
- Drying and Concentration: Combine the organic extracts, dry over anhydrous magnesium sulfate, filter, and remove the solvent under reduced pressure using a rotary evaporator to yield the crude **2-Methoxydecanoic acid**.[\[8\]](#)

## Diagram: Synthesis Workflow

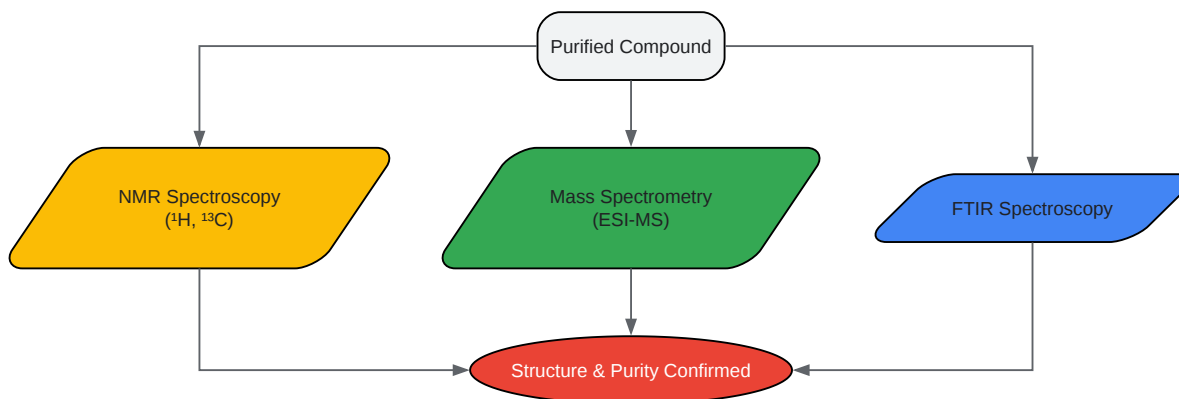
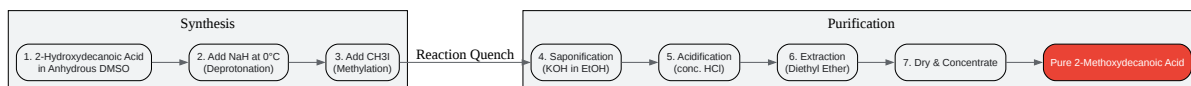

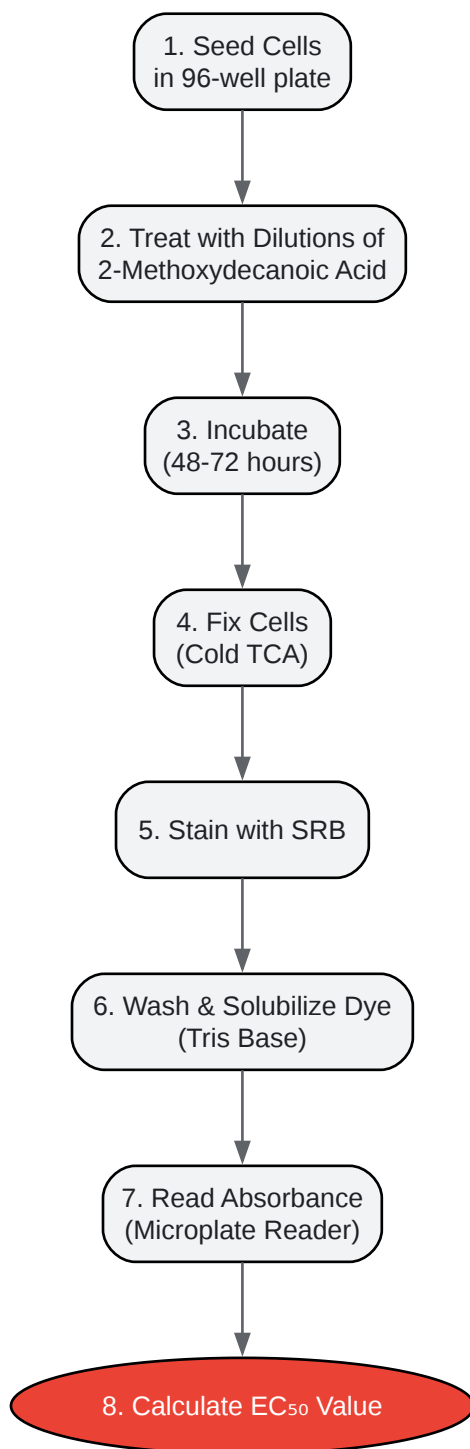

[Click to download full resolution via product page](#)

### Need Custom Synthesis?

BenchChem offers custom synthesis for rare earth carbides and specific isotopic labeling.

Email: [info@benchchem.com](mailto:info@benchchem.com) or [Request Quote Online](#).

## Sources

- [1. researchgate.net \[researchgate.net\]](#)
- [2. researchgate.net \[researchgate.net\]](#)
- [3. Synthesis of the novel \(±\)-2-methoxy-6-icosynoic acid – a fatty acid that induces death of neuroblastoma cells - PMC \[pmc.ncbi.nlm.nih.gov\]](#)
- [4. Synthesis of the novel \(±\)-2-methoxy-6-icosynoic acid--a fatty acid that induces death of neuroblastoma cells - PubMed \[pubmed.ncbi.nlm.nih.gov\]](#)
- [5. researchgate.net \[researchgate.net\]](#)
- [6. 2-Hydroxydecanoic Acid | C10H20O3 | CID 21488 - PubChem \[pubchem.ncbi.nlm.nih.gov\]](#)
- [7. CAS 5393-81-7: 2-Hydroxydecanoic acid | CymitQuimica \[cymitquimica.com\]](#)
- [8. Organic Syntheses Procedure \[orgsyn.org\]](#)
- To cite this document: BenchChem. [2-Methoxydecanoic acid experimental protocols]. BenchChem, [2026]. [Online PDF]. Available at: [\[https://www.benchchem.com/product/b14473127/docs#2-methoxydecanoic-acid-experimental-protocols\]](https://www.benchchem.com/product/b14473127/docs#2-methoxydecanoic-acid-experimental-protocols)

---

### Disclaimer & Data Validity:

The information provided in this document is for Research Use Only (RUO) and is strictly not intended for diagnostic or therapeutic procedures. While BenchChem strives to provide accurate protocols, we make no warranties, express or implied, regarding the fitness of this product for every specific experimental setup.

**Technical Support:** The protocols provided are for reference purposes. Unsure if this reagent suits your experiment?

**Need Industrial/Bulk Grade?** [Request Custom Synthesis Quote](#)

# BenchChem

Our mission is to be the trusted global source of essential and advanced chemicals, empowering scientists and researchers to drive progress in science and industry.

## Contact

Address: 3281 E Guasti Rd  
Ontario, CA 91761, United States  
Phone: (601) 213-4426  
Email: [info@benchchem.com](mailto:info@benchchem.com)

[Contact our Ph.D. Support Team for a compatibility check](#)