

Technical Support Center: Formylation of Substituted Pyridines

Author: BenchChem Technical Support Team. **Date:** April 2026

Compound of Interest

Compound Name: 4-Fluoro-2-methoxynicotinaldehyde
CAS No.: 1256835-96-7
Cat. No.: B1447602

[Get Quote](#)

A Guide for Researchers, Scientists, and Drug Development Professionals

Welcome to the Technical Support Center for the formylation of substituted pyridines. This guide, designed by Senior Application Scientists, provides in-depth troubleshooting advice and frequently asked questions (FAQs) to address the common challenges encountered during the synthesis of pyridine aldehydes. We understand the nuances of these reactions and aim to equip you with the knowledge to overcome common hurdles and achieve your desired synthetic outcomes.

Introduction to the Challenge

The formylation of pyridines, a seemingly straightforward transformation, is often fraught with difficulties. The inherent electron-deficient nature of the pyridine ring deactivates it towards classical electrophilic aromatic substitution reactions like the Vilsmeier-Haack and Rieche formylations.^{[1][2]} This low reactivity, coupled with the directing effects of various substituents, can lead to a range of side reactions, including low yields, poor regioselectivity, and undesired

byproducts. This guide will walk you through these challenges, providing expert insights and practical solutions.

Troubleshooting Guide

This section is designed to help you diagnose and solve specific problems you may encounter during the formylation of substituted pyridines.

Problem 1: Low or No Conversion of the Starting Pyridine

Q: I am not observing any significant formation of my desired pyridine aldehyde, and I am recovering most of my starting material. What is going wrong?

A: This is a very common issue, primarily due to the low nucleophilicity of the pyridine ring. Here are the likely causes and troubleshooting steps:

Possible Causes:

- **Deactivated Substrate:** Your pyridine contains one or more electron-withdrawing groups (e.g., -NO₂, -CN, -CF₃, halides) that further reduce the ring's electron density.[\[3\]](#)[\[4\]](#)
- **Inactive Vilsmeier or Rieche Reagent:** The formylating agent may have decomposed due to moisture or improper preparation.[\[5\]](#)
- **Insufficient Reaction Temperature:** The reaction may require more thermal energy to overcome the activation barrier.
- **Inappropriate Formylation Method:** The chosen method may not be suitable for your specific substituted pyridine.

Troubleshooting Steps:

Solution	Explanation	When to Use
Activate the Pyridine Ring	Convert the pyridine to its N-oxide. The N-oxide group is strongly electron-donating, activating the ring towards electrophilic attack, particularly at the C4 position.[3][6]	For pyridines with moderate to strong electron-withdrawing groups.
Use a More Reactive Formylation Method	For highly deactivated systems, consider a lithiation/formylation approach. This involves deprotonating the pyridine ring with a strong base followed by quenching with a formylating agent like DMF.[7][8]	When other methods fail and your substrate is compatible with strong bases.
Increase Reaction Temperature	Carefully increase the reaction temperature in increments while monitoring for product formation and decomposition.	For sluggish reactions where the substrate is thermally stable.
Ensure Anhydrous Conditions	Vilsmeier and Rieche reagents are highly sensitive to moisture. Ensure all glassware is oven-dried and solvents are anhydrous.	This is a critical parameter for all formylation reactions involving these reagents.
Use a Larger Excess of Formylating Agent	Increasing the concentration of the electrophile can sometimes drive the reaction forward.	For moderately deactivated substrates where a slight excess of reagent is not problematic for purification.

Problem 2: Poor Regioselectivity - Formylation at the Wrong Position

Q: I am getting a mixture of isomers, with the formyl group at an undesired position on the pyridine ring. How can I improve the regioselectivity?

A: Regioselectivity is governed by the electronic and steric effects of the substituents on the pyridine ring. Understanding these factors is key to controlling the position of formylation.

Controlling Factors:

- **Directing Effects of Substituents:** Electron-donating groups (EDGs) like -OR and -NR₂ typically direct ortho and para, while electron-withdrawing groups (EWGs) direct meta. However, in the pyridine ring, the situation is more complex due to the influence of the ring nitrogen.
- **Steric Hindrance:** Bulky substituents can block access to adjacent positions, favoring formylation at less hindered sites.
- **Reaction Mechanism:** Different formylation methods can lead to different regioselectivities.

Strategies for Controlling Regioselectivity:

Strategy	Description	Applicability
Directed ortho-Metalation (DoM)	A directing metalation group (DMG), such as an amide or a methoxy group, can direct a strong base to deprotonate the adjacent ortho position, which is then quenched with a formylating agent.[6]	For achieving substitution at a specific position adjacent to a directing group.
Blocking Groups	Introduce a temporary blocking group at a more reactive position to force formylation to occur at the desired, less reactive site. The blocking group can be removed in a subsequent step.	When a more reactive position needs to be temporarily deactivated.
Choice of Formylation Method	The Vilsmeier-Haack reaction on pyridine N-oxides strongly favors the 4-position. Lithiation can be directed to specific positions depending on the base and substituents.	To exploit the inherent regioselectivity of a particular reaction.
Temperature Control	Lowering the reaction temperature can sometimes favor the formation of the kinetically controlled product over the thermodynamically favored one, potentially improving selectivity.[9]	When a mixture of isomers is obtained at higher temperatures.

Illustrative Diagram: Influence of Substituents on Regioselectivity

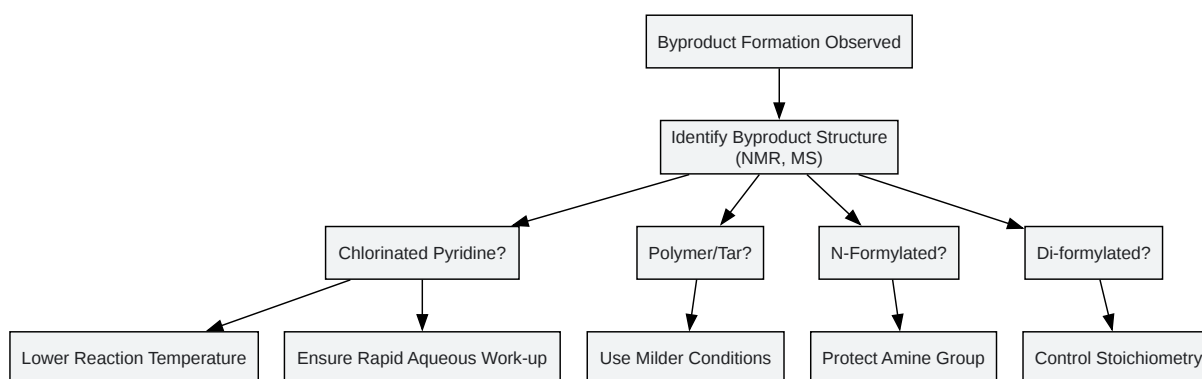
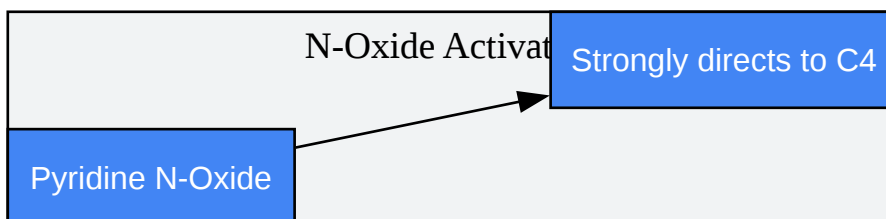
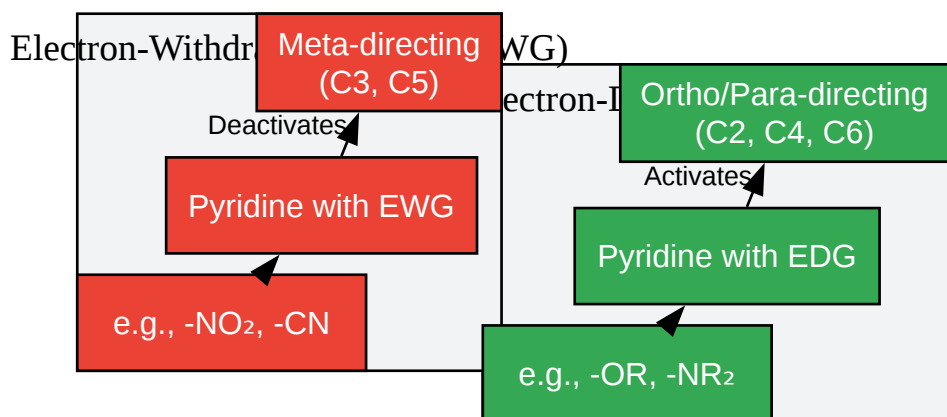

[Click to download full resolution via product page](#)

Need Custom Synthesis?

BenchChem offers custom synthesis for rare earth carbides and specific isotopic labeling.

Email: info@benchchem.com or [Request Quote Online](#).

Sources

- [1. pubs.acs.org](https://pubs.acs.org) [pubs.acs.org]
- [2. Vilsmeier-Haack Reaction - Chemistry Steps](https://chemistrysteps.com) [chemistrysteps.com]
- [3. benchchem.com](https://benchchem.com) [benchchem.com]
- [4. Electronic influence of substitution on the pyridine ring within NNN pincer-type molecules† - PMC](https://pubmed.ncbi.nlm.nih.gov/) [[pmc.ncbi.nlm.nih.gov](https://pubmed.ncbi.nlm.nih.gov/)]
- [5. pdf.benchchem.com](https://pdf.benchchem.com) [pdf.benchchem.com]
- [6. pdf.benchchem.com](https://pdf.benchchem.com) [pdf.benchchem.com]
- [7. triggered.stanford.clockss.org](https://triggered.stanford.clockss.org) [triggered.stanford.clockss.org]
- [8. Formylation - Common Conditions](https://commonorganicchemistry.com) [commonorganicchemistry.com]
- [9. pdf.benchchem.com](https://pdf.benchchem.com) [pdf.benchchem.com]
- To cite this document: BenchChem. [Technical Support Center: Formylation of Substituted Pyridines]. BenchChem, [2026]. [Online PDF]. Available at: [<https://www.benchchem.com/product/b1447602/docs#technical-support-center-formylation-of-substituted-pyridines>]

Disclaimer & Data Validity:

The information provided in this document is for Research Use Only (RUO) and is strictly not intended for diagnostic or therapeutic procedures. While BenchChem strives to provide accurate protocols, we make no warranties, express or implied, regarding the fitness of this product for every specific experimental setup.

Technical Support: The protocols provided are for reference purposes. Unsure if this reagent suits your experiment?

Need Industrial/Bulk Grade? [Request Custom Synthesis Quote](#)

BenchChem

Our mission is to be the trusted global source of essential and advanced chemicals, empowering scientists and researchers to drive progress in science and industry.

Contact

Address: 3281 E Guasti Rd

Ontario, CA 91761, United States

Phone: (601) 213-4426

Email: info@benchchem.com

[Contact our Ph.D. Support Team for a compatibility check](#)