

# A Comparative Guide to the Mass Spectrometry Fragmentation Patterns of Brominated Isoquinolinones

**Author:** BenchChem Technical Support Team. **Date:** May 2026

## Compound of Interest

**Compound Name:** 4-Bromo-5-methoxy-1,2-dihydroisoquinolin-1-one

**CAS No.:** 1207448-49-4

**Cat. No.:** B1447607

[Get Quote](#)

For Researchers, Scientists, and Drug Development Professionals

## Introduction: The Significance of Brominated Isoquinolinones and the Role of Mass Spectrometry

Brominated isoquinolinones represent a critical scaffold in medicinal chemistry and drug development, exhibiting a wide range of biological activities. The precise structural characterization of these molecules is paramount for understanding their structure-activity relationships (SAR) and for advancing lead optimization. Mass spectrometry (MS) stands as an indispensable analytical tool for this purpose, offering unparalleled sensitivity and structural information through the analysis of molecular fragmentation patterns.

This guide provides an in-depth, comparative analysis of the expected mass spectrometry fragmentation patterns of brominated isoquinolinones. In the absence of extensive, directly published data on this specific compound class, this guide synthesizes information from the

well-established fragmentation behaviors of the parent isoquinolinone core, various isoquinoline alkaloids, and other brominated aromatic compounds. We will explore the influence of different ionization techniques, delineate the key fragmentation pathways, and provide a robust framework for the structural elucidation of these important molecules.

## Pillar 1: Foundational Principles of Mass Spectrometry Fragmentation

The fragmentation of a molecule in a mass spectrometer is not a random process. When a molecule is ionized, it forms a molecular ion ( $M^{+\cdot}$ ) which is often energetically unstable. This excess energy can be dissipated through the cleavage of chemical bonds, resulting in the formation of smaller, charged fragment ions and neutral radical species. The fragmentation pathways are governed by the inherent stability of the resulting ions and radicals.

Two primary ionization techniques are commonly employed, each imparting a different amount of energy to the analyte and thus influencing the degree of fragmentation:

- Electron Ionization (EI): A "hard" ionization technique where high-energy electrons (typically 70 eV) bombard the analyte molecule.[1][2] This process imparts significant excess energy, leading to extensive and often complex fragmentation patterns.[2] These detailed fragmentation patterns can serve as a "fingerprint" for a specific molecule, which is invaluable for structural elucidation.[3]
- Electrospray Ionization (ESI): A "soft" ionization technique where ions are generated from a solution by creating a fine, charged aerosol.[4][5] ESI is significantly gentler than EI, typically resulting in minimal fragmentation and a prominent protonated molecule ( $[M+H]^+$ ) or deprotonated molecule ( $[M-H]^-$ ).[6][7] To induce fragmentation in ESI-MS, tandem mass spectrometry (MS/MS) is employed, where the precursor ion of interest is isolated and then fragmented through collision-induced dissociation (CID).

## Pillar 2: Deciphering the Fragmentation of the Isoquinolinone Core

The fragmentation of the isoquinolinone scaffold is influenced by the location of the carbonyl group and the presence of other substituents. Drawing parallels from the extensive studies on

isoquinoline alkaloids, we can predict the primary fragmentation pathways.

A systematic investigation into the fragmentation of 66 different isoquinoline alkaloids using ESI-Q-TOF/MS revealed that the fragmentation patterns are highly dependent on the structural type.<sup>[8][9][10]</sup> For isoquinolinone-type structures, key fragmentation events often involve:

- Loss of CO: A common fragmentation pathway for cyclic ketones and lactams, leading to a stable, ring-contracted ion.
- Retro-Diels-Alder (RDA) Reaction: If the isoquinolinone has a partially saturated ring, an RDA reaction can occur, cleaving the ring system and providing valuable structural information.
- Loss of Substituents: Functional groups on the isoquinolinone ring will fragment according to their own characteristic pathways. For example, methoxy groups can be lost as a methyl radical ( $\bullet\text{CH}_3$ ) or formaldehyde ( $\text{CH}_2\text{O}$ ).<sup>[8][9]</sup>

#### Visualizing Isoquinolinone Fragmentation

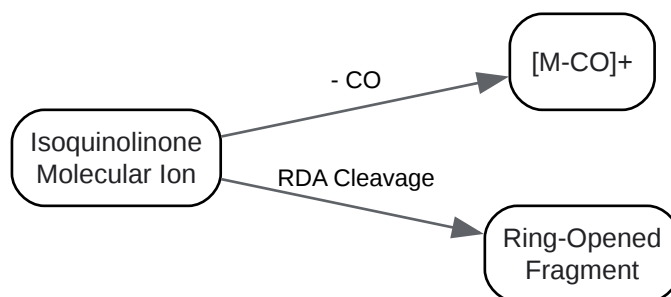

[Click to download full resolution via product page](#)

Caption: Predicted fragmentation pathways of the core isoquinolinone structure.

## Pillar 3: The Influence of Bromine on Fragmentation Patterns

The presence of a bromine atom introduces several characteristic features into the mass spectrum of an organic molecule.

## Isotopic Signature

Bromine has two stable isotopes,  $^{79}\text{Br}$  and  $^{81}\text{Br}$ , with near-equal natural abundance (approximately 50.7% and 49.3%, respectively). This results in a characteristic isotopic pattern for any bromine-containing ion, with two peaks of roughly equal intensity separated by two mass-to-charge units ( $m/z$ ). This "M/M+2" pattern is a definitive indicator of the presence of one bromine atom.

## Characteristic Cleavages

Under EI conditions, brominated aromatic compounds exhibit several key fragmentation pathways:

- Loss of a Bromine Radical ( $\text{Br}\cdot$ ): This is often a facile cleavage, leading to the formation of an  $[\text{M}-\text{Br}]^+$  ion. The stability of the resulting aryl cation influences the abundance of this fragment.
- Loss of HBr: This can occur through a rearrangement process, particularly if there is an adjacent hydrogen atom, resulting in an  $[\text{M}-\text{HBr}]^+$  ion.
- Formation of Bromide Anion ( $\text{Br}^-$ ): In negative chemical ionization (NCI) mode, many brominated aromatic compounds yield an intense bromide anion signal ( $m/z$  79 and 81).[\[11\]](#)  
This can be a highly sensitive method for the selective detection of brominated compounds.  
[\[11\]](#)[\[12\]](#)

Comparative Fragmentation of Brominated vs. Non-Brominated Isoquinolinones

Feature	Non-Brominated Isoquinolinone	Brominated Isoquinolinone	Rationale
Molecular Ion	Single $M^{+\cdot}$ peak	$M^{+\cdot}$ / $(M+2)^{+\cdot}$ doublet of ~1:1 intensity	Natural isotopic abundance of $^{79}\text{Br}$ and $^{81}\text{Br}$ .
Primary Neutral Loss	Loss of CO, H, or other substituents	Loss of $\text{Br}\cdot$ , HBr, or CO	The C-Br bond is relatively weak and its cleavage leads to a stable aryl cation.
Key Fragment Ions	$[\text{M}-\text{CO}]^+$ , RDA fragments	$[\text{M}-\text{Br}]^+$ , $[\text{M}-\text{HBr}]^{+\cdot}$ , $[\text{M}-\text{CO}-\text{Br}]^+$	The bromine atom introduces new, low-energy fragmentation channels.

### Visualizing the Impact of Bromination

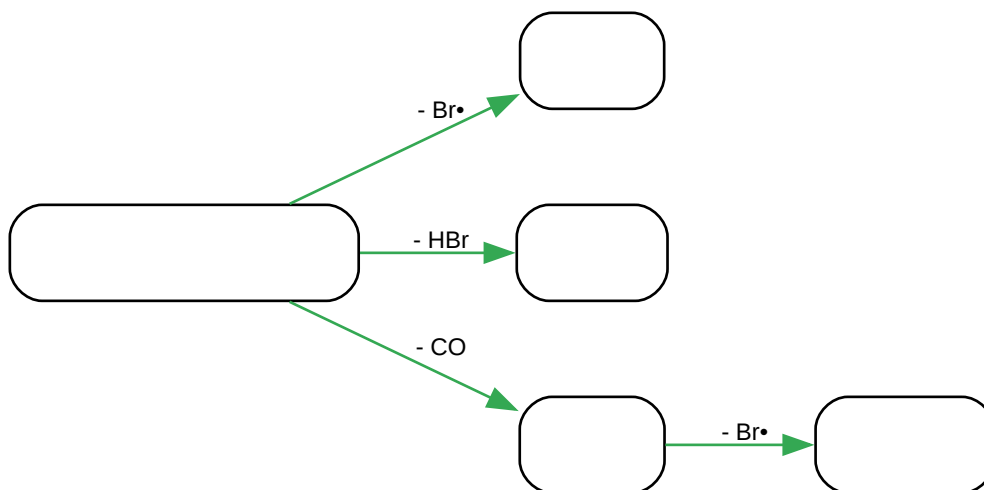

[Click to download full resolution via product page](#)

Caption: Key fragmentation pathways for a brominated isoquinolinone.

## Experimental Protocols: Acquiring High-Quality Mass Spectra

The following provides a generalized protocol for the analysis of brominated isoquinolinones. Instrument parameters should be optimized for the specific analyte and mass spectrometer used.

## Sample Preparation

- **Dissolution:** Dissolve approximately 1 mg/mL of the purified brominated isoquinolinone in a suitable volatile solvent (e.g., methanol, acetonitrile, or dichloromethane).
- **Filtration:** Filter the sample solution through a 0.22  $\mu\text{m}$  syringe filter to remove any particulate matter.

## Liquid Chromatography-Mass Spectrometry (LC-MS) for ESI Analysis

This is the preferred method for analyzing complex mixtures or for obtaining high-sensitivity data.

- **Chromatographic Column:** A C18 reversed-phase column is a good starting point (e.g., 2.1 mm x 50 mm, 1.8  $\mu\text{m}$  particle size).
- **Mobile Phase A:** 0.1% formic acid in water.
- **Mobile Phase B:** 0.1% formic acid in acetonitrile.
- **Gradient Program:** A typical gradient might start at 5% B, increasing to 95% B over 10 minutes, followed by a re-equilibration step.
- **Flow Rate:** 0.3 mL/min.
- **Column Temperature:** 40  $^{\circ}\text{C}$ .
- **Injection Volume:** 1-5  $\mu\text{L}$ .
- **Mass Spectrometry (ESI)**
  - **Ionization Mode:** Positive ion mode is generally preferred for nitrogen-containing compounds.

- Scan Mode:
  - Full Scan: To identify the precursor ion ( $[M+H]^+$ ).
  - Product Ion Scan (MS/MS): To obtain fragmentation data.
- Source Parameters:
  - Capillary Voltage: 3.5 - 4.5 kV.
  - Ion Source Temperature: 120 - 150 °C.
  - Desolvation Temperature: 350 - 450 °C.
  - Nebulizer Gas (Nitrogen) Flow: 8 - 12 L/hr.
- Collision Gas: Argon.
- Collision Energy: This is a critical parameter that needs to be optimized for each compound. A collision energy ramp (e.g., 10-40 eV) is often useful for initial screening.

## Direct Infusion or GC-MS for EI Analysis

For pure, volatile, and thermally stable compounds, EI can provide highly detailed fragmentation spectra.

- Inlet System: Direct insertion probe or Gas Chromatography (GC) interface.
- Ionization Energy: 70 eV.
- Source Temperature: 200 - 250 °C.
- Mass Range: Scan from  $m/z$  40 to a value approximately 50 Da above the molecular weight of the compound.

Visualizing the Analytical Workflow

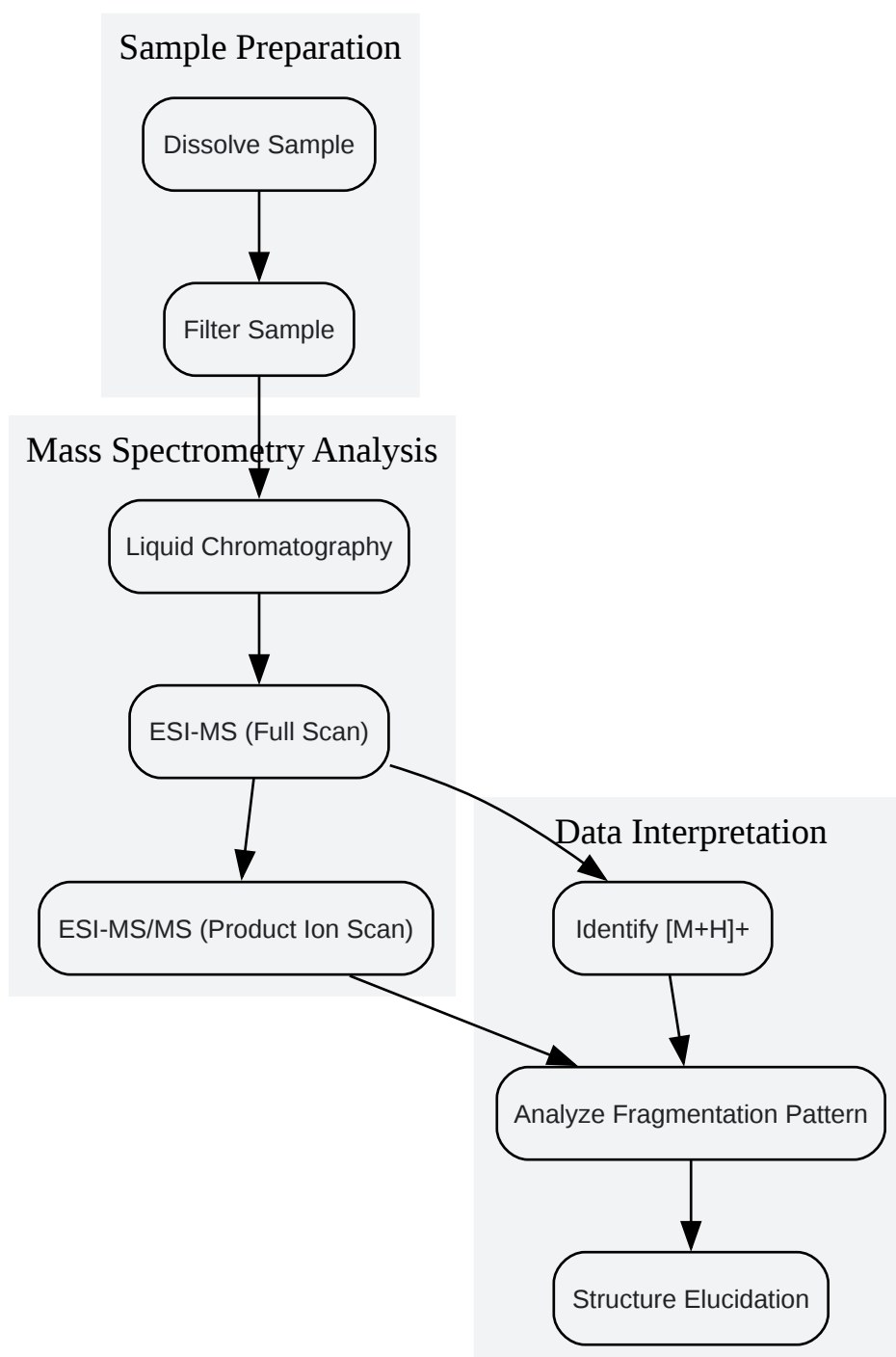

[Click to download full resolution via product page](#)

Caption: A typical workflow for the LC-MS/MS analysis of brominated isoquinolinones.

## Conclusion

The mass spectrometric analysis of brominated isoquinolinones provides a wealth of structural information that is critical for their role in drug discovery and development. While direct literature on this specific compound class is sparse, a comprehensive understanding of their fragmentation behavior can be achieved by synthesizing knowledge from the fragmentation of the core isoquinolinone structure and other brominated aromatic compounds.

By carefully selecting the ionization technique and optimizing instrument parameters, researchers can obtain high-quality mass spectra. The characteristic isotopic pattern of bromine, coupled with predictable fragmentation pathways such as the loss of Br•, HBr, and CO, provides a robust toolkit for the unambiguous structural elucidation of these important molecules. This guide serves as a foundational resource for scientists and researchers, enabling them to confidently apply mass spectrometry to accelerate their research in this promising area of medicinal chemistry.

## References

- Oehme, M. Selective detection of brominated aromatic compounds using gas chromatography/negative chemical ionization mass spectrometry. *Analytical Chemistry*. [\[Link\]](#)
- Chen, P., et al. (2020). Investigation of fragmentation behaviours of isoquinoline alkaloids by mass spectrometry combined with computational chemistry. *Scientific Reports*, 10(1), 875. [\[Link\]](#)
- Chen, P., et al. (2020). Investigation of fragmentation behaviours of isoquinoline alkaloids by mass spectrometry combined with computational chemistry. *ResearchGate*. [\[Link\]](#)
- Creaser, C. S., & Krokos, F. (1995). Quantitative Electrospray Mass Spectrometry of Halides and Halogenic Anions.
- Jakab, E., & Blazsó, M. (2006). Catalytic destruction of brominated aromatic compounds studied in a catalyst microbed coupled to gas chromatography/mass spectrometry. *Journal of Analytical and Applied Pyrolysis*, 77(2), 163-169.
- Popov, S. I., et al. (1996). Stereochemical effects in mass spectrometry: preferential formation of bromonium ions from trans-substituted 1,1',2,2'-polyalkyl-2,2'-dibromodiethyl ethers. *Journal of the Chemical Society, Perkin Transactions 2*, (1), 1-4.
- ResearchGate. Fragmentation pattern of isoquinoline (Scheme 3). [\[Link\]](#)

- Zwiener, C., & Glauner, T. (2007). Selective detection of unknown organic bromine compounds and quantification potentiality by negative-ion electrospray ionization mass spectrometry with induced in-source fragmentation. *International Journal of Environmental Analytical Chemistry*, 87(10-11), 737-746.
- Oehme, M. (1986). Selective detection of brominated aromatic compounds using gas chromatography/negative chemical ionization mass spectrometry. *Analytical chemistry*, 58(4), 785-789.
- Al-Shammary, F. J. (2018). Electron Ionization Mass Spectra of 2- and 4-Chloro- and Bromo-Substituted Diphenylamines. *Journal of Chemical and Pharmaceutical Research*, 10(8), 1-6.
- Wikipedia. Electrospray ionization. [[Link](#)]
- Chemguide. FRAGMENTATION PATTERNS IN THE MASS SPECTRA OF ORGANIC COMPOUNDS. [[Link](#)]
- Wikipedia. Electron ionization. [[Link](#)]
- Van den Bosch, S., et al. (2015). Mass Spectrometry-Based Fragmentation as an Identification Tool in Lignomics. *Analytical chemistry*, 87(15), 7945-7953.
- eGyanKosh. MASS SPECTROMETRY: FRAGMENTATION PATTERNS. [[Link](#)]
- Chen, P., et al. (2020). Investigation of fragmentation behaviours of isoquinoline alkaloids by mass spectrometry combined with computational chemistry. *PMC*. [[Link](#)]
- Chemistry LibreTexts. Electrospray Ionization Mass Spectrometry. [[Link](#)]
- Ghosh, C., & Pradeep, T. (2014). Electrospray Ionization Mass Spectrometry: A Technique to Access the Information beyond the Molecular Weight of the Analyte. *Journal of the Indian Institute of Science*, 94(2), 195-213.
- LabRulez. Electrospray Ionization (ESI) Explained | And why ESI is useful in Mass Spectrometry. [[Link](#)]
- LCGC International. Understanding Electron Ionization Processes for GC–MS. [[Link](#)]
- Research and Reviews. Investigation of Electron Ionization in Mass Spectrometry: Principles and Applications. [[Link](#)]

**Need Custom Synthesis?**

BenchChem offers custom synthesis for rare earth carbides and specific isotopic labeling.

Email: [info@benchchem.com](mailto:info@benchchem.com) or [Request Quote Online](#).

## Sources

- [1. Electron ionization - Wikipedia \[en.wikipedia.org\]](#)
- [2. chromatographyonline.com \[chromatographyonline.com\]](#)
- [3. rroj.com \[rroj.com\]](#)
- [4. Electrospray ionization - Wikipedia \[en.wikipedia.org\]](#)
- [5. youtube.com \[youtube.com\]](#)
- [6. chem.libretexts.org \[chem.libretexts.org\]](#)
- [7. Electrospray Ionization Mass Spectrometry: A Technique to Access the Information beyond the Molecular Weight of the Analyte - PMC \[pmc.ncbi.nlm.nih.gov\]](#)
- [8. Investigation of fragmentation behaviours of isoquinoline alkaloids by mass spectrometry combined with computational chemistry - PubMed \[pubmed.ncbi.nlm.nih.gov\]](#)
- [9. researchgate.net \[researchgate.net\]](#)
- [10. Investigation of fragmentation behaviours of isoquinoline alkaloids by mass spectrometry combined with computational chemistry - PMC \[pmc.ncbi.nlm.nih.gov\]](#)
- [11. pubs.acs.org \[pubs.acs.org\]](#)
- [12. pubs.acs.org \[pubs.acs.org\]](#)
- To cite this document: BenchChem. [A Comparative Guide to the Mass Spectrometry Fragmentation Patterns of Brominated Isoquinolinones]. BenchChem, [2026]. [Online PDF]. Available at: [<https://www.benchchem.com/product/b1447607/docs#a-comparative-guide-to-the-mass-spectrometry-fragmentation-patterns-of-brominated-isoquinolinones>]

---

**Disclaimer & Data Validity:**

The information provided in this document is for Research Use Only (RUO) and is strictly not intended for diagnostic or therapeutic procedures. While BenchChem strives to provide

accurate protocols, we make no warranties, express or implied, regarding the fitness of this product for every specific experimental setup.

**Technical Support:** The protocols provided are for reference purposes. Unsure if this reagent suits your experiment?

**Need Industrial/Bulk Grade?** [Request Custom Synthesis Quote](#)

## BenchChem

Our mission is to be the trusted global source of essential and advanced chemicals, empowering scientists and researchers to drive progress in science and industry.

### Contact

Address: 3281 E Guasti Rd

Ontario, CA 91761, United States

Phone: (601) 213-4426

Email: [info@benchchem.com](mailto:info@benchchem.com)

[Contact our Ph.D. Support Team for a compatibility check](#)