

# Flow Cytometry Analysis of Progranulin in Immune Cells: Application Notes and Protocols

**Author:** BenchChem Technical Support Team. **Date:** May 2026

## Compound of Interest

Compound Name:	Granulatin
CAS No.:	69306-81-6
Cat. No.:	B14456034

[Get Quote](#)

For Researchers, Scientists, and Drug Development Professionals

## Application Notes

### Introduction to Progranulin in Immunology

Progranulin (PGRN) is a secreted glycoprotein that plays a crucial role in various physiological processes, including cell growth, wound healing, and neuroinflammation.[1][2][3] In the immune system, progranulin is emerging as a key regulator of both innate and adaptive immunity.[4][5] It is expressed by a variety of immune cells, including microglia, macrophages, monocytes, and T cells.[1][2][5] Progranulin's immunomodulatory functions are complex, as it can exert both pro- and anti-inflammatory effects depending on the context and its cleavage into smaller granulin peptides.[4][6]

### Progranulin as a Biomarker and Therapeutic Target

The dysregulation of progranulin expression is implicated in a range of immune-mediated diseases. For instance, alterations in progranulin levels have been observed in conditions such as rheumatoid arthritis, inflammatory bowel disease, and neurodegenerative disorders with a

neuroinflammatory component.[4] This positions progranulin as a potential biomarker for disease activity and prognosis. Furthermore, its ability to modulate immune responses makes it an attractive therapeutic target for the development of novel drugs aimed at treating inflammatory and autoimmune diseases.[4][7]

## Flow Cytometry for Progranulin Analysis

Flow cytometry is a powerful technique for the quantitative analysis of intracellular proteins like progranulin at the single-cell level. This method allows for the precise measurement of progranulin expression within distinct immune cell subsets in a heterogeneous population, such as peripheral blood mononuclear cells (PBMCs) or brain-infiltrating leukocytes. By combining intracellular progranulin staining with cell surface markers, researchers can identify which specific immune cells express progranulin, quantify the expression levels, and correlate these findings with the activation state of the cells or the disease status.

## Quantitative Data on Progranulin Expression in Human Immune Cells

The following tables summarize the currently available qualitative and semi-quantitative data on progranulin expression in various human immune cell subsets. It is important to note that quantitative data such as Mean Fluorescence Intensity (MFI) is highly dependent on the specific antibody clone, fluorochrome, instrument settings, and experimental conditions. The data presented here is for informational purposes and should be confirmed by individual researchers.

Table 1: Progranulin Expression in Human Monocyte Subsets

Cell Type	Marker Profile	Progranulin Expression Level	Reference
Classical Monocytes	CD14++CD16-	High	[1][2]
Intermediate Monocytes	CD14++CD16+	Moderate to High	[1][2]
Non-Classical Monocytes	CD14+CD16++	Low to Moderate	[1][2]

Table 2: Progranulin Expression in Human T Lymphocyte Subsets

Cell Type	Marker Profile	Progranulin Expression Level	Reference
CD4+ T Helper Cells	CD3+CD4+	Low to Moderate	[5]
CD8+ Cytotoxic T Cells	CD3+CD8+	Low to Moderate	[5]
Regulatory T Cells (Tregs)	CD4+CD25+FoxP3+	Moderate	[8][9]

Table 3: Progranulin Expression in Human Microglia

Cell Type	Marker Profile	Progranulin Expression Level	Reference
Microglia	CD11b+CD45low	High	[10][11][12]

## Experimental Protocols

### Protocol 1: Intracellular Staining of Progranulin in Human PBMCs

This protocol describes the preparation and staining of human Peripheral Blood Mononuclear Cells (PBMCs) for the analysis of intracellular progranulin expression in monocytes and lymphocytes.

Materials:

- Human whole blood collected in EDTA or heparin tubes
- Ficoll-Paque PLUS (or similar density gradient medium)
- Phosphate-Buffered Saline (PBS)
- FACS Buffer (PBS + 2% FBS + 0.05% Sodium Azide)

- Cell surface antibodies (e.g., anti-CD3, anti-CD4, anti-CD8, anti-CD14, anti-CD16) conjugated to appropriate fluorochromes
- Fixation/Permeabilization Buffer Kit (e.g., from BioLegend, eBioscience, or BD Biosciences)
- Anti-human Progranulin (PGRN) antibody, validated for intracellular flow cytometry, conjugated to a suitable fluorochrome
- Isotype control antibody corresponding to the progranulin antibody
- Flow cytometer

#### Procedure:

- PBMC Isolation:
  1. Dilute whole blood 1:1 with PBS.
  2. Carefully layer the diluted blood over Ficoll-Paque in a conical tube.
  3. Centrifuge at 400 x g for 30 minutes at room temperature with the brake off.
  4. Carefully collect the buffy coat layer containing PBMCs.
  5. Wash the PBMCs twice with PBS by centrifugation at 300 x g for 10 minutes.
  6. Resuspend the cell pellet in FACS buffer and perform a cell count.
- Cell Surface Staining:
  1. Aliquot approximately  $1 \times 10^6$  cells per tube.
  2. Add the cocktail of cell surface antibodies at pre-titrated concentrations.
  3. Incubate for 20-30 minutes at 4°C in the dark.
  4. Wash the cells with 2 mL of FACS buffer and centrifuge at 300 x g for 5 minutes. Decant the supernatant.

- Fixation and Permeabilization:
  1. Resuspend the cell pellet in 100  $\mu$ L of Fixation Buffer.
  2. Incubate for 20 minutes at room temperature in the dark.
  3. Add 1 mL of Permeabilization Buffer and centrifuge at 350 x g for 5 minutes. Decant the supernatant.
  4. Wash the cells once with 1 mL of Permeabilization Buffer.
- Intracellular Staining:
  1. Resuspend the permeabilized cell pellet in 100  $\mu$ L of Permeabilization Buffer.
  2. Add the anti-human Progranulin antibody or the isotype control at the recommended concentration.
  3. Incubate for 30-45 minutes at room temperature in the dark.
  4. Wash the cells twice with 1 mL of Permeabilization Buffer.
- Acquisition:
  1. Resuspend the final cell pellet in 300-500  $\mu$ L of FACS Buffer.
  2. Acquire the samples on a flow cytometer. Be sure to set up appropriate compensation controls.

## Protocol 2: Intracellular Staining of Progranulin in Human Microglia

This protocol is for the analysis of progranulin in microglia isolated from human brain tissue.

Materials:

- Human brain tissue

- Enzymatic digestion solution (e.g., papain or collagenase/dispase)
- Debris removal solution (e.g., Percoll gradient)
- FACS Buffer
- Cell surface antibodies (e.g., anti-CD11b, anti-CD45)
- Fixation/Permeabilization Buffer Kit
- Anti-human Progranulin (PGRN) antibody, validated for intracellular flow cytometry
- Isotype control antibody
- Flow cytometer

#### Procedure:

- Microglia Isolation:
  1. Mechanically dissociate the brain tissue.
  2. Perform enzymatic digestion according to a validated protocol for microglia isolation.
  3. Remove myelin and debris using a Percoll gradient centrifugation.
  4. Collect the microglia-enriched cell population.
  5. Wash the cells with FACS buffer.
- Staining and Acquisition:
  1. Follow the same steps for Cell Surface Staining, Fixation and Permeabilization, Intracellular Staining, and Acquisition as described in Protocol 1, using microglia-specific surface markers.

## Visualizations

### Progranulin Signaling Pathways in Immune Cells

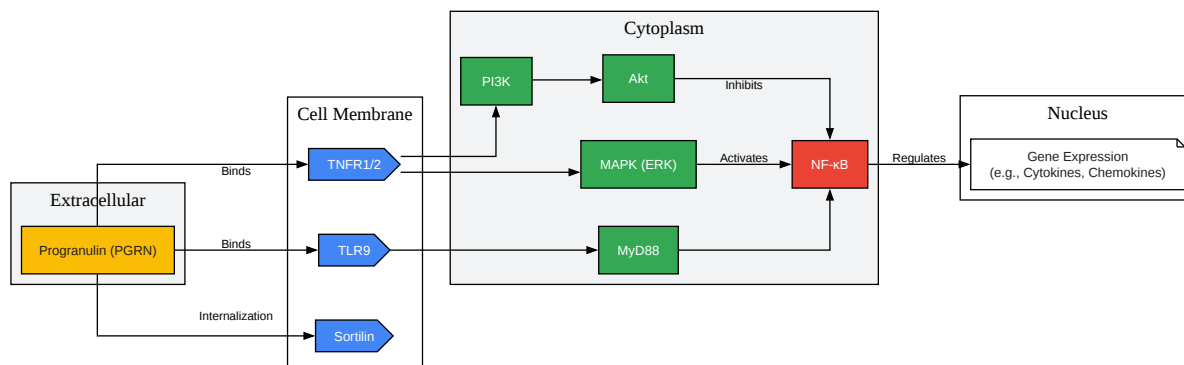

[Click to download full resolution via product page](#)

Caption: Progranulin signaling pathways in immune cells.

## Experimental Workflow for Flow Cytometry Analysis of Progranulin

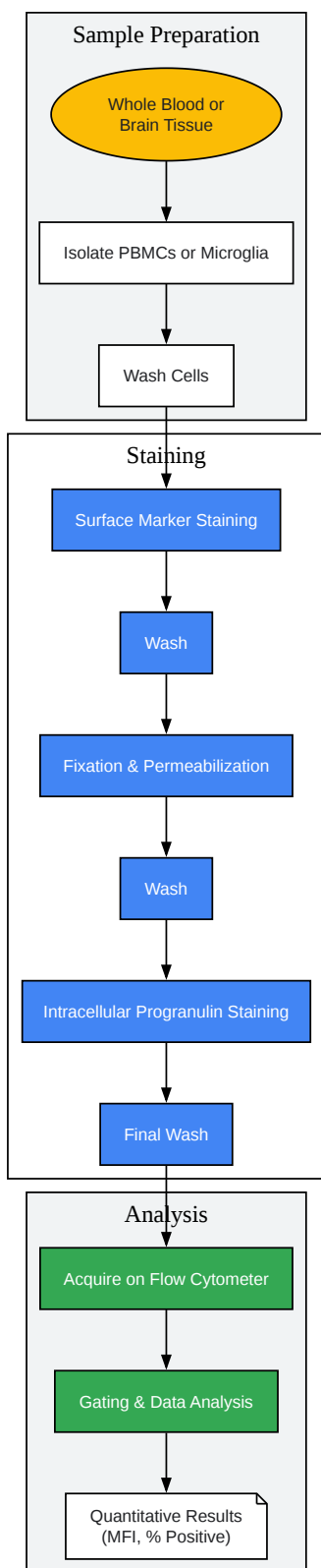

[Click to download full resolution via product page](#)

**Need Custom Synthesis?**

BenchChem offers custom synthesis for rare earth carbides and specific isotopic labeling.

Email: [info@benchchem.com](mailto:info@benchchem.com) or [Request Quote Online](#).

## References

- [1. journals.physiology.org \[journals.physiology.org\]](https://journals.physiology.org)
- [2. Regulation of progranulin expression in myeloid cells - PubMed \[pubmed.ncbi.nlm.nih.gov\]](#)
- [3. Progranulin inhibits LPS-induced macrophage M1 polarization via NF- \$\kappa\$ B and MAPK pathways - PubMed \[pubmed.ncbi.nlm.nih.gov\]](#)
- [4. Progranulin as a Potential Therapeutic Target in Immune-Mediated Diseases - PMC \[pmc.ncbi.nlm.nih.gov\]](#)
- [5. Insights into the role of progranulin in immunity, infection, and inflammation - PMC \[pmc.ncbi.nlm.nih.gov\]](#)
- [6. Progranulin inhibits LPS-induced macrophage M1 polarization via NF- \$\kappa\$ B and MAPK pathways - PMC \[pmc.ncbi.nlm.nih.gov\]](#)
- [7. Targeting Progranulin as an Immuno-Neurology Therapeutic Approach \[mdpi.com\]](#)
- [8. \[PDF\] Progranulin Facilitates Conversion and Function of Regulatory T Cells under Inflammatory Conditions | Semantic Scholar \[semanticscholar.org\]](#)
- [9. researchgate.net \[researchgate.net\]](#)
- [10. Regulation of progranulin expression in human microglia and proteolysis of progranulin by matrix metalloproteinase-12 \(MMP-12\) - PubMed \[pubmed.ncbi.nlm.nih.gov\]](#)
- [11. Progranulin Is a Chemoattractant for Microglia and Stimulates Their Endocytic Activity - PMC \[pmc.ncbi.nlm.nih.gov\]](#)
- [12. Regulation of Progranulin Expression in Human Microglia and Proteolysis of Progranulin by Matrix Metalloproteinase-12 \(MMP-12\) - PMC \[pmc.ncbi.nlm.nih.gov\]](#)
- To cite this document: BenchChem. [Flow Cytometry Analysis of Progranulin in Immune Cells: Application Notes and Protocols]. BenchChem, [2026]. [Online PDF]. Available at: [\[https://www.benchchem.com/product/b14456034/docs#flow-cytometry-analysis-of-progranulin-in-immune-cells-application-notes-and-protocols\]](https://www.benchchem.com/product/b14456034/docs#flow-cytometry-analysis-of-progranulin-in-immune-cells-application-notes-and-protocols)

---

**Disclaimer & Data Validity:**

The information provided in this document is for Research Use Only (RUO) and is strictly not intended for diagnostic or therapeutic procedures. While BenchChem strives to provide accurate protocols, we make no warranties, express or implied, regarding the fitness of this product for every specific experimental setup.

**Technical Support:** The protocols provided are for reference purposes. Unsure if this reagent suits your experiment?

**Need Industrial/Bulk Grade?** [Request Custom Synthesis Quote](#)

## BenchChem

Our mission is to be the trusted global source of essential and advanced chemicals, empowering scientists and researchers to drive progress in science and industry.

### Contact

Address: 3281 E Guasti Rd  
Ontario, CA 91761, United States  
Phone: (601) 213-4426  
Email: [info@benchchem.com](mailto:info@benchchem.com)

[Contact our Ph.D. Support Team for a compatibility check](#)