

The Indazole Scaffold: A Privileged Structure in Kinase Inhibition - A Comparative Guide

Author: BenchChem Technical Support Team. **Date:** May 2026

Compound of Interest

Compound Name: *5-Bromo-6-fluoro-3-methyl-1H-indazole*

CAS No.: 864773-66-0

Cat. No.: B1527767

[Get Quote](#)

The indazole core has solidified its position as a "privileged scaffold" in medicinal chemistry, particularly in the relentless pursuit of potent and selective protein kinase inhibitors.[1][2][3] Its versatile structure allows for strategic modifications, enabling the fine-tuning of inhibitory activity and selectivity against a wide array of kinases, which are critical regulators of cellular processes often dysregulated in diseases like cancer.[3][4] This guide provides an in-depth comparison of the kinase inhibitory activity of different indazole isomers, supported by experimental data, to empower researchers and drug development professionals in their quest for next-generation therapeutics.

Decoding the Structure-Activity Relationship: How Isomers Influence Potency

The specific arrangement of atoms within the indazole ring and the nature of its substituents are pivotal in determining the molecule's interaction with the ATP-binding pocket of a target kinase. Even subtle changes, such as the position of a substituent, can dramatically alter the inhibitory potency and selectivity profile of the compound. This structure-activity relationship (SAR) is a cornerstone of rational drug design in the field of kinase inhibition.[5][6]

For instance, substitutions at the 6-position of the indazole ring have been shown to be a critical determinant of both potency and selectivity against various kinases.[1] Similarly, the addition of different functional groups, such as amides or sulfonamides, can enhance binding affinity and introduce new interactions with the kinase domain.[5][7]

Comparative Analysis of Kinase Inhibitory Activity

The following table summarizes the in vitro kinase inhibitory activity of a series of indazole derivatives against various key kinases. The half-maximal inhibitory concentration (IC50) is a standard measure of a drug's effectiveness, with lower values indicating higher potency.

Compound ID/Name	Target Kinase(s)	IC50 (nM)	Key Structural Features/Isomer Information	Reference(s)
Axitinib	VEGFR-1, -2, -3	1.2, 0.2, 0.1-0.3	An indazole derivative, a potent second-generation inhibitor of Vascular Endothelial Growth Factor Receptors.	[2]
Pazopanib	VEGFR-1, -2, -3	10, 30, 47	An indazole-containing multi-kinase inhibitor.	[2]
Indazole Derivative 17	Aurora A, B	26, 15	A novel indazole derivative targeting Aurora kinases.	[8]
Indazole Amide 53a	Aurora A	< 1 μ M	An indazole amide derivative with activity against Aurora A.	[8]
Indazole-pyrimidine sulfonamide (13i)	VEGFR-2	34.5	A sulfonamide derivative of indazole targeting VEGFR-2.	[7]
Compound C05	PLK4	< 0.1	A novel indazole-based inhibitor of Polo-like Kinase 4 with exceptional potency.	[9]

3-ethynyl-1H-indazole 10	PI3K α	361	An ethynyl-substituted indazole that inhibits the PI3K signaling pathway.	[10]
Indazole amide derivative	ERK1/2	Potent inhibition	A series of indazole amides demonstrating potent inhibition of ERK1/2 enzyme activity.	[5]

Note: IC50 values can vary depending on the specific assay conditions. The data presented here is for comparative purposes.

The VEGFR Signaling Pathway and the Role of Indazole Inhibitors

Vascular Endothelial Growth Factor Receptors (VEGFRs) are key mediators of angiogenesis, the formation of new blood vessels, which is a critical process for tumor growth and metastasis. [2][8] Indazole-based inhibitors like Axitinib and Pazopanib have shown significant efficacy in targeting this pathway.

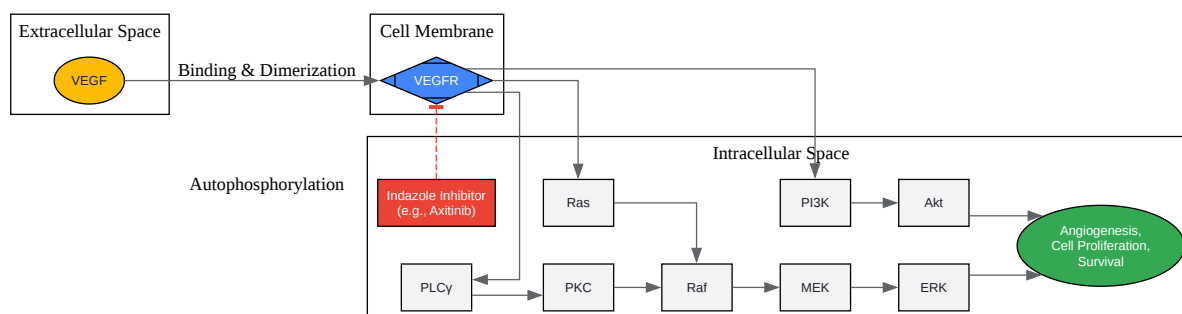

[Click to download full resolution via product page](#)

Caption: The VEGFR signaling pathway, a key target for indazole-based kinase inhibitors in cancer therapy.

Experimental Protocol: In Vitro Kinase Inhibition Assay (Luminescence-Based)

To quantitatively assess the inhibitory activity of different indazole isomers, a robust and reliable in vitro kinase assay is essential. The ADP-Glo™ Kinase Assay is a widely used luminescence-based method that measures the amount of ADP produced during a kinase reaction.

Principle: The assay is performed in two steps. First, after the kinase reaction, an ADP-Glo™ Reagent is added to terminate the kinase reaction and deplete the remaining ATP. Second, a Kinase Detection Reagent is added to convert ADP to ATP and then measure the newly synthesized ATP in a luciferase reaction that produces light. The amount of light generated is proportional to the ADP concentration, which directly correlates with kinase activity.

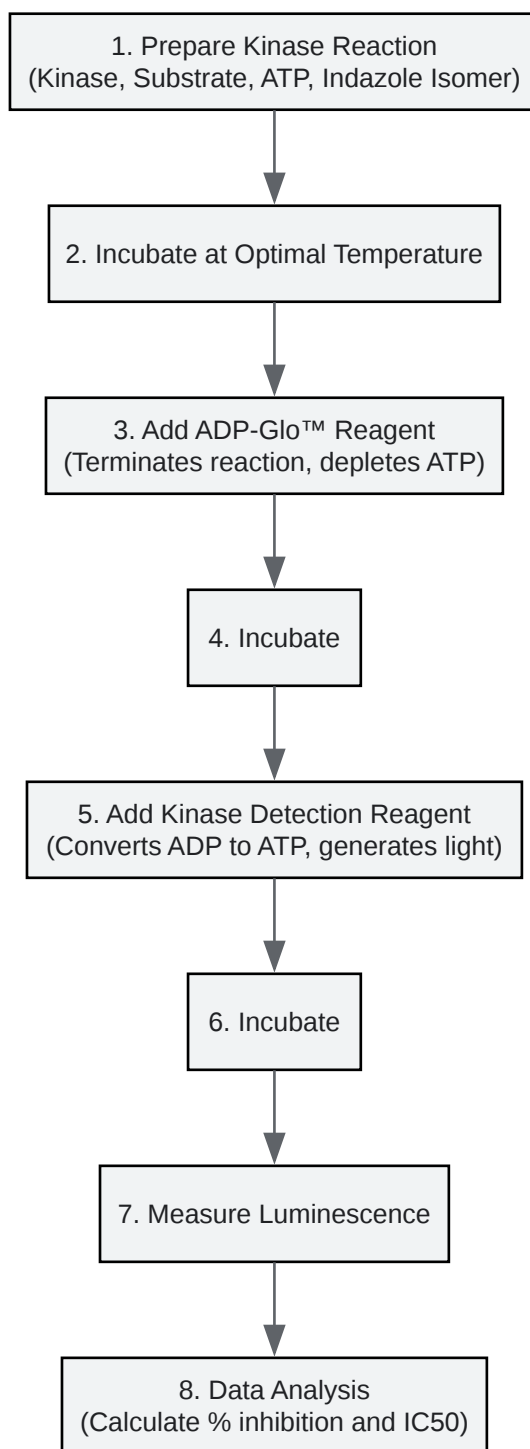

[Click to download full resolution via product page](#)

Caption: A generalized workflow for a luminescence-based in vitro kinase inhibition assay.

Step-by-Step Methodology:

- Prepare Reagents:
 - Prepare a stock solution of the indazole isomer in 100% DMSO.
 - Prepare serial dilutions of the indazole isomer in the appropriate kinase assay buffer. Ensure the final DMSO concentration in the assay is low (typically <1%) to avoid solvent-induced effects.
 - Prepare the kinase, substrate, and ATP solutions in the kinase assay buffer. The optimal concentrations of these components should be determined empirically.

- Kinase Reaction:
 - In a 96-well or 384-well white assay plate, add the serially diluted indazole isomers. Include appropriate controls: a "no inhibitor" control (vehicle, e.g., DMSO) and a "no kinase" control (background).
 - Add the kinase and substrate to all wells.
 - Initiate the kinase reaction by adding ATP.
 - Incubate the plate at the optimal temperature for the specific kinase (e.g., 30°C) for a predetermined amount of time.

- Signal Detection:
 - Add the ADP-Glo™ Reagent to all wells to stop the kinase reaction and deplete the remaining ATP.
 - Incubate the plate according to the manufacturer's instructions (e.g., 40 minutes at room temperature).
 - Add the Kinase Detection Reagent to all wells. This reagent will convert the ADP generated in the kinase reaction to ATP and then use this ATP in a coupled luciferase reaction to produce a luminescent signal.
 - Incubate the plate for a final period (e.g., 30-60 minutes at room temperature) to allow the luminescent signal to stabilize.

- Data Analysis:
 - Measure the luminescence using a plate-reading luminometer.
 - Subtract the background luminescence (from the "no kinase" control) from all other readings.
 - Calculate the percentage of kinase inhibition for each concentration of the indazole isomer relative to the "no inhibitor" control.
 - Plot the percentage of inhibition against the logarithm of the inhibitor concentration and fit the data to a dose-response curve to determine the IC50 value.

Trustworthiness and Self-Validating Systems

The reliability of the data generated from kinase inhibition assays is paramount. To ensure trustworthiness, the experimental design must incorporate a self-validating system. This includes:

- **Appropriate Controls:** The inclusion of positive (no inhibitor) and negative (no kinase) controls is essential for data normalization and background correction.
- **Dose-Response Curves:** Determining the full dose-response curve, rather than single-point inhibition, provides a more accurate and comprehensive understanding of the inhibitor's potency.
- **Orthogonal Assays:** Whenever possible, confirming the results with a different assay format (e.g., a fluorescence-based assay or a direct binding assay) can strengthen the conclusions.
- **Selectivity Profiling:** To understand the broader impact of an inhibitor, it should be screened against a panel of other kinases.^[11] This helps to identify potential off-target effects and provides a clearer picture of the compound's selectivity.

Conclusion and Future Directions

The indazole scaffold continues to be a fertile ground for the discovery of novel kinase inhibitors. The comparative analysis of different indazole isomers reveals the profound impact of subtle structural modifications on their inhibitory activity and selectivity. By leveraging a deep

understanding of SAR, employing robust experimental methodologies, and focusing on comprehensive selectivity profiling, researchers can continue to design and develop indazole-based kinase inhibitors with improved therapeutic profiles. The future of this field lies in the rational design of next-generation inhibitors that not only exhibit high potency against their intended targets but also possess a clean off-target profile, ultimately leading to safer and more effective treatments for a range of human diseases.

References

- Discovery and structure activity relationship study of novel indazole amide inhibitors for extracellular signal-regul
- A Comparative Analysis of Kinase Selectivity in 6-Substituted Indazole Deriv
- A Comparative Guide to Indazole-Derived Kinase Inhibitors: Efficacy and Selectivity Profile. Benchchem.
- Current progress, challenges and future prospects of indazoles as protein kinase inhibitors for the tre
- Current progress, challenges and future prospects of indazoles as protein kinase inhibitors for the tre
- Design, synthesis, and structure-activity relationships of 3-ethynyl-1H-indazoles as inhibitors of Phosphatidylinositol 3-kinase signaling p
- A Comparative Guide to the Structure-Activity Relationship of 6-Bromo-1-methyl-1H-indazol-4-amine Analogs as Kinase Inhibitors. Benchchem.
- Design, synthesis, and biological evaluation of indazole-based PLK4 inhibitors. PMC.
- Structures of kinase inhibitors containing an indazole moiety.
- Current progress, challenges and future prospects of indazoles as protein kinase inhibitors for the tre
- Discovery and optimization of indazoles as potent and selective interleukin-2 inducible T cell kinase (ITK) inhibitors. PubMed.
- Benchmarking new indazole derivatives against established kinase inhibitors. Benchchem.
- Addressing off-target effects of indazole-based kinase inhibitors. Benchchem.
- The Efficacy of Indazole Sulfonamides as Kinase Inhibitors: A Compar

Need Custom Synthesis?

BenchChem offers custom synthesis for rare earth carbides and specific isotopic labeling.

Email: info@benchchem.com or [Request Quote Online](#).

Sources

- [1. pdf.benchchem.com \[pdf.benchchem.com\]](#)
- [2. pdf.benchchem.com \[pdf.benchchem.com\]](#)
- [3. Current progress, challenges and future prospects of indazoles as protein kinase inhibitors for the treatment of cancer - RSC Advances \(RSC Publishing\) \[pubs.rsc.org\]](#)
- [4. Current progress, challenges and future prospects of indazoles as protein kinase inhibitors for the treatment of cancer - PMC \[pmc.ncbi.nlm.nih.gov\]](#)
- [5. Discovery and structure activity relationship study of novel indazole amide inhibitors for extracellular signal-regulated kinase1/2 \(ERK1/2\) - PubMed \[pubmed.ncbi.nlm.nih.gov\]](#)
- [6. pdf.benchchem.com \[pdf.benchchem.com\]](#)
- [7. pdf.benchchem.com \[pdf.benchchem.com\]](#)
- [8. pdf.benchchem.com \[pdf.benchchem.com\]](#)
- [9. Design, synthesis, and biological evaluation of indazole-based PLK4 inhibitors - PMC \[pmc.ncbi.nlm.nih.gov\]](#)
- [10. Design, synthesis, and structure-activity relationships of 3-ethynyl-1H-indazoles as inhibitors of Phosphatidylinositol 3-kinase signaling pathway - PMC \[pmc.ncbi.nlm.nih.gov\]](#)
- [11. pdf.benchchem.com \[pdf.benchchem.com\]](#)
- To cite this document: BenchChem. [The Indazole Scaffold: A Privileged Structure in Kinase Inhibition - A Comparative Guide]. BenchChem, [2026]. [Online PDF]. Available at: [<https://www.benchchem.com/product/b1527767/docs#the-indazole-scaffold-a-privileged-structure-in-kinase-inhibition-a-comparative-guide>]

Disclaimer & Data Validity:

The information provided in this document is for Research Use Only (RUO) and is strictly not intended for diagnostic or therapeutic procedures. While BenchChem strives to provide accurate protocols, we make no warranties, express or implied, regarding the fitness of this product for every specific experimental setup.

Technical Support: The protocols provided are for reference purposes. Unsure if this reagent suits your experiment?

Need Industrial/Bulk Grade? [Request Custom Synthesis Quote](#)

BenchChem

Our mission is to be the trusted global source of essential and advanced chemicals, empowering scientists and researchers to drive progress in science and industry.

Contact

Address: 3281 E Guasti Rd

Ontario, CA 91761, United States

Phone: (601) 213-4426

Email: info@benchchem.com

[Contact our Ph.D. Support Team for a compatibility check](#)