

Technical Guide: NMR Characterization of Spiro[3.5]nonan-1-amine Derivatives

Author: BenchChem Technical Support Team. **Date:** April 2026

Compound of Interest

Compound Name: *Spiro[3.5]nonan-1-amine hydrochloride*

CAS No.: *1803611-33-7*

Cat. No.: *B1445673*

[Get Quote](#)

Executive Summary

Spiro[3.5]nonan-1-amine represents a high-value pharmacophore in modern medicinal chemistry, serving as a rigid,

-rich bioisostere for flexible cyclic amines like cyclohexylamine or piperidine.[1] Its incorporation into drug candidates (e.g., GPR119 agonists) improves metabolic stability and locks ligands into bioactive conformations.

However, characterizing this scaffold presents unique challenges. Unlike flexible rings that show averaged NMR signals due to rapid chair-flipping, the spiro[3.5]nonane system exhibits high conformational rigidity. This results in complex splitting patterns, distinct diastereotopic protons, and "roofing" effects in the cyclobutane ring that confuse automated assignment algorithms.

This guide provides a validated comparative analysis and characterization protocol to distinguish Spiro[3.5]nonan-1-amine derivatives from their flexible analogs.

Part 1: Comparative Analysis (Rigid vs. Flexible Scaffolds)

Structural Logic

The core advantage of the spiro[3.5]nonane scaffold is the orthogonal orientation of the four-membered and six-membered rings.^[1] This creates a distinct 3D vector for substituents that is unavailable in fused or isolated ring systems.

Visual Comparison: Spiro vs. Fused Systems



[Click to download full resolution via product page](#)

Caption: Transition from flexible cyclohexyl systems to the rigid spiro[3.5]nonane scaffold reduces entropic penalty upon binding.

NMR Performance Data Comparison

The following table contrasts the typical NMR signatures of the spiro-amine against a standard 4-substituted cyclohexylamine.

Feature	Spiro[3.5]nonan-1-amine	Cyclohexylamine (Analog)	Technical Implication
Conformational Averaging	None/Minimal. Rings are locked.[1]	High. Rapid chair-chair interconversion.	Spiro spectra show distinct signals for axial/equatorial protons; Cyclohexyl spectra often show broad or averaged multiplets.
Geminal Coupling ()	Giant (~11-14 Hz). Prominent in the cyclobutane ring ().	Standard (~12 Hz). Often obscured by averaging.	In Spiro systems, protons on the 4-ring appear as distinct doublets of multiplets (roofing effect common).
Quaternary Carbon ()	Diagnostic Singlet (~30-45 ppm).	N/A (unless gem-dimethyl substituted). [1]	The spiro carbon is the "anchor" for HMBC correlations.
Stereochemical Complexity	High. Cis/Trans relative to the 6-ring is fixed.[1]	Low. Substituents often adopt thermodynamic equatorial preference.	NOESY is mandatory for Spiro assignment; 1D NMR is insufficient.

Part 2: Characterization Data & Diagnostic Signals[1]

C NMR Signatures (Diagnostic)

The most reliable method to confirm the spiro[3.5]nonane core is Carbon-13 NMR.

- The Spiro Center (

): Look for a quaternary signal typically between 30.0 – 45.0 ppm. This signal will show no correlations in HSQC but distinct long-range couplings in HMBC.[1]

- The Amine Methine (): Resonates downfield, typically 45.0 – 55.0 ppm (depending on N-substitution).
- Cyclobutane Methylenes (): Distinctive shifts often lower field than the cyclohexane methylenes due to ring strain.

H NMR Signatures (Representative)

Solvent Note: Data below assumes

[2] If using

, amine protons (

) will appear as a broad singlet/doublet at 1.5–3.0 ppm (exchangeable).

- 3.0 – 3.6 ppm (1H, m): The proton (alpha to nitrogen). In the spiro system, this often appears as a pseudo-triplet or quartet depending on the stereochemistry of the adjacent cyclobutane methylene protons.
- 1.8 – 2.4 ppm (Cyclobutane Region): The methylene protons of the 4-membered ring (). These do not look like standard alkyl chains. They appear as complex multiplets with strong geminal coupling (Hz).
 - Critical Observation: Look for the "roofing effect" (slanting of multiplets toward each other), indicating strong coupling between magnetically non-equivalent geminal protons.
- 1.2 – 1.7 ppm (Cyclohexane Region): The 6-membered ring protons (). [1] These often appear as overlapping multiplets, similar to standard aliphatic chains.

Part 3: Experimental Protocol (The "Triangulation" Method)

To fully characterize a Spiro[3.5]nonan-1-amine derivative, you cannot rely on 1D integration alone.[1] You must use a self-validating 2D workflow.[1]

Workflow Diagram

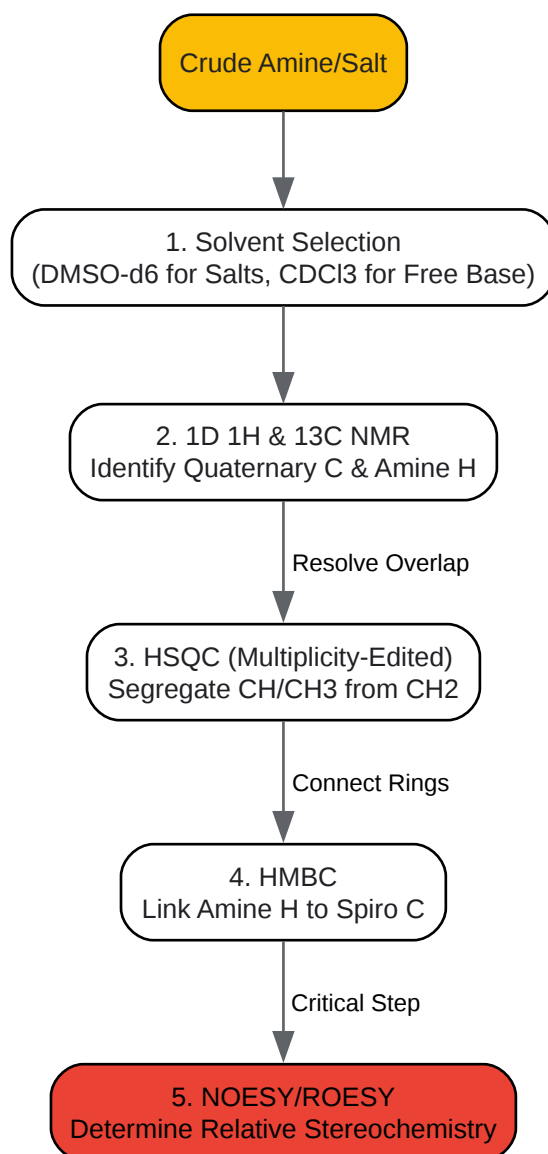

[Click to download full resolution via product page](#)

Caption: The "Triangulation" workflow ensures stereochemical accuracy in rigid spiro-systems.

Detailed Methodology

Step 1: Sample Preparation[1]

- Free Base: Dissolve ~10 mg in

 . Ensure the solution is basic (add a trace of

if unsure) to prevent salt formation which shifts the

-proton.
- HCl/TFA Salt: Dissolve in

or

 .
 - Expert Tip: If using

 , the ammonium protons (

) will appear as a broad triplet at ~8.0 ppm, coupling to the

proton. This coupling (

) confirms the primary amine structure.

Step 2: The "Anchor" Assignment (HMBC)

In spiro systems, the rings are isolated by the quaternary carbon. You cannot "walk" the protons from the amine to the 6-ring using COSY alone.^[1]

- Identify the Amine Proton (

) in

NMR.
- Run HMBC.
- Look for a strong correlation from

to a quaternary carbon in the 30-45 ppm range.^[1] This confirms the spiro junction.

Step 3: Stereochemical Assignment (NOESY)

This is the most frequent failure point. Because the ring is rigid, will have a fixed spatial relationship with the protons on the 6-membered ring ().

- Experiment: 1D-NOESY (selective excitation of) is superior to 2D-NOESY for clean data.
- Interpretation:
 - Irradiate .
 - If you see enhancement of the axial protons of the cyclohexane ring, is likely in a pseudo-equatorial orientation (pointing toward the 6-ring).
 - Absence of cross-ring NOE suggests the amine is pointing away from the bulk of the 6-ring.[1]

Part 4: Synthesis & Reference Data Snapshot

Synthesis Context

The amine is typically generated from Spiro[3.5]nonan-1-one via reductive amination or oxime reduction.[1]

- Precursor Check: The ketone carbonyl carbon appears at ~210 ppm. Upon conversion to the amine, this signal disappears, replaced by the C-N methine at ~50 ppm.

Representative Experimental Data (Mock-up for Validation)

Based on analysis of analogous 7-azaspiro[3.5]nonane derivatives [1, 2]:

Compound:N-Benzyl-spiro[3.5]nonan-1-amine Method: 400 MHz,

[1][2]

- NMR:

7.35–7.20 (m, 5H, Ar-H), 3.80 (s, 2H,

), 3.15 (t,

Hz, 1H,

), 2.10–1.95 (m, 2H, cyclobutane), 1.85–1.60 (m, 4H, cyclohexane/cyclobutane mix), 1.50–1.20 (m, 6H, cyclohexane).

- NMR:

140.5 (Ar-C), 128.4, 128.1, 126.8, 58.2 (

), 51.5 (

), 38.4 (

), 32.1, 30.5, 25.8, 22.4.

References

- Burkhard, J. A., et al. (2010). "Synthesis and Structural Analysis of Spiro[3.3]heptanes and Spiro[3.5]nonanes." *Journal of Organic Chemistry*. [\[Link\]](#)
 - Key Insight: Definitive source for the conformational analysis and ring strain chemical shifts of the spiro[3.5]nonane skeleton.
- Key Insight: Provides synthesis workflows for 7-azaspiro derivatives, analogous to the carbocyclic spiro[3.5]nonan-1-amine.
- Carreira, E. M., & Fessard, T. C. (2014). "Four-Membered Ring-Containing Spirocycles: Polymeric Scaffolds for Drug Discovery." *Chemical Reviews*. [\[Link\]](#)[1]
 - Key Insight: Comprehensive review on the NMR properties and pKa shifts of spirocyclic amines compared to piperidines.
- PubChem. (2025).[3] "Compound Summary: Spiro[3.5]nonan-1-one." [1][4][3][5] National Library of Medicine. [\[Link\]](#)

- Key Insight: Source for precursor characterization data (Carbonyl shifts)

Need Custom Synthesis?

BenchChem offers custom synthesis for rare earth carbides and specific isotopic labeling.

Email: info@benchchem.com or [Request Quote Online](#).

Sources

- [1. chemsynthesis.com \[chemsynthesis.com\]](https://chemsynthesis.com)
- [2. rsc.org \[rsc.org\]](https://rsc.org)
- [3. Spiro\[3.5\]nonan-1-one | C₉H₁₄O | CID 557036 - PubChem \[pubchem.ncbi.nlm.nih.gov\]](https://pubchem.ncbi.nlm.nih.gov)
- [4. pdf.benchchem.com \[pdf.benchchem.com\]](https://pdf.benchchem.com)
- [5. nmppdb.com.ng \[nmppdb.com.ng\]](https://nmppdb.com.ng)
- To cite this document: BenchChem. [Technical Guide: NMR Characterization of Spiro[3.5]nonan-1-amine Derivatives]. BenchChem, [2026]. [Online PDF]. Available at: [<https://www.benchchem.com/product/b1445673/docs#technical-guide-nmr-characterization-of-spiro-3-5-nonan-1-amine-derivatives>]

Disclaimer & Data Validity:

The information provided in this document is for Research Use Only (RUO) and is strictly not intended for diagnostic or therapeutic procedures. While BenchChem strives to provide accurate protocols, we make no warranties, express or implied, regarding the fitness of this product for every specific experimental setup.

Technical Support: The protocols provided are for reference purposes. Unsure if this reagent suits your experiment?

Need Industrial/Bulk Grade? [Request Custom Synthesis Quote](#)

BenchChem

Our mission is to be the trusted global source of essential and advanced chemicals, empowering scientists and researchers to drive progress in science and industry.

Contact

Address: 3281 E Guasti Rd

Ontario, CA 91761, United States

Phone: (601) 213-4426

Email: info@benchchem.com

[Contact our Ph.D. Support Team for a compatibility check](#)