

Technical Support Center: Minimizing Side Reactions During Piperazine Formylation

Author: BenchChem Technical Support Team. **Date:** April 2026

Compound of Interest

Compound Name: 2-(4-Formylpiperazin-1-yl)pyridine-3-carbonitrile
CAS No.: 1225710-24-6
Cat. No.: B1444055

[Get Quote](#)

Welcome to the technical support center for piperazine formylation. This guide is designed for researchers, scientists, and drug development professionals to navigate the complexities of selectively formylating piperazine while minimizing common side reactions. Here, we provide in-depth, field-proven insights and troubleshooting strategies in a direct question-and-answer format.

Section 1: Understanding the Core Reaction and Side Reactions

The N-formylation of piperazine is a fundamental transformation in organic synthesis, often serving as a gateway to more complex, pharmaceutically relevant molecules. The primary goal is typically to achieve mono-formylation, producing 1-formylpiperazine. However, the symmetrical nature of piperazine, with two reactive secondary amine groups, presents a significant challenge: the formation of the undesired 1,4-diformylpiperazine.^[1]

The core mechanism involves the nucleophilic attack of a piperazine nitrogen atom on the electrophilic carbon of a formylating agent, such as formic acid or ethyl formate.^{[2][3]}

Reaction Pathways

The competition between the desired mono-formylation and the undesired di-formylation is the central issue to control.

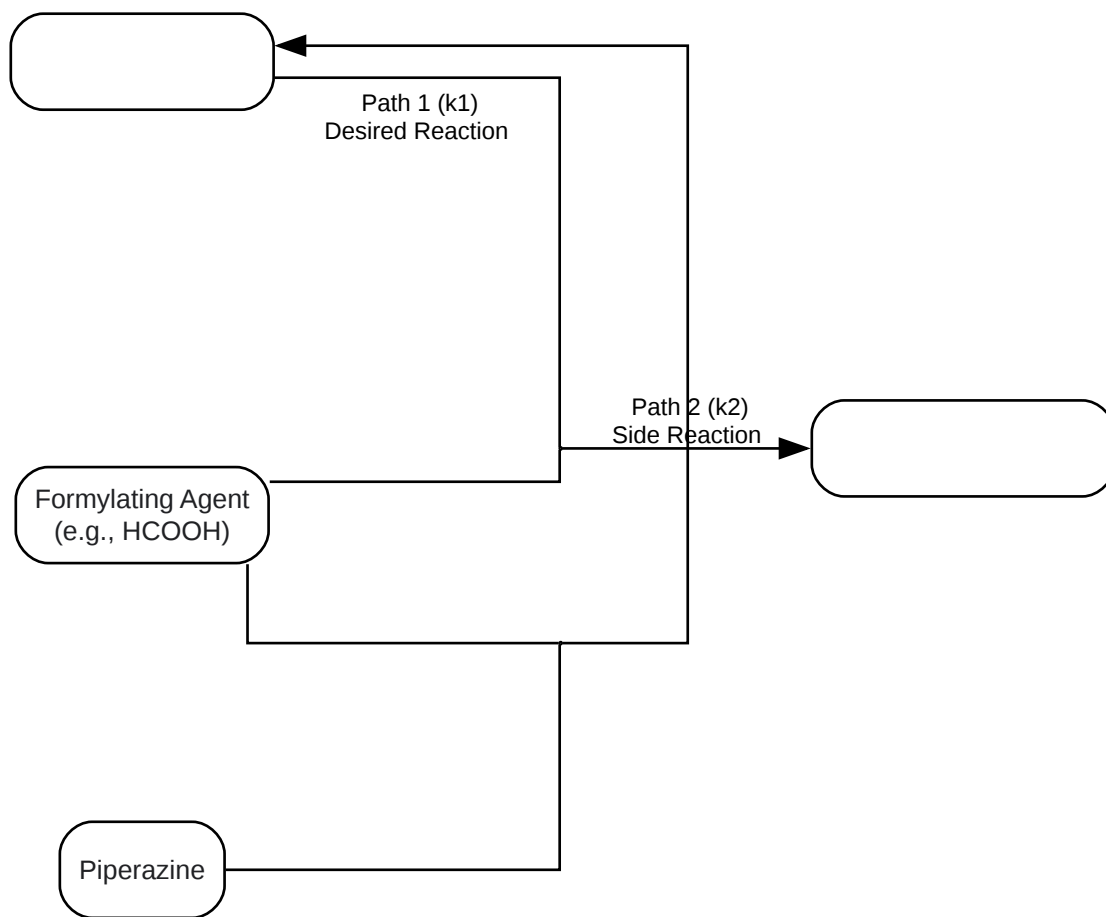

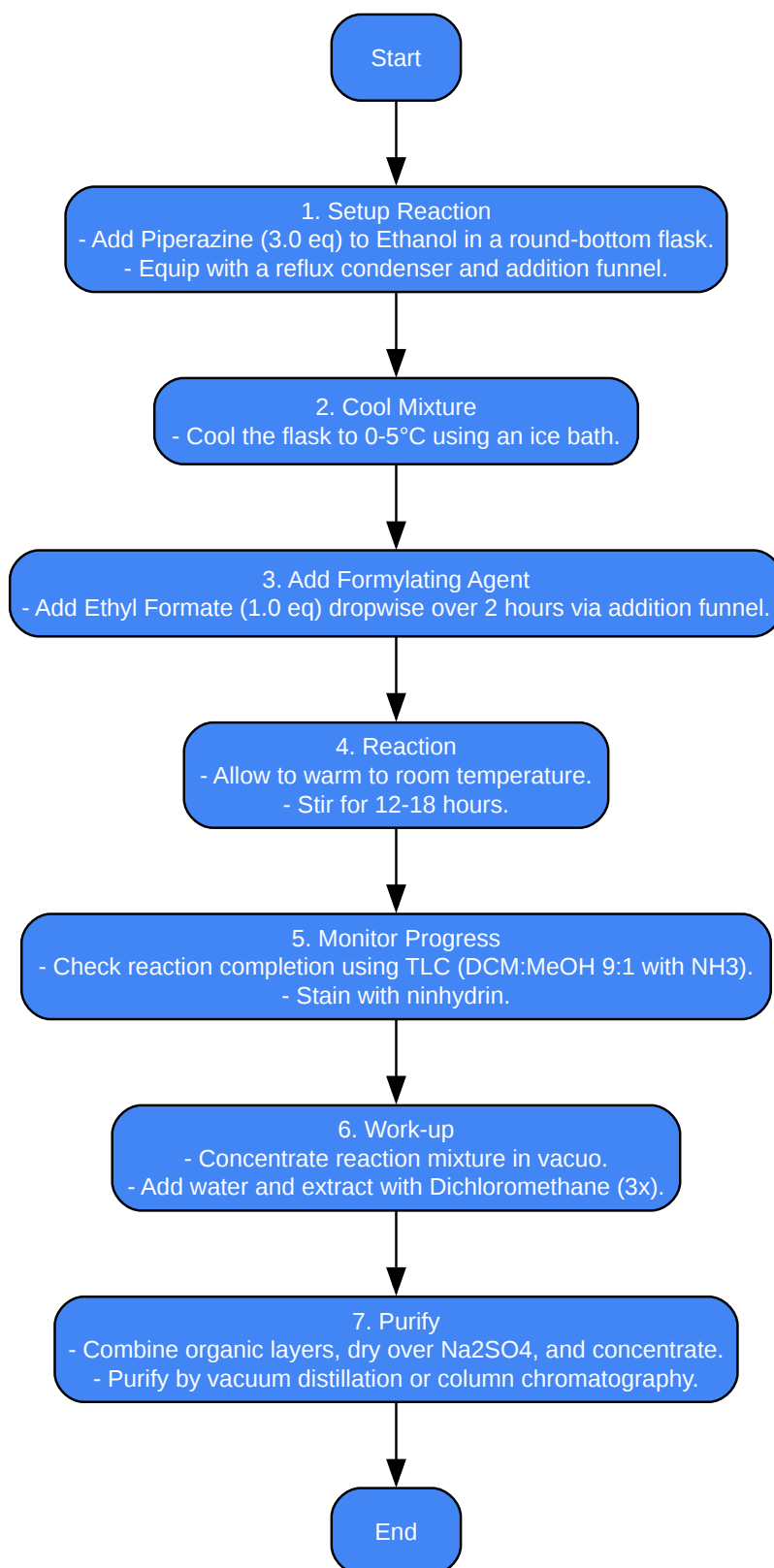

[Click to download full resolution via product page](#)

Need Custom Synthesis?

BenchChem offers custom synthesis for rare earth carbides and specific isotopic labeling.

Email: info@benchchem.com or [Request Quote Online](#).

Sources

- 1. pdf.benchchem.com [pdf.benchchem.com]
- 2. tandfonline.com [tandfonline.com]
- 3. researchgate.net [researchgate.net]
- To cite this document: BenchChem. [Technical Support Center: Minimizing Side Reactions During Piperazine Formylation]. BenchChem, [2026]. [Online PDF]. Available at: [<https://www.benchchem.com/product/b1444055/docs#technical-support-center-minimizing-side-reactions-during-piperazine-formylation>]

Disclaimer & Data Validity:

The information provided in this document is for Research Use Only (RUO) and is strictly not intended for diagnostic or therapeutic procedures. While BenchChem strives to provide accurate protocols, we make no warranties, express or implied, regarding the fitness of this product for every specific experimental setup.

Technical Support: The protocols provided are for reference purposes. Unsure if this reagent suits your experiment?

Need Industrial/Bulk Grade? [Request Custom Synthesis Quote](#)

BenchChem

Our mission is to be the trusted global source of essential and advanced chemicals, empowering scientists and researchers to drive progress in science and industry.

Contact

Address: 3281 E Guasti Rd
Ontario, CA 91761, United States
Phone: (601) 213-4426
Email: info@benchchem.com

Contact our Ph.D. Support Team for a compatibility check