

# Technical Support Center: Catalyst Poisoning in Cross-Coupling Reactions of Anilines

**Author:** BenchChem Technical Support Team. **Date:** May 2026

## Compound of Interest

Compound Name: *tert-Butyl (3-bromo-4-methylphenyl)carbamate*

CAS No.: 515813-02-2

Cat. No.: B1444340

[Get Quote](#)

Welcome to the Technical Support Center for troubleshooting catalyst poisoning in the cross-coupling reactions of anilines. This guide is designed for researchers, scientists, and professionals in drug development who encounter challenges with these sensitive yet powerful transformations. Here, we move beyond simple procedural lists to explore the underlying causes of common issues, providing you with the scientific rationale needed to make informed decisions in your experiments.

## Section 1: Frequently Asked Questions (FAQs) - The First Line of Defense

This section addresses the most common initial questions and problems encountered during aniline cross-coupling reactions, particularly the Buchwald-Hartwig amination.

**Q1: My reaction has stalled or shows low conversion. How do I know if catalyst poisoning is the culprit?**

A: Distinguishing catalyst poisoning from other issues like poor reagent quality or suboptimal conditions is a critical first step. Catalyst poisoning often manifests as a reaction that starts but then abruptly stops, or proceeds to a consistent but low conversion, even with extended reaction times.

A key diagnostic experiment is to add a fresh charge of catalyst and ligand to the stalled reaction mixture. If the reaction restarts and proceeds further, it strongly suggests that the initial catalyst was deactivated or "poisoned" by a component in the reaction. If there is no change, the issue may lie with the intrinsic reactivity of your substrates or other reaction parameters.

## Q2: What are the most common catalyst poisons I should be aware of?

A: Palladium catalysts, the workhorses of C-N cross-coupling, are susceptible to a range of substances that can irreversibly bind to the metal center, blocking active sites. Be vigilant for the following culprits:

- **Sulfur Compounds:** Thiols, thioethers (methylsulfanyl groups), and sulfoxides are notorious poisons for palladium catalysts.<sup>[1][2]</sup> Even trace amounts from starting materials or solvents can be detrimental.
- **Coordinating Functional Groups:** Unprotected functional groups on your aniline or aryl halide can act as competitive ligands, sequestering the palladium. Common examples include nitriles, nitro compounds, oximes, and certain nitrogen-containing heterocycles like pyridines and quinolines.<sup>[3][4]</sup>
- **Excess Cyanide, Halides, and Phosphates:** These ions can strongly coordinate to the palladium center, leading to the formation of inactive catalyst species.<sup>[3][5]</sup>
- **Oxygen:** While many modern precatalysts offer some air stability, the active Pd(0) species is sensitive to oxidation. Inadequate degassing or a poor inert atmosphere can lead to catalyst deactivation.<sup>[6]</sup>
- **Water and Other Protic Impurities:** While some Buchwald-Hartwig protocols tolerate or even benefit from small amounts of water, excess water can interfere with the base or promote catalyst decomposition pathways.<sup>[7]</sup>

### **Q3: My aniline substrate is from a commercial source and has high purity by NMR. Could it still contain catalyst poisons?**

A: Absolutely. Standard analytical techniques like NMR or LC-MS are excellent for identifying major components but may not detect trace impurities that are potent catalyst poisons. Anilines, in particular, can contain residual impurities from their synthesis, such as sulfur-containing reagents or byproducts with strongly coordinating functional groups. It is often best practice to purify commercial anilines before use, for example, by distillation, recrystallization, or filtration through a plug of activated alumina.[8]

### **Q4: I'm using an aniline with an electron-withdrawing group and getting low yields. Is this poisoning or just low reactivity?**

A: This is a common point of confusion. Electron-deficient anilines are inherently less nucleophilic, which slows down the C-N bond-forming step of the catalytic cycle.[6] This reduced reactivity can sometimes be mistaken for catalyst poisoning. However, these anilines can also be more prone to containing impurities that act as poisons.

To differentiate, consider the reaction profile. If the reaction proceeds slowly but steadily to a reasonable conversion over a longer time or at higher temperatures, the issue is likely low reactivity. If the reaction stops prematurely, poisoning is a more probable cause. For electron-deficient anilines, using a well-defined, air-stable precatalyst and ensuring a rigorously inert atmosphere are critical to rule out catalyst deactivation.[6]

## **Section 2: Troubleshooting Guide - A Deeper Dive**

When the initial FAQs don't solve the problem, a more systematic approach is needed. This guide provides a logical workflow to diagnose and resolve persistent issues related to catalyst poisoning.

### **Issue 1: Consistently Low or No Conversion**

If your reaction consistently fails or gives minimal product, follow this troubleshooting tree.

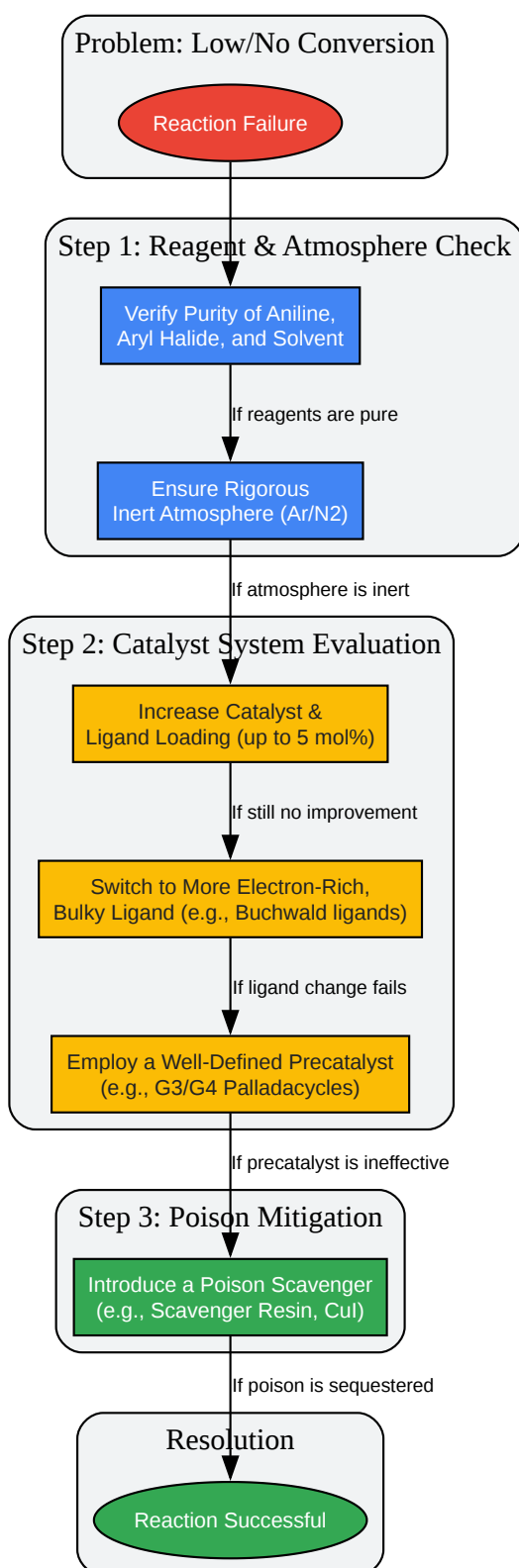

[Click to download full resolution via product page](#)

Caption: A logical workflow for troubleshooting low conversion in aniline cross-coupling.

## Causality Behind the Steps:

- **Reagent Purity & Inert Atmosphere:** This is the foundation. Impure reagents are a primary source of poisons.[8] Oxygen can deactivate the sensitive Pd(0) catalytic species.[6]
- **Increase Catalyst Loading:** If a poison is present at a low level, a higher catalyst concentration may overcome the stoichiometric deactivation, allowing the reaction to proceed. This is a diagnostic tool as much as a solution.[2]
- **Switch Ligand:** Electron-rich, sterically bulky phosphine ligands (like the Buchwald-type ligands) are designed to promote the desired catalytic cycle steps (oxidative addition and reductive elimination) and can form more stable, resilient palladium complexes that are less susceptible to displacement by poisoning species.[9][10]
- **Use a Precatalyst:** Traditional palladium sources like Pd(OAc)<sub>2</sub> or Pd<sub>2</sub>(dba)<sub>3</sub> require in-situ reduction to the active Pd(0) species. This activation step can be inefficient and is sensitive to impurities. Well-defined precatalysts (e.g., Buchwald G3 or G4 palladacycles) generate the active L-Pd(0) species more cleanly and reliably, improving consistency.[8]
- **Add a Poison Scavenger:** If poisoning is strongly suspected, a scavenger can be added to the reaction mixture to bind the poison before it reaches the palladium catalyst.

## Issue 2: My Aniline Contains a Known Poisoning Group (e.g., Thioether)

For substrates containing functionalities known to be catalyst poisons, a proactive approach is required.

### Mitigation Strategies for Known Poisons:

| Strategy                              | Mechanism of Action   | When to Use   | Key Considerations   |
|---------------------------------------|---|---|--|
| Increase Catalyst Loading             | Stoichiometrically overcomes the poison by providing excess active catalyst.  | For substrates with weakly coordinating poisons or when other methods are not feasible.   | Can be costly and lead to higher residual palladium in the product. A loading of 2-5 mol% is a typical starting point. <a href="#">[2]</a> |
| Use Specialized Ligands               | Highly electron-rich and sterically bulky ligands can form more stable catalyst complexes that are less prone to deactivation.  | This is often the most effective first-line strategy for challenging substrates.  | Ligands like BrettPhos and other advanced biarylphosphines are designed for this purpose. <a href="#">[7]</a> <a href="#">[11]</a>         |
| Employ Scavenger Resins               | Polymer-supported reagents (e.g., with copper or other metals) that selectively bind and remove sulfur-containing impurities from starting materials before the reaction. | As a pre-treatment step for aniline or solvent purification when high levels of sulfur contamination are suspected.                       | Requires an additional filtration step. Ensure the resin itself does not introduce new contaminants.                                       |
| Additive-Based Scavenging (e.g., CuI) | Copper(I) salts can act as sacrificial agents, preferentially binding to sulfur compounds and protecting the palladium catalyst.  | Can be added directly to the reaction mixture. Particularly useful for Stille couplings involving anilino-stannanes. <a href="#">[12]</a> | May require re-optimization of reaction conditions as the additive can affect the primary catalytic cycle.                                 |

## Section 3: Experimental Protocols

## Protocol 1: Purification of Anilines via Alumina Plug Filtration

This protocol is effective for removing polar impurities and potential poisons from liquid aniline starting materials.

- Preparation: Take a Pasteur pipette and plug it with a small amount of glass wool.
- Packing: Add a 2-3 cm layer of activated alumina to the pipette.
- Elution: Carefully apply the liquid aniline to the top of the alumina plug.
- Collection: Using gentle pressure from a pipette bulb, push the aniline through the alumina and collect the purified liquid in a clean, dry, inert-atmosphere flask.
- Storage: The purified aniline should be used immediately or stored under an inert atmosphere.<sup>[8]</sup>

## Protocol 2: General Procedure for a Robust Buchwald-Hartwig Amination

This protocol incorporates best practices to minimize the risk of catalyst deactivation.

- Vessel Preparation: In a glovebox or under a strong flow of inert gas, add the aryl halide (1.0 mmol), the aniline (1.2 mmol), and a strong, non-nucleophilic base (e.g., NaOt-Bu or K<sub>3</sub>PO<sub>4</sub>, 1.4 mmol) to an oven-dried reaction vial equipped with a stir bar.
- Catalyst Addition: Add the palladium precatalyst (e.g., a G3-Palladacycle, 0.01-0.02 mmol, 1-2 mol%) and the appropriate ligand (if not using a precatalyst that includes it).
- Solvent Addition: Add degassed, anhydrous solvent (e.g., toluene or dioxane, 2-3 mL).
- Reaction: Seal the vial and place it in a preheated oil bath or heating block at the desired temperature (typically 80-110 °C).
- Monitoring: Stir the reaction vigorously and monitor its progress by TLC or LC-MS.

- Workup: Upon completion, cool the reaction to room temperature, dilute with a suitable solvent like ethyl acetate, and filter through a pad of Celite to remove palladium black and inorganic salts.[6]

## Section 4: Mechanistic Insights - Understanding the "Why"

A deeper understanding of the poisoning mechanism allows for more effective troubleshooting.

### The Mechanism of Catalyst Poisoning

Catalyst poisoning in palladium-catalyzed cross-couplings typically occurs through strong coordination of an impurity to the palladium center. This can happen at various stages of the catalytic cycle.

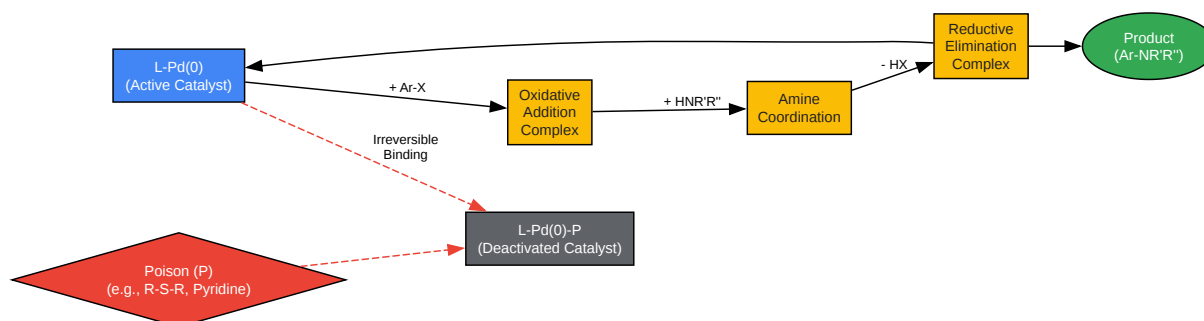

[Click to download full resolution via product page](#)

Caption: The catalytic cycle of Buchwald-Hartwig amination and the intervention of a poisoning species.

As illustrated, a poison (P) can coordinate so strongly to the active Pd(0) species that it effectively removes it from the catalytic cycle, forming a stable, inactive complex.[13][14] This binding is often irreversible under the reaction conditions, leading to a complete cessation of

catalytic activity. The key to preventing this is to either remove the poison beforehand or to use a catalyst system that is less susceptible to this deactivation pathway.

## References

- Catalyst poisoning - Wikipedia. (URL: [\[Link\]](#))
- Catalyst Poisoning: Palladium & Platinum | StudySmarter. (URL: [\[Link\]](#))
- Catalyst poisoning - chemeurope.com. (URL: [\[Link\]](#))
- How to Prevent Catalyst Poisoning at the Industrial Scale. (URL: [\[Link\]](#))
- Mechanistic and Performance Studies on the Ligand-Promoted Ullmann Amination Reaction | ACS Catalysis - ACS Publications. (URL: [\[Link\]](#))
- Photoelectrochemical Ni-catalyzed cross-coupling of aryl bromides with amine at ultra-low potential - NIH. (URL: [\[Link\]](#))
- Development of an Aryl Amination Catalyst with Broad Scope Guided by Consideration of Catalyst Stability - DSpace@MIT. (URL: [\[Link\]](#))
- Poisoning and deactivation of palladium catalysts | Request PDF - ResearchGate. (URL: [\[Link\]](#))
- Cross-coupling reactions with nickel, visible light, and tert-butylamine as a bifunctional additive | ChemRxiv. (URL: [\[Link\]](#))
- Buchwald–Hartwig amination - Wikipedia. (URL: [\[Link\]](#))
- Enabling Room-Temperature Copper Cross-Coupling Reactions of Anilines with Aryl Bromides - ChemRxiv. (URL: [\[Link\]](#))
- Development of a Ligand for Cu-Catalyzed Amination of Base-Sensitive (Hetero)aryl Chlorides - PMC - PubMed Central. (URL: [\[Link\]](#))
- Role of the Base in Buchwald–Hartwig Amination - OUCI. (URL: [\[Link\]](#))

- Buchwald-Hartwig Amination - Chemistry LibreTexts. (URL: [\[Link\]](#))
- Amines as Activating Ligands for Phosphine Palladium(II) Precatalysts: Effect of Amine Ligand Identity on the Catalyst Efficiency | Request PDF - ResearchGate. (URL: [\[Link\]](#))
- o-(Trialkylstannyl)anilines and Their Utility in Stille Cross-Coupling: Direct Introduction of the 2-Aminophenyl Substituent - NIH. (URL: [\[Link\]](#))
- Advanced Strategies for Mitigating Catalyst Poisoning in Low and High Temperature Proton Exchange Membrane Fuel Cells: Recent Progress and Perspectives - MDPI. (URL: [\[Link\]](#))
- The first Pd-catalyzed Buchwald–Hartwig aminations at C-2 or C-4 in the estrone series. (URL: [\[Link\]](#))
- Bypassing the Limitations of Directed C–H Functionalizations of Heterocycles - PMC - NIH. (URL: [\[Link\]](#))
- Advanced Strategies for Mitigating Catalyst Poisoning in Low and High Temperature Proton Exchange Membrane Fuel Cells: Recent Progress and Perspectives - ResearchGate. (URL: [\[Link\]](#))
- Rational Ligand Design for the Arylation of Hindered Primary Amines Guided by Reaction Progress Kinetic Analysis | Journal of the American Chemical Society. (URL: [\[Link\]](#))
- Room-Temperature Copper Cross-Coupling Reactions of Anilines with Aryl Bromides.. (URL: [\[Link\]](#))
- Mechanisms of Catalyst Poisoning in Palladium-Catalyzed Cyanation of Haloarenes. Remarkably Facile C–N Bond Activation in the [(Ph<sub>3</sub>P)<sub>4</sub>Pd]/[Bu<sub>4</sub>N] + CN - System | Request PDF - ResearchGate. (URL: [\[Link\]](#))
- Chapter 3: Synthetic Methods for Primary Anilines - Books. (URL: [\[Link\]](#))
- Amine might end palladium's reign over classic cross coupling reaction - Chemistry World. (URL: [\[Link\]](#))

- Cross-coupling strategies for aniline synthesis a, Anilines are... - ResearchGate. (URL: [\[Link\]](#))
- Mechanochemical Buchwald–Hartwig Cross-Coupling Reactions of Aromatic Primary Amines and Their Application to Two-Step One-Pot Rapid Synthesis of Unsymmetrical Triarylamines - ACS Publications. (URL: [\[Link\]](#))

### Need Custom Synthesis?

BenchChem offers custom synthesis for rare earth carbides and specific isotopic labeling.

Email: [info@benchchem.com](mailto:info@benchchem.com) or [Request Quote Online](#).

## Sources

- [1. pdf.benchchem.com \[pdf.benchchem.com\]](#)
- [2. pdf.benchchem.com \[pdf.benchchem.com\]](#)
- [3. Catalyst poisoning - Wikipedia \[en.wikipedia.org\]](#)
- [4. Catalyst\\_poisoning \[chemeurope.com\]](#)
- [5. researchgate.net \[researchgate.net\]](#)
- [6. pdf.benchchem.com \[pdf.benchchem.com\]](#)
- [7. chem.libretexts.org \[chem.libretexts.org\]](#)
- [8. sigmaaldrich.cn \[sigmaaldrich.cn\]](#)
- [9. dspace.mit.edu \[dspace.mit.edu\]](#)
- [10. Catalysts and Ligands - Enamine \[enamine.net\]](#)
- [11. pubs.acs.org \[pubs.acs.org\]](#)
- [12. o-\(Trialkylstannyl\)anilines and Their Utility in Stille Cross-Coupling: Direct Introduction of the 2-Aminophenyl Substituent - PMC \[pmc.ncbi.nlm.nih.gov\]](#)
- [13. studysmarter.co.uk \[studysmarter.co.uk\]](#)
- [14. How to Prevent Catalyst Poisoning at the Industrial Scale - Applied Catalysts \[catalysts.com\]](#)
- To cite this document: BenchChem. [Technical Support Center: Catalyst Poisoning in Cross-Coupling Reactions of Anilines]. BenchChem, [2026]. [Online PDF]. Available at:

[\[https://www.benchchem.com/product/b1444340/docs#technical-support-center-catalyst-poisoning-in-cross-coupling-reactions-of-anilines\]](https://www.benchchem.com/product/b1444340/docs#technical-support-center-catalyst-poisoning-in-cross-coupling-reactions-of-anilines)

### Disclaimer & Data Validity:

The information provided in this document is for Research Use Only (RUO) and is strictly not intended for diagnostic or therapeutic procedures. While BenchChem strives to provide accurate protocols, we make no warranties, express or implied, regarding the fitness of this product for every specific experimental setup.

**Technical Support:** The protocols provided are for reference purposes. Unsure if this reagent suits your experiment?

**Need Industrial/Bulk Grade?** [Request Custom Synthesis Quote](#)

## BenchChem

Our mission is to be the trusted global source of essential and advanced chemicals, empowering scientists and researchers to drive progress in science and industry.

### Contact

Address: 3281 E Guasti Rd  
Ontario, CA 91761, United States  
Phone: (601) 213-4426  
Email: [info@benchchem.com](mailto:info@benchchem.com)

[Contact our Ph.D. Support Team for a compatibility check](#)