

Application Notes and Protocols for the Functionalization of the Pyrazole Ring

Author: BenchChem Technical Support Team. **Date:** May 2026

Compound of Interest

Compound Name: *4-Bromo-1-(2-methylphenyl)pyrazole*

CAS No.: *1337607-03-0*

Cat. No.: *B1526731*

[Get Quote](#)

Introduction: The Pyrazole Scaffold in Modern Chemistry

The pyrazole nucleus is a privileged five-membered heterocyclic motif that forms the core of numerous compounds across pharmaceuticals, agrochemicals, and material science.[1] Its unique electronic properties, combined with the presence of two adjacent nitrogen atoms, offer multiple sites for modification, making it a versatile scaffold for tuning physicochemical and biological properties.[2] Molecules incorporating the pyrazole ring, such as the anti-inflammatory drug Celecoxib and the insecticide Fipronil, highlight the profound impact of this heterocycle.[3]

The ability to selectively introduce functional groups at specific positions on the pyrazole ring is paramount for modern drug discovery and development. Late-stage functionalization, in particular, allows for the rapid generation of analog libraries from a common intermediate, accelerating the structure-activity relationship (SAR) studies.[4] This guide provides a detailed overview of key methodologies for pyrazole functionalization, focusing on the underlying chemical principles and offering field-tested protocols for researchers and scientists. We will

explore strategies for substitution at both the nitrogen and carbon atoms of the ring, emphasizing regiochemical control, a critical challenge in pyrazole chemistry.

I. Understanding the Reactivity of the Pyrazole Ring

The pyrazole ring is an electron-rich aromatic system, yet its reactivity is nuanced due to the presence of two distinct nitrogen atoms and three carbon atoms.[5] Understanding the intrinsic electronic properties of each position is the cornerstone of designing selective functionalization strategies.

- **N1 (Pyrrole-like Nitrogen):** This nitrogen is sp^2 -hybridized, and its lone pair participates in the aromatic sextet. It is acidic and can be deprotonated with a base to form a nucleophilic pyrazolate anion.
- **N2 (Pyridine-like Nitrogen):** This nitrogen is also sp^2 -hybridized, but its lone pair lies in the plane of the ring and is not part of the aromatic system. It is basic and is the site of protonation in acidic media.[5]
- **C3 and C5 Positions:** These carbons are adjacent to the nitrogen atoms and are relatively electron-deficient, making them susceptible to attack by strong nucleophiles or organometallic reagents after deprotonation.[4] The C5 proton is generally the most acidic C-H bond on the ring.[2]
- **C4 Position:** This carbon is the most electron-rich and behaves like a position in an electron-rich aromatic system. It is the preferred site for electrophilic aromatic substitution.[5][6]

This differential reactivity allows for a position-selective approach to functionalization, as summarized in the diagram below.

Caption: Inherent reactivity map of the pyrazole scaffold.

II. N-Functionalization: Mastering Regioselectivity

Alkylation or arylation at the nitrogen atoms is one of the most common transformations for pyrazoles. However, for unsymmetrically substituted pyrazoles (e.g., 3-methylpyrazole), direct functionalization often yields a mixture of N1 and N2 regioisomers due to tautomerism, posing

significant purification challenges.[4][7] The choice of base, solvent, and counter-ion can profoundly influence the isomeric ratio.

Causality Behind Regioselective N-Alkylation

The regioselectivity of N-alkylation is a classic example of kinetic versus thermodynamic control, influenced by sterics and the nature of the pyrazolate anion in solution.

- Kinetic Control (N2-Alkylation): The N2 nitrogen is sterically more accessible and more basic, often leading to it being the initial site of attack, especially with reactive alkylating agents.
- Thermodynamic Control (N1-Alkylation): The N1-substituted product is often thermodynamically more stable, particularly when a bulky substituent is present at the C3 position. Using conditions that allow for equilibration, such as weaker bases or higher temperatures, can favor the N1 isomer. For instance, using K_2CO_3 in DMSO often favors N1 alkylation because the potassium cation coordinates with the N2 nitrogen, sterically hindering it and directing the alkylating agent to the N1 position.[8]

Protocol 1: Regioselective N1-Alkylation of 3-Methylpyrazole

This protocol is optimized for the preferential synthesis of the N1-alkylated product, leveraging the steric influence of the C3-methyl group and potassium carbonate as the base.[8]

Materials:

- 3-Methylpyrazole (1.0 equiv)
- Alkyl halide (e.g., Benzyl bromide, 1.1 equiv)
- Potassium carbonate (K_2CO_3), anhydrous (2.0 equiv)
- Dimethyl sulfoxide (DMSO), anhydrous
- Ethyl acetate
- Deionized water

- Brine (saturated NaCl solution)
- Anhydrous sodium sulfate (Na_2SO_4)

Procedure:

- To a clean, dry round-bottom flask equipped with a magnetic stir bar, add 3-methylpyrazole (1.0 equiv) and anhydrous DMSO.
- Add anhydrous potassium carbonate (2.0 equiv) to the solution.
- Stir the resulting suspension at room temperature for 20-30 minutes to ensure the formation of the potassium pyrazolate salt.
- Add the alkylating agent (1.1 equiv) dropwise to the suspension.
- Stir the reaction at room temperature. Monitor the reaction progress by Thin Layer Chromatography (TLC) or LC-MS until the starting material is consumed (typically 4-12 hours).
- Upon completion, carefully pour the reaction mixture into a separatory funnel containing deionized water.
- Extract the aqueous layer with ethyl acetate (3 x volume of DMSO).
- Combine the organic extracts and wash with brine to remove residual DMSO.
- Dry the organic layer over anhydrous Na_2SO_4 , filter, and concentrate the solvent under reduced pressure.
- Purify the crude product by flash column chromatography on silica gel to separate the regioisomers.

Self-Validation: The success of the regioselective alkylation is confirmed by ^1H NMR spectroscopy. The chemical shifts of the pyrazole ring protons are distinct for the N1 and N2 isomers, allowing for unambiguous structural assignment and calculation of the isomeric ratio.

Protocol 2: Copper-Catalyzed N-Arylation (Ullmann Condensation)

The Ullmann reaction is a cost-effective method for forming C-N bonds, particularly suitable for N-arylation of azoles. Modern protocols utilize catalytic amounts of copper with ligands to achieve high yields under milder conditions than traditional methods.^{[9][10]}

Materials:

- Pyrazole (1.0 equiv)
- Aryl iodide or bromide (1.2 equiv)
- Copper(I) iodide (CuI, 0.1 equiv)
- N,N'-Dimethylethylenediamine (DMEDA, 0.2 equiv)
- Potassium carbonate (K₂CO₃, 2.0 equiv)
- Toluene, anhydrous
- Celite

Procedure:

- To an oven-dried Schlenk tube, add CuI (0.1 equiv), K₂CO₃ (2.0 equiv), and the pyrazole (1.0 equiv).
- Seal the tube with a septum, and evacuate and backfill with argon (repeat this cycle 3 times).
- Add anhydrous toluene via syringe, followed by the aryl halide (1.2 equiv) and the DMEDA ligand (0.2 equiv).
- Place the sealed tube in a preheated oil bath at 110 °C.
- Stir the reaction for 12-24 hours, monitoring progress by TLC or LC-MS.^[9]

- After cooling to room temperature, dilute the mixture with ethyl acetate and filter through a pad of Celite to remove insoluble copper salts.
- Concentrate the filtrate under reduced pressure.
- Purify the crude product by flash column chromatography on silica gel.

III. C-Functionalization: Precision on the Carbon Backbone

Directly modifying the carbon atoms of the pyrazole ring opens up vast chemical space. Modern transition-metal-catalyzed C-H activation has become a powerful alternative to traditional methods that require pre-functionalization (e.g., via halogenation).[\[11\]](#)

C4-Functionalization via Electrophilic Substitution

The C4 position is the most nucleophilic carbon, making it the prime target for electrophilic substitution reactions like halogenation. A C4-halogenated pyrazole is a versatile intermediate for subsequent cross-coupling reactions.[\[6\]](#)

Protocol 3: Electrophilic Bromination at C4

This protocol describes the bromination of a pyrazole using N-Bromosuccinimide (NBS), a convenient and solid electrophilic bromine source.

Materials:

- 1-Phenyl-1H-pyrazole (1.0 equiv)
- N-Bromosuccinimide (NBS, 1.05 equiv)
- Acetonitrile (CH₃CN)
- Sodium thiosulfate solution
- Dichloromethane (DCM)

Procedure:

- Dissolve 1-phenyl-1H-pyrazole (1.0 equiv) in acetonitrile in a round-bottom flask.
- Cool the solution to 0 °C in an ice bath.
- Add NBS (1.05 equiv) portion-wise over 15 minutes, ensuring the temperature remains below 5 °C.
- Allow the reaction to warm to room temperature and stir for 2-4 hours, monitoring by TLC.
- Once the reaction is complete, quench by adding a saturated aqueous solution of sodium thiosulfate to consume any remaining bromine.
- Extract the mixture with dichloromethane (3x).
- Combine the organic layers, wash with brine, dry over anhydrous Na₂SO₄, and concentrate under reduced pressure.
- The crude 4-bromo-1-phenyl-1H-pyrazole is often pure enough for the next step, or it can be purified by recrystallization or column chromatography.

C5-Functionalization via C-H Activation

The C5-proton is the most acidic C-H bond, making this position susceptible to deprotonation followed by reaction with an electrophile, or direct, transition-metal-catalyzed C-H activation. Palladium-catalyzed direct arylation is a highly efficient method for this transformation.^{[3][12]}

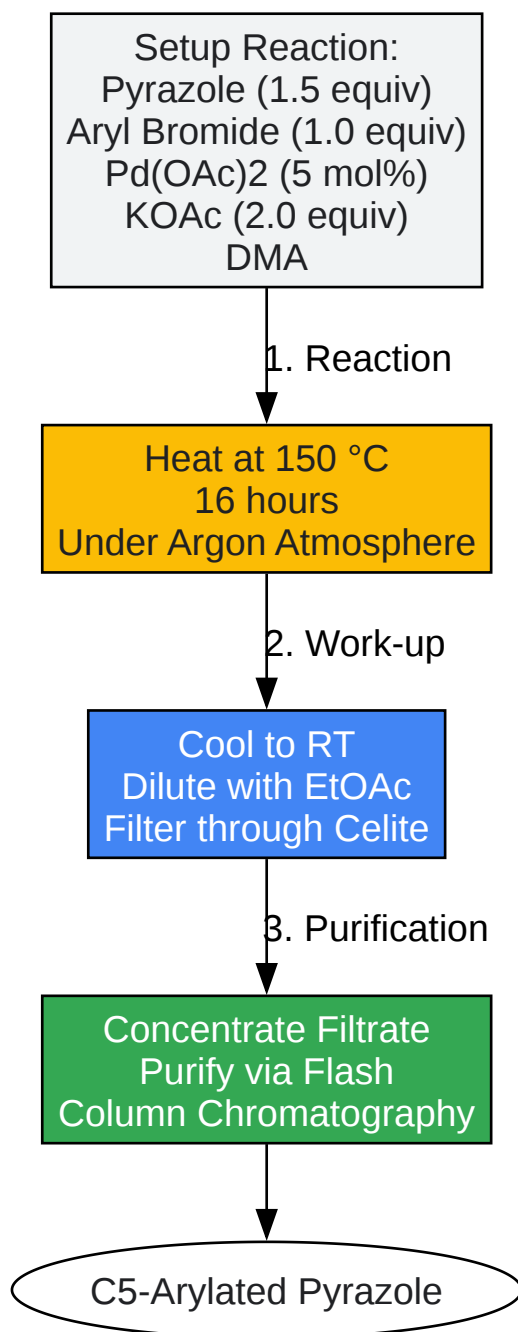

[Click to download full resolution via product page](#)

Need Custom Synthesis?

BenchChem offers custom synthesis for rare earth carbides and specific isotopic labeling.

Email: info@benchchem.com or [Request Quote Online](#).

Sources

- [1. lifechemicals.com](https://www.lifechemicals.com) [[lifechemicals.com](https://www.lifechemicals.com)]
- [2. researchgate.net](https://www.researchgate.net) [[researchgate.net](https://www.researchgate.net)]
- [3. Synthesis of C5-arylated pyrazoles from a pyrazole-4-carboxylate by a palladium-catalyzed C5–H bond activation/C4-decarboxylation sequence](https://www.comptes-rendus.academie-sciences.fr) [[comptes-rendus.academie-sciences.fr](https://www.comptes-rendus.academie-sciences.fr)]
- [4. Recent Synthetic Advances in C–H/N–H Functionalization of 1H-Pyrazoles: Diverse Strategies Across Various Substituted Scaffolds - PMC](https://pubmed.ncbi.nlm.nih.gov) [[pmc.ncbi.nlm.nih.gov](https://pubmed.ncbi.nlm.nih.gov)]
- [5. benchchem.com](https://www.benchchem.com) [[benchchem.com](https://www.benchchem.com)]
- [6. eguru.rrbdavc.org](https://www.eguru.rrbdavc.org) [[eguru.rrbdavc.org](https://www.eguru.rrbdavc.org)]
- [7. mdpi.com](https://www.mdpi.com) [[mdpi.com](https://www.mdpi.com)]
- [8. pdf.benchchem.com](https://pdf.benchchem.com) [pdf.benchchem.com]
- [9. pdf.benchchem.com](https://pdf.benchchem.com) [pdf.benchchem.com]
- [10. Copper-Diamine-Catalyzed N-Arylation of Pyrroles, Pyrazoles, Indazoles, Imidazoles, and Triazoles](https://www.organic-chemistry.org) [[organic-chemistry.org](https://www.organic-chemistry.org)]
- [11. Transition-metal-catalyzed C–H functionalization of pyrazoles - Organic & Biomolecular Chemistry \(RSC Publishing\)](https://pubs.rsc.org) [pubs.rsc.org]
- [12. researchgate.net](https://www.researchgate.net) [[researchgate.net](https://www.researchgate.net)]
- To cite this document: BenchChem. [Application Notes and Protocols for the Functionalization of the Pyrazole Ring]. BenchChem, [2026]. [Online PDF]. Available at: [<https://www.benchchem.com/product/b1526731/docs#application-notes-and-protocols-for-the-functionalization-of-the-pyrazole-ring>]

Disclaimer & Data Validity:

The information provided in this document is for Research Use Only (RUO) and is strictly not intended for diagnostic or therapeutic procedures. While BenchChem strives to provide accurate protocols, we make no warranties, express or implied, regarding the fitness of this product for every specific experimental setup.

Technical Support: The protocols provided are for reference purposes. Unsure if this reagent suits your experiment?

Need Industrial/Bulk Grade? [Request Custom Synthesis Quote](#)

BenchChem

Our mission is to be the trusted global source of essential and advanced chemicals, empowering scientists and researchers to drive progress in science and industry.

Contact

Address: 3281 E Guasti Rd
Ontario, CA 91761, United States
Phone: (601) 213-4426
Email: info@benchchem.com

[Contact our Ph.D. Support Team for a compatibility check](#)