

# analytical methods for n-(2-Bromophenyl)pyridine-3-carboxamide characterization

**Author:** BenchChem Technical Support Team. **Date:** April 2026

## Compound of Interest

Compound Name:	<i>n</i> -(2-Bromophenyl)pyridine-3-carboxamide
CAS No.:	75075-29-5
Cat. No.:	B14438903

[Get Quote](#)

## Analytical Method Development for N-(2-Bromophenyl)pyridine-3-carboxamide CAS No. 75075-29-5[1]

### Abstract

This application note details the analytical characterization and method development for **N-(2-Bromophenyl)pyridine-3-carboxamide**, a nicotinamide derivative often utilized as a scaffold in kinase inhibitor development and pharmaceutical synthesis. This guide provides a comprehensive protocol for structural confirmation (NMR, MS, IR), purity assessment (HPLC-UV), and solid-state characterization. It is designed for medicinal chemists and analytical scientists requiring rigorous validation standards.

### Molecule Profile & Synthetic Logic

Understanding the synthetic origin is critical for anticipating impurities. This molecule is typically synthesized via an amide coupling between Nicotinoyl chloride (or activated Nicotinic acid) and 2-Bromoaniline.

- IUPAC Name: **N-(2-Bromophenyl)pyridine-3-carboxamide**[1][2][3]
- Molecular Formula:  $C_{12}H_9BrN_2O$ [1]
- Molecular Weight: 277.12 g/mol
- Key Functional Groups: Pyridine (basic nitrogen), Amide (H-bond donor/acceptor), Aryl Bromide (halogen bonding/lipophilicity).

## Synthetic Pathway & Impurity Mapping

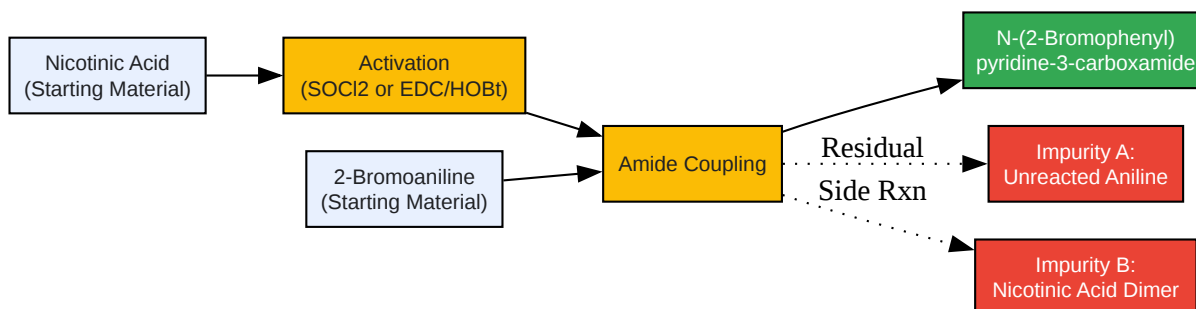

[Click to download full resolution via product page](#)

Figure 1: Synthetic pathway highlighting potential impurities that must be resolved by HPLC.

## Structural Identification Protocols

### A. Nuclear Magnetic Resonance (NMR) Spectroscopy

The presence of the electronegative bromine atom at the ortho position of the aniline ring and the electron-deficient pyridine ring creates a distinct chemical shift fingerprint.

Protocol:

- Solvent: DMSO- $d_6$  (Preferred for solubility and amide proton visibility).

- Concentration: 5–10 mg in 0.6 mL solvent.
- Reference: TMS (0.00 ppm) or DMSO residual peak (2.50 ppm).

Target Acceptance Criteria (<sup>1</sup>H NMR, 400 MHz, DMSO-d<sub>6</sub>):

Moiety	Proton	Multiplicity	Approx.[4][5] [6][7][8][9] Shift (δ ppm)	Mechanistic Explanation
Amide	NH	Broad Singlet	10.2 – 10.6	Deshielded by carbonyl anisotropy and H-bonding.
Pyridine	H-2	Singlet (d)	9.0 – 9.2	Most deshielded; adjacent to N and C=O.
Pyridine	H-6	Doublet	8.7 – 8.8	Adjacent to Nitrogen.
Pyridine	H-4	Doublet (dt)	8.2 – 8.3	Para to Nitrogen.
Aniline	H-6'	Doublet	7.9 – 8.1	Ortho to NH; deshielded by amide carbonyl effect.
Aniline	H-3'	Doublet	7.6 – 7.7	Ortho to Bromine; Br is electronegative.
Pyridine	H-5	Multiplet	7.5 – 7.6	Most shielded pyridine proton.
Aniline	H-4'/H-5'	Multiplet	7.1 – 7.4	Remaining aromatic protons.

“

*Note: The H-6' proton on the aniline ring is a critical diagnostic marker. In 2-bromoanilides, this proton often shifts downfield due to the proximity of the amide oxygen in the preferred conformer.*

## B. Mass Spectrometry (LC-MS)

The bromine atom provides a definitive isotopic signature essential for confirmation.

Protocol:

- Ionization: Electrospray Ionization (ESI), Positive Mode.
- Mobile Phase: 0.1% Formic Acid in Water/Acetonitrile.

Diagnostic Signals:

- Isotopic Pattern: A 1:1 ratio of peaks at  $m/z$  277 (Br) and  $m/z$  279 (Br).
- Fragmentation (MS/MS):
  - Loss of Br radical ( $M-79/81$ ).
  - Cleavage of the amide bond yielding the Nicotinoyl cation ( $m/z \sim 106$ ).

## C. Infrared Spectroscopy (FT-IR)

Method: ATR (Attenuated Total Reflectance) on solid powder.

- Amide I (C=O stretch):  $1650 - 1680 \text{ cm}^{-1}$  (Strong).

- Amide II (N-H bend): 1520 – 1550  $\text{cm}^{-1}$  (Medium).
- C-Br Stretch: 1000 – 1070  $\text{cm}^{-1}$  (Characteristic fingerprint).

## Purity Assessment (HPLC Method)

This method is designed to separate the product from the starting materials (Nicotinic acid: highly polar; 2-Bromoaniline: non-polar).

Method Parameters:

- Column: C18 Reverse Phase (e.g., Agilent Zorbax Eclipse Plus, 4.6 x 100 mm, 3.5  $\mu\text{m}$ ).
- Mobile Phase A: 0.1% Trifluoroacetic acid (TFA) in Water.
- Mobile Phase B: 0.1% TFA in Acetonitrile.
- Flow Rate: 1.0 mL/min.
- Detection: UV at 254 nm (Primary) and 280 nm.
- Temperature: 30°C.

Gradient Table:

Time (min)	% Mobile Phase B	Event
0.0	5	Equilibration
2.0	5	Hold (Elute polar salts)
12.0	95	Linear Gradient
15.0	95	Wash
15.1	5	Re-equilibration

Retention Logic:

- Nicotinic Acid (RT ~2-3 min): Elutes near void volume due to high polarity.

- Product (RT ~8-10 min): Intermediate polarity.
- 2-Bromoaniline (RT ~11-12 min): Elutes later due to lipophilic Br and phenyl ring.

## Solid State Characterization

For drug development applications, characterizing the physical form is mandatory.

- Melting Point:
  - Expected Range: 120°C – 160°C (Based on structural analogs).
  - Protocol: Capillary method, ramp rate 1°C/min near melt.
- Solubility Profile:
  - Soluble: DMSO, DMF, Methanol (warm), Dichloromethane.
  - Insoluble: Water, Hexane.

## Analytical Workflow Diagram

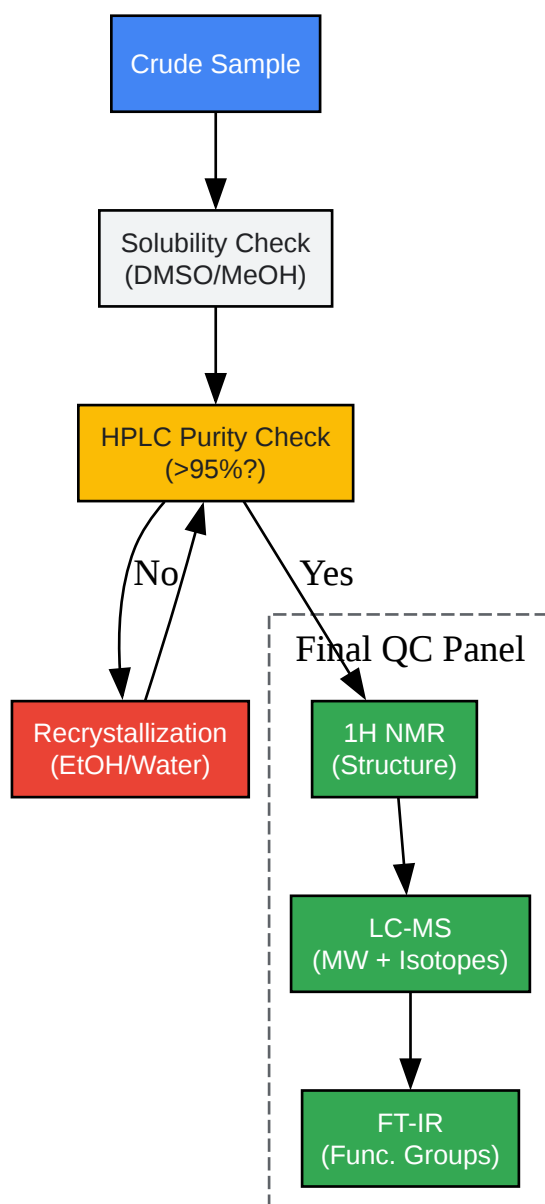

[Click to download full resolution via product page](#)

Figure 2: Step-by-step decision tree for the characterization of the synthesized compound.

## References

- ChemIndex Database. (2025). Entry for CAS 75075-29-5: **N-(2-bromophenyl)pyridine-3-carboxamide**.<sup>[1][2]</sup> Retrieved from
- Silverstein, R. M., Webster, F. X., & Kiemle, D. J. (2005). Spectrometric Identification of Organic Compounds (7th ed.). John Wiley & Sons.<sup>[10]</sup> (General reference for NMR shift

prediction of pyridine and aniline derivatives).

- Creative Proteomics. (2024). Nicotinamide Analysis Service: HPLC and LC-MS/MS Methodologies. Retrieved from
- Sarkis, N., & Sawan, A. (2022).[11] Development and validation of derivative UV spectroscopic method for simultaneous estimation of nicotinamide and tretinoin. BMC Chemistry, 16(1).[11] [Link](#)

### Need Custom Synthesis?

BenchChem offers custom synthesis for rare earth carbides and specific isotopic labeling.

Email: [info@benchchem.com](mailto:info@benchchem.com) or [Request Quote Online](#).

## Sources

- [1. 75075-29-5 | N-\(2-bromophenyl\)pyridine-3-carboxamide \[chemindex.com\]](#)
- [2. 75075-29-5 | N-\(2-bromophenyl\)pyridine-3-carboxamide \[chemindex.com\]](#)
- [3. 75075-29-5 | N-\(2-bromophenyl\)pyridine-3-carboxamide \[chemindex.com\]](#)
- [4. bmse000281 Nicotinamide at BMRB \[bmr.io\]](#)
- [5. chemscene.com \[chemscene.com\]](#)
- [6. PubChemLite - 2-pyridinecarboxamide, n-\(4-bromophenyl\)-3-mercapto- \(C12H9BrN2OS\) \[pubchemlite.lcsb.uni.lu\]](#)
- [7. savemyexams.com \[savemyexams.com\]](#)
- [8. N-\(2-bromophenyl\)-6-\(trifluoromethyl\)pyridine-3-carboxamide | Molport-011-265-693 | Novel \[molport.com\]](#)
- [9. mdpi.com \[mdpi.com\]](#)
- [10. spectrabase.com \[spectrabase.com\]](#)
- [11. ijnrd.org \[ijnrd.org\]](#)
- To cite this document: BenchChem. [analytical methods for n-(2-Bromophenyl)pyridine-3-carboxamide characterization]. BenchChem, [2026]. [Online PDF]. Available at: [\[https://www.benchchem.com/product/b14438903/docs#analytical-methods-for-n-2-bromophenyl-pyridine-3-carboxamide-characterization\]](https://www.benchchem.com/product/b14438903/docs#analytical-methods-for-n-2-bromophenyl-pyridine-3-carboxamide-characterization)

**Disclaimer & Data Validity:**

The information provided in this document is for Research Use Only (RUO) and is strictly not intended for diagnostic or therapeutic procedures. While BenchChem strives to provide accurate protocols, we make no warranties, express or implied, regarding the fitness of this product for every specific experimental setup.

**Technical Support:** The protocols provided are for reference purposes. Unsure if this reagent suits your experiment?

**Need Industrial/Bulk Grade?** [Request Custom Synthesis Quote](#)

## BenchChem

Our mission is to be the trusted global source of essential and advanced chemicals, empowering scientists and researchers to drive progress in science and industry.

### Contact

Address: 3281 E Guasti Rd  
Ontario, CA 91761, United States  
Phone: (601) 213-4426  
Email: [info@benchchem.com](mailto:info@benchchem.com)

[Contact our Ph.D. Support Team for a compatibility check](#)