

Application Notes and Protocols: Fluoroform as a Versatile Difluoromethylating Agent

Author: BenchChem Technical Support Team. **Date:** May 2026

Compound of Interest

Compound Name: *[Bromo(difluoro)methoxy]benzene*

CAS No.: 78031-09-1

Cat. No.: B14435573

[Get Quote](#)

Introduction: The Rising Prominence of the Difluoromethyl Group in Drug Discovery

The difluoromethyl (CF₂H) group has emerged as a critical structural motif in modern medicinal chemistry. Its unique stereoelectronic properties, acting as a lipophilic hydrogen bond donor and a bioisostere for hydroxyl or thiol groups, can significantly enhance the metabolic stability, membrane permeability, and binding affinity of drug candidates. However, the efficient and selective installation of this moiety remains a significant synthetic challenge. Fluoroform (HCF₃), an abundant and non-ozone-depleting industrial byproduct, presents an atom-economical and cost-effective solution. This guide provides an in-depth exploration of the methodologies for harnessing fluoroform as a difluoromethylating agent, complete with detailed protocols and mechanistic insights for researchers in drug development and organic synthesis.

Core Concepts: Activating the Inert Fluoroform

The primary hurdle in utilizing fluoroform lies in the low acidity of its C-H bond (pK_a ≈ 25–28), making deprotonation challenging.^[1] Successful difluoromethylation strategies hinge on two

distinct activation pathways: the generation of difluorocarbene and the umpolung approach involving C-F bond activation.

Mechanism 1: The Difluorocarbene Pathway

The most common approach involves the deprotonation of fluoroform with a strong base to form the transient trifluoromethyl anion (CF_3^-). This anion is highly unstable and rapidly undergoes α -elimination of a fluoride ion to generate the electrophilic singlet difluorocarbene ($:\text{CF}_2$).^{[1][2]} This highly reactive intermediate is then trapped by a suitable nucleophile to yield the difluoromethylated product. This pathway is particularly effective for the difluoromethylation of heteroatom nucleophiles such as phenols and thiophenols.^[3]

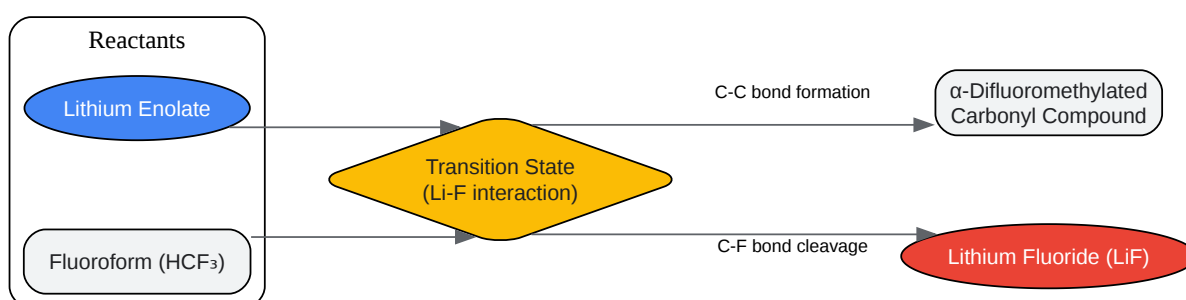
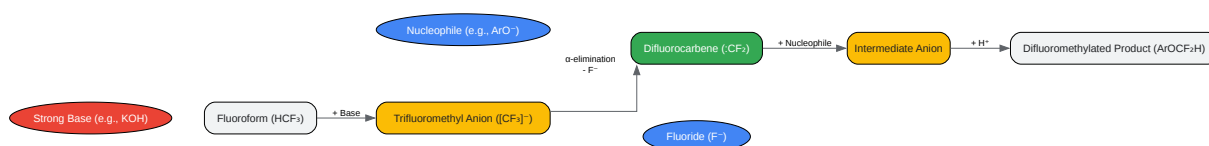

[Click to download full resolution via product page](#)

Caption: Umpolung difluoromethylation of a lithium enolate.

Experimental Protocols

Protocol 1: O-Difluoromethylation of Phenols via Difluorocarbene Generation

This protocol details the difluoromethylation of 4-bromophenol using a two-phase system, adapted from the procedure described by Dolbier and co-workers. [\[3\]](#) Workflow Diagram:

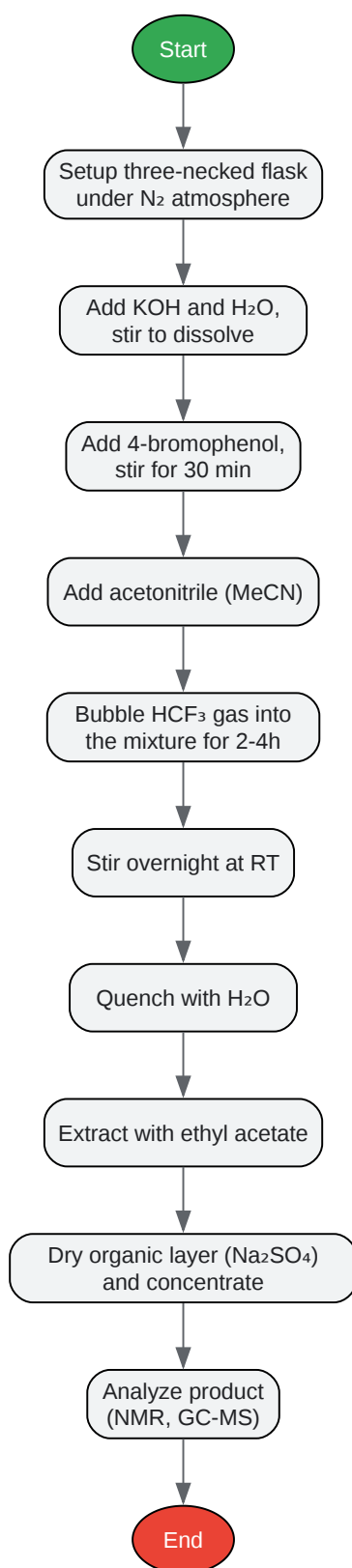

[Click to download full resolution via product page](#)

Caption: Workflow for the difluoromethylation of phenols.

Materials and Reagents:

Reagent/Material	Quantity	Moles (mmol)	Equivalents
4-Bromophenol	0.52 g	3	1
Potassium Hydroxide (KOH)	2.52 g	45	15
Deionized Water	2.5 g	-	-
Acetonitrile (MeCN)	10 mL	-	-
Fluoroform (HCF ₃)	Gas cylinder	-	Excess
Ethyl Acetate	As needed	-	-
Anhydrous Sodium Sulfate	As needed	-	-

Step-by-Step Procedure:

- **Reaction Setup:** Equip a 100 mL three-necked round-bottom flask with a magnetic stir bar, a gas inlet tube, a condenser, and a gas outlet connected to an oil bubbler. Purge the system with nitrogen gas.
- **Base and Substrate Addition:** Under a nitrogen atmosphere, add potassium hydroxide (2.52 g) and deionized water (2.5 g) to the flask. Stir until the KOH is nearly dissolved. Add 4-bromophenol (0.52 g) and continue stirring for 30 minutes at room temperature. [3]3. **Solvent Addition:** Add acetonitrile (10 mL) via syringe.
- **Introduction of Fluoroform:** Slowly bubble fluoroform gas from a cylinder through the stirred mixture via the gas inlet tube. A slow, steady stream of bubbles should be maintained. Continue bubbling for 2-4 hours. Caution: This step must be performed in a well-ventilated fume hood.
- **Reaction:** After the addition of fluoroform is complete, allow the mixture to stir overnight at room temperature.

- Work-up: Quench the reaction by carefully adding 20 mL of deionized water. Transfer the mixture to a separatory funnel and extract with ethyl acetate (3 x 20 mL).
- Isolation: Combine the organic layers, dry over anhydrous sodium sulfate, filter, and concentrate under reduced pressure to yield the crude product, 1-bromo-4-(difluoromethoxy)benzene.
- Purification and Analysis: Purify the product by column chromatography on silica gel if necessary. Characterize the product by ^1H NMR, ^{19}F NMR, and GC-MS. The yield should be in the range of 70-85%. [3]

Protocol 2: Continuous Flow α -Difluoromethylation of a Protected Amino Acid

This protocol is based on the work of Kappe and co-workers and demonstrates the advantages of continuous flow for gas-liquid reactions. [2][4] This method allows for safe and efficient handling of fluoroform with precise control over reaction parameters.

Materials and Reagents:

Reagent/Material	Concentration/Amount
N-(Diphenylmethylene)glycine methyl ester	0.1 M in THF
Lithium bis(trimethylsilyl)amide (LiHMDS)	1.0 M in THF
Fluoroform (HCF_3)	Gas cylinder
Tetrahydrofuran (THF)	Anhydrous

Experimental Setup:

A continuous flow system consisting of two syringe pumps for the liquid feeds, a mass flow controller for the fluoroform gas, a T-mixer, a heated coil reactor, and a back-pressure regulator.

Step-by-Step Procedure:

- **System Preparation:** Set up the continuous flow reactor system in a fume hood. Ensure all connections are secure. Purge the system with an inert gas (e.g., nitrogen).
- **Reagent Preparation:** Prepare a 0.1 M solution of N-(diphenylmethylene)glycine methyl ester in anhydrous THF.
- **Reaction Initiation:** Pump the substrate solution and the LiHMDS solution into the T-mixer at controlled flow rates. Simultaneously, introduce a stream of fluoroform gas into the T-mixer. The stoichiometry is typically adjusted to use 2 equivalents of base and 3 equivalents of fluoroform relative to the substrate. [2]4. **Reaction in Flow:** The resulting gas-liquid mixture flows through the heated coil reactor. A typical residence time is 20 minutes at a controlled temperature.
- **Collection and Quenching:** The product stream exits the reactor through a back-pressure regulator and is collected in a flask containing a quenching solution (e.g., saturated aqueous ammonium chloride).
- **Work-up and Analysis:** The collected mixture is worked up using standard extraction procedures. The product, the C α -difluoromethylated amino acid derivative, is then purified and analyzed. This continuous process allows for high atom economy and scalability.

Safety and Handling of Fluoroform

Fluoroform is a non-flammable, colorless gas. While it has low toxicity, it is an asphyxiant in high concentrations and a potent greenhouse gas. [5]

- **Handling:** Always handle fluoroform in a well-ventilated fume hood. [6] Use equipment rated for cylinder pressure and check for leaks before use. [5]* **Personal Protective Equipment (PPE):** Standard PPE, including safety glasses, a lab coat, and gloves, should be worn. [6] When dealing with potential liquid splashes, thermal insulating gloves and a face shield are recommended. [5]* **Storage:** Store fluoroform cylinders upright in a cool, dry, well-ventilated area away from incompatible materials. [5]* **Disposal:** Unused fluoroform should be returned to the supplier. Do not attempt to vent large quantities to the atmosphere.

Comparative Analysis and Outlook

Feature	Difluorocarbene Pathway	Umpolung (C-F Activation) Pathway
Typical Substrates	Phenols, thiophenols, amines (heteroatom nucleophiles)	Ketones, esters, amides (carbon nucleophiles via enolates)
Base	Strong, inexpensive bases (e.g., KOH)	Strong, non-nucleophilic bases (e.g., LiHMDS, LDA)
Key Intermediate	:CF ₂ (Difluorocarbene)	Metal-coordinated fluoroform
Bond Formed	C(sp ²)-O/S/N-CF ₂ H	C(sp ³)-CF ₂ H
Advantages	Milder conditions, broader functional group tolerance for heteroatoms	Access to challenging C-C bonds, formation of all-carbon quaternary centers
Limitations	Limited to heteroatom nucleophiles	Requires strong, expensive bases and anhydrous conditions

The use of fluoroform as a difluoromethylating agent is a rapidly evolving field. The development of continuous flow technologies has significantly improved the safety and efficiency of these reactions, making them more amenable to industrial applications. [1] [4] Future research will likely focus on expanding the substrate scope of the umpolung strategy and developing catalytic methods to activate fluoroform under even milder conditions, further solidifying its role as a sustainable and powerful tool in synthetic chemistry.

References

- G. K. S. Prakash, P. V. Ramachandran, R. V. P. Vadde, G. A. Olah. Difluoromethylation and Trifluoromethylation Reagents Derived from Tetrafluoroethane β -Sultone. *Beilstein Journal of Organic Chemistry*, 2013, 9, 2726-2733. Available from: [\[Link\]](#)
- M. Köckinger, T. Ciaglia, M. Bersier, P. Hanselmann, B. Gutmann, C. O. Kappe. Utilization of fluoroform for difluoromethylation in continuous flow: a concise synthesis of α -difluoromethyl-amino acids. *Green Chemistry*, 2018, 20, 108-112. Available from: [\[Link\]](#)

- T. Iida, R. Hashimoto, K. Aikawa, S. Ito, K. Mikami. Umpolung of Fluoroform by C-F Bond Activation: Direct Difluoromethylation of Lithium Enolates. *Angewandte Chemie International Edition*, 2012, 51(38), 9535-9538. Available from: [\[Link\]](#)
- W. R. Dolbier Jr., C. S. Thomason, L. Wang. Use of Fluoroform as a Source of Difluorocarbene in the Synthesis of Difluoromethoxy- and Difluorothiomethoxyarenes. *The Journal of Organic Chemistry*, 2013, 78(17), 8930-8935. Available from: [\[Link\]](#)
- A. M. Szpilman, S. Maity. 2-Fluoroenones via an Umpolung Morita-Baylis-Hillman Reaction of Enones. *Organic Letters*, 2023, 25(8), 1218-1222. Available from: [\[Link\]](#)
- X. Y. Liu, C. O. Kappe. Continuous flow strategies for using fluorinated greenhouse gases in fluoroalkylations. *Chemical Society Reviews*, 2021, 50(12), 7378-7395. Available from: [\[Link\]](#)
- M. Köckinger, T. Ciaglia, M. Bersier, P. Hanselmann, B. Gutmann, C. O. Kappe. Utilization of fluoroform for difluoromethylation in continuous flow: a concise synthesis of α -difluoromethyl-amino acids. *Green Chemistry*, 2018, 20, 108-112. Available from: [\[Link\]](#)
- S. Barata-Vallejo, M. V. Cooke, A. Postigo. Radical Fluoroalkylation Reactions. *ACS Catalysis*, 2018, 8(8), 7287-7307. Available from: [\[Link\]](#)
- J. Hu, L. Zhang, J. Zheng. 2-Chloro-2,2-difluoroacetophenone: A Non-ODS-based difluorocarbene precursor and its use in the difluoromethylation of phenol derivatives. *The Journal of Organic Chemistry*, 2006, 71(26), 9845-9848. Available from: [\[Link\]](#)
- T. Furuya, A. S. Kamlet, T. Ritter. Catalysis for Fluorination and Trifluoromethylation. *Nature*, 2011, 473, 470-477. Available from: [\[Link\]](#)
- Matheson Tri-Gas. Material Safety Data Sheet: Fluoroform. Available from: [\[Link\]](#)
- C. O. Kappe, B. Gutmann. Utilization of fluoroform for difluoromethylation in continuous flow: a concise synthesis of α -difluoromethyl-amino acids. *Scientific Update*, 2018. Available from: [\[Link\]](#)
- Halocarbon Products Corporation. Halocarbon R-23 (Trifluoromethane) - SAFETY DATA SHEET. 2025. Available from: [\[Link\]](#)

Need Custom Synthesis?

BenchChem offers custom synthesis for rare earth carbides and specific isotopic labeling.

Email: info@benchchem.com or [Request Quote Online](#).

Sources

- [1. ira.lib.polyu.edu.hk](http://ira.lib.polyu.edu.hk) [ira.lib.polyu.edu.hk]
- [2. Utilization of fluoroform for difluoromethylation in continuous flow: a concise synthesis of \$\alpha\$ -difluoromethyl-amino acids - Green Chemistry \(RSC Publishing\)](#)
DOI:10.1039/C7GC02913F [pubs.rsc.org]
- [3. pubs.acs.org](http://pubs.acs.org) [pubs.acs.org]
- [4. scientificupdate.com](http://scientificupdate.com) [scientificupdate.com]
- [5. airgas.com](http://airgas.com) [airgas.com]
- [6. apps.mnc.umn.edu](http://apps.mnc.umn.edu) [apps.mnc.umn.edu]
- To cite this document: BenchChem. [Application Notes and Protocols: Fluoroform as a Versatile Difluoromethylating Agent]. BenchChem, [2026]. [Online PDF]. Available at: [<https://www.benchchem.com/product/b14435573/docs#application-notes-and-protocols-fluoroform-as-a-versatile-difluoromethylating-agent>]

Disclaimer & Data Validity:

The information provided in this document is for Research Use Only (RUO) and is strictly not intended for diagnostic or therapeutic procedures. While BenchChem strives to provide accurate protocols, we make no warranties, express or implied, regarding the fitness of this product for every specific experimental setup.

Technical Support: The protocols provided are for reference purposes. Unsure if this reagent suits your experiment?

Need Industrial/Bulk Grade? [Request Custom Synthesis Quote](#)

BenchChem

Our mission is to be the trusted global source of essential and advanced chemicals, empowering scientists and researchers to drive progress in science and industry.

Contact

Address: 3281 E Guasti Rd
Ontario, CA 91761, United States
Phone: (601) 213-4426
Email: info@benchchem.com

[Contact our Ph.D. Support Team for a compatibility check](#)