

Technical Support Center: Resolution of Trifluorophenylmethanamine Isomers

Author: BenchChem Technical Support Team. **Date:** May 2026

Compound of Interest

Compound Name:	(2,3,5-Trifluorophenyl)methanamine hydrochloride
CAS No.:	643088-06-6
Cat. No.:	B1443849

[Get Quote](#)

Welcome to the technical support center for the chiral resolution of trifluorophenylmethanamine. This guide is designed for researchers, scientists, and drug development professionals, offering in-depth, field-proven insights into the separation of these critical enantiomers. The presence of the trifluoromethyl group can significantly influence a molecule's biological activity, making the isolation of single enantiomers a crucial step in pharmaceutical development.[1][2] This document provides a structured approach to troubleshooting common experimental hurdles and answers frequently asked questions to streamline your method development process.

Frequently Asked Questions (FAQs)

This section addresses common questions regarding the strategy and theory behind resolving trifluorophenylmethanamine enantiomers.

Q1: What are the primary methods for resolving racemic trifluorophenylmethanamine?

There are three main strategies for resolving racemic trifluorophenylmethanamine, each with distinct advantages and applications:

- **Diastereomeric Salt Crystallization:** This is a classical and highly scalable method.^[3] It involves reacting the racemic amine with a single enantiomer of a chiral acid (a resolving agent). This reaction creates a pair of diastereomeric salts which, unlike enantiomers, have different physical properties like solubility, allowing them to be separated by fractional crystallization.^{[4][5]}
- **Chiral Chromatography (HPLC/SFC):** This is the most common analytical technique for determining enantiomeric purity (e.e., enantiomeric excess) and is also widely used for preparative-scale separations.^{[6][7]} The separation occurs on a chiral stationary phase (CSP) that interacts differently with each enantiomer, leading to different retention times.^{[8][9]}
- **Enzymatic Resolution:** This highly selective method uses an enzyme (e.g., a lipase) as a biocatalyst to selectively react with one enantiomer of the racemic mixture.^{[10][11]} For example, an enzyme could acylate the (R)-enantiomer, leaving the (S)-enantiomer unreacted, allowing for their separation. This is a type of kinetic resolution.^{[12][13]}

Q2: How do I choose the best resolution method for my needs?

The choice depends on your scale, purity requirements, and available resources.

- For large-scale production (multi-gram to kg): Diastereomeric salt crystallization is often the most cost-effective and practical approach.^[4]
- For high-purity analytical assessment: Chiral High-Performance Liquid Chromatography (HPLC) or Supercritical Fluid Chromatography (SFC) is the gold standard for accurately determining enantiomeric excess.^[7]
- For small-scale preparative work or when other methods fail: Preparative chiral chromatography can provide high-purity enantiomers directly, albeit at a higher cost per gram than crystallization.^[14]
- For "green" chemistry approaches or highly specific transformations: Enzymatic resolution offers mild reaction conditions and exceptional selectivity, though it may require significant

screening to find a suitable enzyme.[15]

Q3: What are common chiral resolving agents for amines like trifluorophenylmethanamine?

The selection of a resolving agent is often empirical. For amines, chiral acids are used as resolving agents. Commonly successful candidates include:

- Tartaric acid derivatives (e.g., L- or D-tartaric acid)[3]
- Mandelic acid derivatives (e.g., (R)- or (S)-mandelic acid)[3]
- (R)- or (S)-Camphorsulfonic acid[3]

A screening process with several agents and solvents is the most reliable way to identify optimal conditions.[4]

Q4: Why is derivatization sometimes needed for chiral HPLC analysis?

While direct separation is often possible, primary amines can sometimes exhibit poor peak shape or interact strongly with the silica surface of the column, a phenomenon known as silanol interaction.[16] Derivatizing the amine with a suitable agent, such as (+)-1-(9-fluorenyl)ethyl chloroformate (FLEC), can improve chromatographic behavior and enhance detection.[17]

Troubleshooting Guide: Diastereomeric Salt Crystallization

This guide addresses specific issues that may arise during the resolution of trifluorophenylmethanamine via diastereomeric salt formation.

Problem	Probable Cause(s)	Step-by-Step Solution
No salt formation or precipitation occurs after adding the resolving agent.	<p>1. Inappropriate Solvent: The diastereomeric salt may be too soluble in the chosen solvent.</p> <p>2. Low Concentration: Reactant concentrations may be below the threshold for precipitation.</p> <p>3. Unsuitable Resolving Agent: The chosen chiral acid may not form a stable, crystalline salt with the amine.[7]</p>	<p>1. Solvent Screening: Screen a variety of solvents with different polarities (e.g., ethanol, isopropanol, acetonitrile, ethyl acetate).[7]</p> <p>2. Increase Concentration: Carefully increase the concentration of the amine and resolving agent.</p> <p>3. Change Resolving Agent: Select an alternative chiral resolving agent from the recommended list (e.g., switch from tartaric acid to mandelic acid).[7]</p>
The precipitate is an oil or fails to crystallize ("oiling out").	<p>1. Suboptimal Solvent System: The solvent may be too good at solvating the salt, preventing lattice formation.</p> <p>2. Presence of Impurities: Impurities in the racemic amine can inhibit crystallization.</p> <p>3. Cooling Rate: Cooling the solution too quickly can favor oiling over crystallization.</p>	<p>1. Use an Anti-Solvent: Introduce a solvent in which the salt is less soluble (an anti-solvent) to induce crystallization.[7]</p> <p>2. Slow Cooling: Allow the solution to cool slowly to room temperature, followed by further cooling in an ice bath or refrigerator.</p> <p>3. Purify Starting Material: Ensure the starting racemic trifluorophenylmethanamine is of high purity.</p>
Low enantiomeric excess (e.e.) of the desired enantiomer after crystallization.	<p>1. Co-precipitation: Both diastereomeric salts may have similar solubilities, leading to their precipitating together.</p> <p>2. Incomplete Reaction: The reaction between the amine and resolving agent may not</p>	<p>1. Recrystallization: Perform one or more recrystallizations of the diastereomeric salt to improve its purity.</p> <p>2. Solvent/Temperature Optimization: Experiment with different solvents and</p>

have gone to completion. 3.

Suboptimal Stoichiometry: The molar ratio of the amine to the resolving agent may not be optimal.

crystallization temperatures to maximize the solubility difference between the diastereomers. 3. Adjust Stoichiometry: Vary the molar equivalents of the resolving agent (e.g., try 0.5 or 1.0 equivalents).

Troubleshooting Guide: Chiral HPLC/SFC Analysis

This guide focuses on resolving common issues encountered during the analytical separation of trifluorophenylmethanamine enantiomers.

Problem	Probable Cause(s)	Step-by-Step Solution
Poor or no separation of enantiomers.	<p>1. Incorrect Chiral Stationary Phase (CSP): The selected CSP does not have the right chiral recognition mechanism for the analyte. 2. Inappropriate Mobile Phase: The mobile phase composition (solvents and additives) is not optimal for the separation.[18]</p>	<p>1. Screen Columns: Test a range of CSPs with different selectivities (e.g., polysaccharide-based like ChiralPak® IA/IB/IC, or cyclofructan-based).[14][16] 2. Mobile Phase Optimization: Systematically vary the mobile phase composition. For normal phase, adjust the alcohol modifier (e.g., isopropanol, ethanol) percentage. For SFC, adjust the co-solvent percentage. 3. Use Additives: For basic amines, adding a small amount of a basic additive (e.g., diethylamine, butylamine) to the mobile phase can improve peak shape and resolution.[16]</p>
Poor peak shape (tailing or fronting).	<p>1. Silanol Interactions: The basic amine is interacting with acidic silanol groups on the silica support.[16] 2. Column Overload: Too much sample has been injected. 3. Column Contamination/Damage: The column performance has degraded over time.[19]</p>	<p>1. Add Mobile Phase Modifier: Introduce a basic additive like diethylamine (typically 0.1%) to the mobile phase to block active silanol sites. 2. Reduce Injection Volume/Concentration: Decrease the amount of sample injected onto the column. 3. Flush the Column: Flush the column with a strong solvent (as recommended by the manufacturer). If performance does not improve,</p>

the column may need replacement.

Drifting retention times.	1. Insufficient Column Equilibration: The column has not been properly equilibrated with the mobile phase. 2. Mobile Phase Composition Change: Selective evaporation of a volatile solvent component from the mobile phase reservoir. 3. Temperature Fluctuations: The column temperature is not stable.	1. Equilibrate Longer: Allow the mobile phase to run through the column for at least 10-20 column volumes before injecting. 2. Cover Reservoirs: Keep mobile phase bottles covered to minimize evaporation. 3. Use a Column Oven: Employ a column thermostat to maintain a constant temperature.

Experimental Protocols

Protocol 1: Diastereomeric Salt Resolution (General Procedure)

This protocol provides a foundational methodology for resolving racemic trifluorophenylmethanamine. It should be optimized by screening different resolving agents and solvents.

1. Salt Formation: a. Dissolve 1.0 equivalent of racemic trifluorophenylmethanamine in a suitable solvent (e.g., methanol, ethanol, or isopropanol) with gentle heating. b. In a separate flask, dissolve 0.5-1.0 equivalents of the chiral resolving agent (e.g., L-(+)-tartaric acid) in the minimum amount of the same solvent. c. Slowly add the resolving agent solution to the amine solution with stirring. d. Allow the mixture to cool slowly to room temperature. If crystallization does not occur, try scratching the inside of the flask or adding a seed crystal. e. Cool the mixture further in an ice bath for 1-2 hours to maximize precipitation.

2. Isolation and Purification: a. Filter the crystalline salt using a Buchner funnel and wash it with a small amount of cold solvent.^[3] b. Dry the salt under vacuum. c. To improve diastereomeric purity, recrystallize the salt from a suitable solvent.

3. Liberation of the Free Amine: a. Dissolve the purified diastereomeric salt in water. b. Add a base (e.g., 2M NaOH solution) until the solution is alkaline (pH > 10) to deprotonate the amine. c. Extract the liberated enantiomerically enriched amine with an organic solvent (e.g., dichloromethane or ethyl acetate) multiple times. d. Combine the organic layers, dry over an anhydrous salt (e.g., Na₂SO₄), filter, and concentrate under reduced pressure to yield the free amine.
4. Analysis: a. Determine the enantiomeric excess (e.e.) of the recovered amine using chiral HPLC (see Protocol 2).

Protocol 2: Chiral HPLC Method for Enantiomeric Excess (e.e.) Determination

This protocol outlines a starting point for developing an analytical method to determine the purity of trifluorophenylmethanamine enantiomers.

1. Column and Mobile Phase Selection: a. Column: A polysaccharide-based CSP such as a ChiralPak® column is a good starting point.^[16] b. Mobile Phase (Normal Phase): A mixture of a hydrocarbon (e.g., hexane or heptane) and an alcohol modifier (e.g., isopropanol or ethanol). A typical starting condition is 90:10 (v/v) Hexane:Isopropanol. c. Additive: Add 0.1% diethylamine (DEA) or butylamine to the mobile phase to improve peak symmetry.^[16]
2. HPLC System Setup: a. Flow Rate: 1.0 mL/min. b. Detection: UV detection at a wavelength where the compound absorbs (e.g., 254 nm). c. Column Temperature: 25 °C (use a column oven for stability).
3. Analysis Procedure: a. Equilibrate the column with the mobile phase until a stable baseline is achieved. b. Prepare a dilute solution of the racemic trifluorophenylmethanamine (~1 mg/mL) in the mobile phase. c. Inject a small volume (e.g., 5-10 µL) of the racemic standard to confirm the separation of the two enantiomer peaks. d. Prepare a solution of your resolved amine sample at a similar concentration. e. Inject the resolved sample and integrate the peak areas of both enantiomers. f. Calculate e.e.:
$$\text{e.e. (\%)} = [(\text{Area}_1 - \text{Area}_2) / (\text{Area}_1 + \text{Area}_2)] * 100$$
 where Area₁ is the area of the major enantiomer peak and Area₂ is the area of the minor enantiomer peak.

Visualizations

Workflow for Diastereomeric Salt Resolution

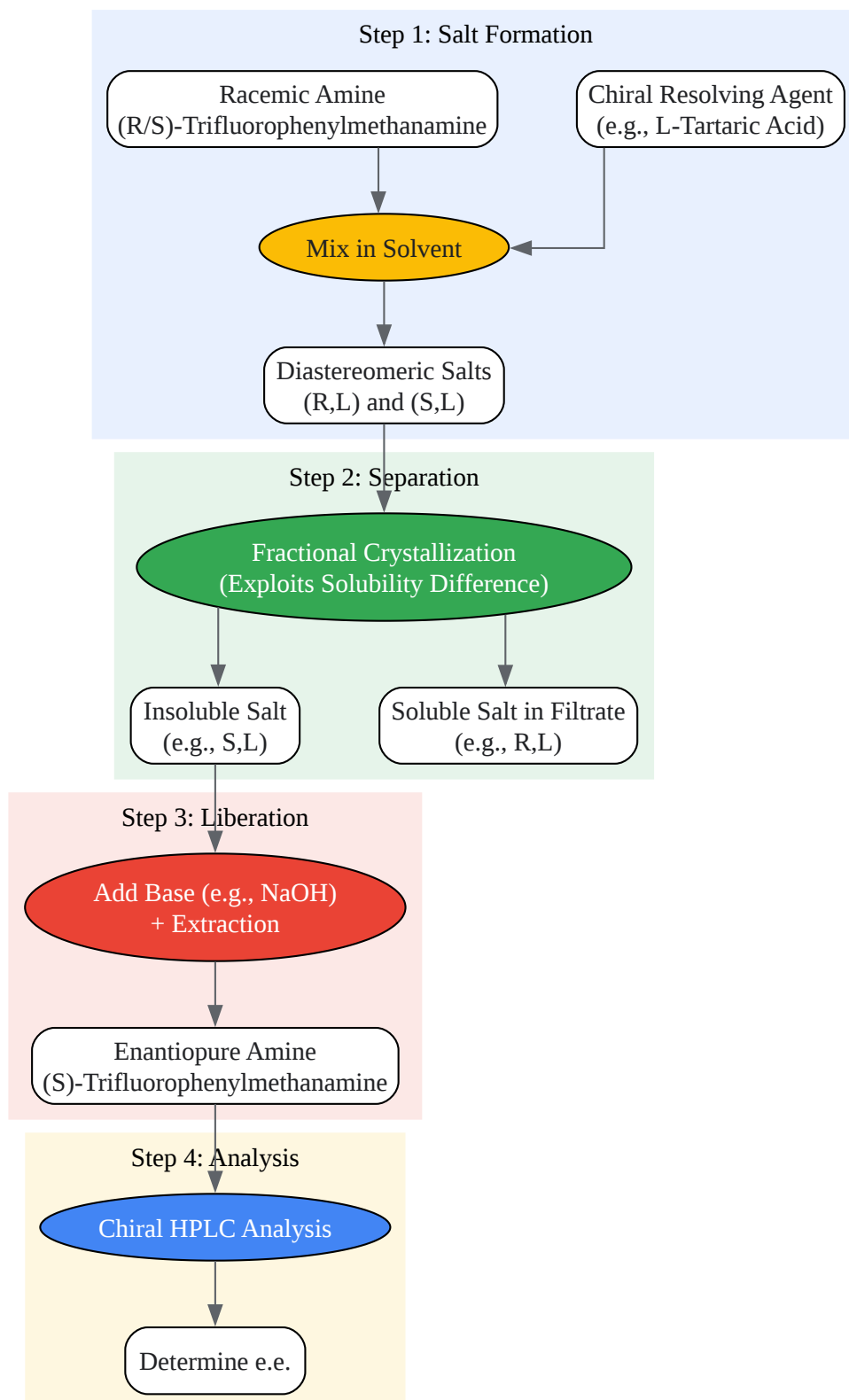

[Click to download full resolution via product page](#)

Caption: Workflow of chiral resolution by diastereomeric salt formation.

Principle of Chiral Chromatography

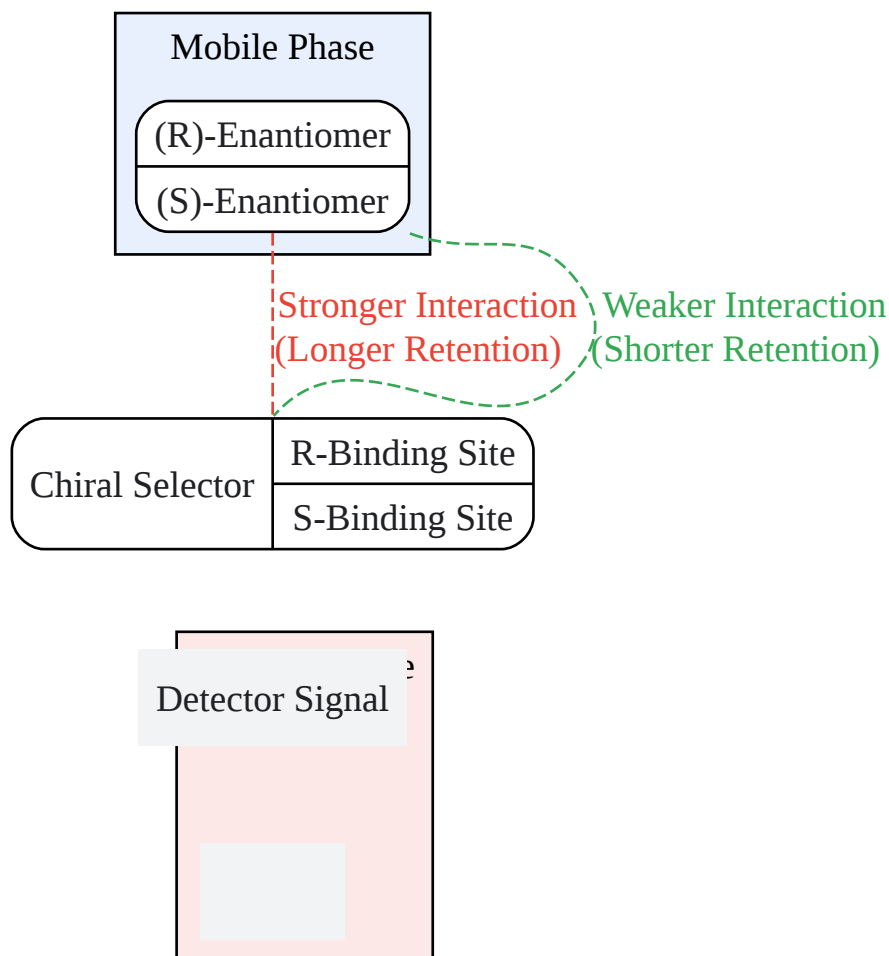

[Click to download full resolution via product page](#)

Caption: Principle of enantiomer separation on a chiral stationary phase.

References

- BenchChem. (n.d.). Navigating the Separation of Enantiomers: A Comparative Guide to Chiral Resolving Agents for Fluoro-methoxyphenyl-ethanamine.
- Einarsson, S., Josefsson, B., Möller, P., & Sanchez, D. (1987). Separation of amino acid enantiomers and chiral amines using precolumn derivatization with (+)-1-(9-fluorenyl)ethyl chloroformate and reversed-phase liquid chromatography. *Analytical Chemistry*, 59(8), 1191-1195. Retrieved from [\[Link\]](#)

- Phenomenex. (n.d.). Chiral HPLC Separations.
- Fernández-Pérez, L., González-Sabin, J., & Rebolledo, F. (2006). Enzymatic resolution of trans-4-(4'-fluorophenyl)-3-hydroxymethylpiperidines, key intermediates in the synthesis of (-)-Paroxetine. *Tetrahedron: Asymmetry*, 17(12), 1815-1820. Retrieved from [[Link](#)]
- ResearchGate. (n.d.). Summary of 3,3,3-trifluorolactic acid resolution outcomes using (S)-amines (1 mmol scale). Retrieved from [[Link](#)]
- Wang, F., Wang, D., Wan, W., & Chen, P. (2019). Synthesis of α -Trifluoromethylamines by Cu-Catalyzed Regio- and Enantioselective Hydroamination of 1-Trifluoromethylalkenes. *Organic Letters*, 21(13), 5133-5137. Retrieved from [[Link](#)]
- Zhang, T., Holder, E., Franco, P., & Zhang, Y. (2014). Screening primary racemic amines for enantioseparation by derivatized polysaccharide and cyclofructan columns. *Journal of Pharmaceutical and Biomedical Analysis*, 98, 265-272. Retrieved from [[Link](#)]
- Li, W., Pan, F., Wang, S., & Song, Q. (2022). Dynamic Kinetic Resolution-Enabled Highly Stereoselective Nucleophilic Fluoroalkylation to Access Chiral β -Fluoro Amines. *Organic Letters*, 24(32), 6009-6014. Retrieved from [[Link](#)]
- Kolodiazhna, A. O., et al. (2024). Chemoenzymatic method for the synthesis of enantiomerically pure fluorine-substituted β -methylphenylethylamines. *Ukrainica Bioorganica Acta*. Retrieved from [[Link](#)]
- Denton, J. R., Sukumaran, D., & Davies, H. M. L. (2007). Enantioselective Synthesis of Trifluoromethyl-Substituted Cyclopropanes. *Organic Letters*, 9(14), 2625-2628. Retrieved from [[Link](#)]
- Iлиз, I., Aranyi, A., & Pataj, Z. (2023). Comprehensive Review on Chiral Stationary Phases in Single-Column Simultaneous Chiral–Achiral HPLC Separation Methods. *Molecules*, 28(15), 5789. Retrieved from [[Link](#)]
- Wikipedia. (n.d.). Chiral resolution. Retrieved from [[Link](#)]
- BioDuro. (2018). Diastereomeric Salt Resolution for Separating Chiral Compounds on Larger Scale at BioDuro. Retrieved from [[Link](#)]

- ResearchGate. (n.d.). Kinetic resolution of β -fluoroamines by a promiscuous hydrodefluorination-deamination process catalyzed by ATAs. Retrieved from [[Link](#)]
- Dembinski, R., et al. (2021). Enzymatic Approach to the Synthesis of Enantiomerically Pure Hydroxy Derivatives of 1,3,5-Triaza-7-phosphaadamantane. *The Journal of Organic Chemistry*, 86(13), 8979-8988. Retrieved from [[Link](#)]
- Columnex LLC. (n.d.). Chiral HPLC and SFC Columns. Retrieved from [[Link](#)]
- ResearchGate. (n.d.). Self-Disproportionation of Enantiomers of Chiral, Non-Racemic Fluoroorganic Compounds: Role of Fluorine as Enabling Element. Retrieved from [[Link](#)]
- Shayan, F., & Sanati-Nezhad, A. (2023). Chiral resolution methods for racemic pharmaceuticals based on cocrystal formation. *CrystEngComm*, 25(40), 5673-5690. Retrieved from [[Link](#)]
- Shimadzu. (2016). Chiral Separation Using SFC and HPLC. Retrieved from [[Link](#)]
- Ali, I., et al. (2021). Enantiomer Separation of Chiral Amines and Amino Acid Esters on Polysaccharide Phenylcarbamates Derived Chiral Stationary Phases. *Yakhak Hoeji*, 65(4), 256-265. Retrieved from [[Link](#)]
- Daicel Chiral Technologies. (2021). Troubleshoot Chiral Column Performance: Efficiency & Resolution. Retrieved from [[Link](#)]
- BenchChem. (n.d.). Technical Support Center: Chiral Resolution of 1-(4-Fluoro-3-methoxyphenyl)ethanamine.
- LibreTexts Chemistry. (2015). 5.8: Resolution: Separation of Enantiomers. Retrieved from [[Link](#)]
- ResearchGate. (n.d.). CRC Handbook of Optical Resolutions via Diastereomeric Salt Formation. Retrieved from [[Link](#)]
- ResearchGate. (2014). Problem With CHIRAL PAK AD-H Column - Can anyone help?. Retrieved from [[Link](#)]

- ResearchGate. (n.d.). Enzymatic resolution as a convenient method for the production of chiral resolved materials. Retrieved from [[Link](#)]
- ResearchGate. (n.d.). Enzymatic resolution of (\pm)-trans-4-(4'-fluorophenyl)-6-oxo-piperidin-3-ethyl carboxylate, an intermediate in the synthesis of (-)-Paroxetine. Retrieved from [[Link](#)]
- Bode Research Group. (n.d.). Kinetic resolution of amines. Retrieved from [[Link](#)]

Need Custom Synthesis?

BenchChem offers custom synthesis for rare earth carbides and specific isotopic labeling.

Email: info@benchchem.com or [Request Quote Online](#).

Sources

- [1. Enantioselective Synthesis of Trifluoromethyl-Substituted Cyclopropanes \[organic-chemistry.org\]](#)
- [2. researchgate.net \[researchgate.net\]](#)
- [3. pdf.benchchem.com \[pdf.benchchem.com\]](#)
- [4. Diastereomeric Salt Resolution for Separating Chiral Compounds on Larger Scale at BioDuro-BioDuro-Global CRDMO, Rooted in Science \[bioduro.com\]](#)
- [5. chem.libretexts.org \[chem.libretexts.org\]](#)
- [6. Enantiomer Separation of Chiral Amines and Amino Acid Esters on Polysaccharide Phenylcarbamates Derived Chiral Stationary Phases \[yakhak.org\]](#)
- [7. pdf.benchchem.com \[pdf.benchchem.com\]](#)
- [8. phx.phenomenex.com \[phx.phenomenex.com\]](#)
- [9. mdpi.com \[mdpi.com\]](#)
- [10. Enzymatic resolution of trans-4-\(4'-fluorophenyl\)-3-hydroxymethylpiperidines, key intermediates in the synthesis of \(-\)-Paroxetine - PubMed \[pubmed.ncbi.nlm.nih.gov\]](#)
- [11. researchgate.net \[researchgate.net\]](#)
- [12. pdfs.semanticscholar.org \[pdfs.semanticscholar.org\]](#)
- [13. Enzymatic Approach to the Synthesis of Enantiomerically Pure Hydroxy Derivatives of 1,3,5-Triaza-7-phosphaadamantane - PMC \[pmc.ncbi.nlm.nih.gov\]](#)

- [14. shimadzu.com \[shimadzu.com\]](https://www.shimadzu.com)
- [15. researchgate.net \[researchgate.net\]](https://www.researchgate.net)
- [16. Screening primary racemic amines for enantioseparation by derivatized polysaccharide and cyclofructan columns - PMC \[pmc.ncbi.nlm.nih.gov\]](https://pubmed.ncbi.nlm.nih.gov/1443849/)
- [17. pubs.acs.org \[pubs.acs.org\]](https://pubs.acs.org)
- [18. chiraltech.com \[chiraltech.com\]](https://www.chiraltech.com)
- [19. researchgate.net \[researchgate.net\]](https://www.researchgate.net)
- To cite this document: BenchChem. [Technical Support Center: Resolution of Trifluorophenylmethanamine Isomers]. BenchChem, [2026]. [Online PDF]. Available at: [\[https://www.benchchem.com/product/b1443849/docs#technical-support-center-resolution-of-trifluorophenylmethanamine-isomers\]](https://www.benchchem.com/product/b1443849/docs#technical-support-center-resolution-of-trifluorophenylmethanamine-isomers)

Disclaimer & Data Validity:

The information provided in this document is for Research Use Only (RUO) and is strictly not intended for diagnostic or therapeutic procedures. While BenchChem strives to provide accurate protocols, we make no warranties, express or implied, regarding the fitness of this product for every specific experimental setup.

Technical Support: The protocols provided are for reference purposes. Unsure if this reagent suits your experiment?

Need Industrial/Bulk Grade? [Request Custom Synthesis Quote](#)

BenchChem

Our mission is to be the trusted global source of essential and advanced chemicals, empowering scientists and researchers to drive progress in science and industry.

Contact

Address: 3281 E Guasti Rd
Ontario, CA 91761, United States
Phone: (601) 213-4426
Email: info@benchchem.com

Contact our Ph.D. Support Team for a compatibility check