

Technical Guide: Regioselective Functionalization of 4-Bromo-2-fluoro-5-methoxypyridine

Author: BenchChem Technical Support Team. **Date:** May 2026

Compound of Interest

Compound Name: 4-Bromo-2-fluoro-5-methoxypyridine
CAS No.: 1227564-33-1
Cat. No.: B1443772

[Get Quote](#)

CAS: 884495-00-5 | Formula: C₆H₅BrFNO | MW: 206.01 Support Tier: Advanced Synthesis & Troubleshooting

The Selectivity Triad: Reactivity Profile

This scaffold presents three distinct reactive sites, each activated by a specific electronic environment. Understanding this "Selectivity Triad" is critical to preventing side reactions such as halogen migration ("Halogen Dance") or regio-scrambling.

Site	Substituent	Electronic Character	Primary Reactivity Mode	Key Reagents
C2	Fluoro	Highly Activated (-deficient)	S _N Ar (Nucleophilic Aromatic Substitution)	Amines, Alkoxides, Thiols
C4	Bromo	Activated Handle	Cross-Coupling (Pd/Ni) or Li-Hal Exchange	Pd(0), n-BuLi, Grignards
C3	Proton	Acidic (Flanked by F & Br)	Deprotonation / Halogen Dance	LDA, LiTMP (Low Temp)

Troubleshooting & Protocols by Reaction Type

Module A: Nucleophilic Aromatic Substitution (S_NAr)

Target Site: C2-Position (Displacement of Fluorine)

Mechanism: The C2 position is highly electrophilic due to the adjacent ring nitrogen and the strong inductive effect of fluorine. The C4-Bromo group is significantly less reactive toward S_NAr, allowing for chemoselective substitution at C2 without disturbing the bromine handle.

Common Issues & Solutions:

Symptom	Probable Cause	Corrective Action
Low Conversion	Nucleophile is too bulky or solvent is non-polar.	Switch to polar aprotic solvents (DMSO, NMP, DMF) to stabilize the Meisenheimer complex. Use microwave irradiation (100–120°C).
Hydrolysis (C2-OH)	Wet solvent or hygroscopic base.	Use anhydrous solvents. Switch base from KOH/NaOH to DIPEA or K ₂ CO ₃ .
C4-Substitution	Harsh conditions with thiolates.	Maintain temperature <80°C. Thiolates are soft nucleophiles and can attack C4-Br; control stoichiometry strictly (1.05 eq).

Standard Protocol: C2-Amination

- Setup: Dissolve **4-Bromo-2-fluoro-5-methoxypyridine** (1.0 eq) in anhydrous DMSO (0.5 M).
- Reagent: Add amine nucleophile (1.1 eq) and DIPEA (2.0 eq).
- Reaction: Stir at 60–80°C for 4–12 hours. Monitor by LCMS.
- Workup: Dilute with water (precipitate often forms). Filter or extract with EtOAc.
 - Note: If the product is water-soluble, use n-Butanol for extraction.

Module B: Palladium-Catalyzed Cross-Coupling

Target Site: C4-Position (Displacement of Bromine)

Mechanism: Oxidative addition of Pd(0) occurs preferentially at the C4-Br bond (weaker bond energy) compared to C2-F. However, the electron-poor nature of the ring can make the C4-Pd species prone to protodebromination if the catalytic cycle is slow.

FAQ: Can I couple at C2-F?

- Answer: Generally, no. Standard Pd-catalysts (e.g., Pd(PPh₃)₄, Pd(dppf)Cl₂) will not activate the C2-F bond. To couple at C2, you typically need to displace F via S_NAr first, or use specialized Ni-catalysts designed for C-F activation (rare and difficult on this scaffold).

Troubleshooting Guide:

Issue	Diagnosis	Fix
Protodebromination (Formation of 2-fluoro-5-methoxypyridine)	Slow transmetalation or presence of moisture/acidic protons.	Switch to anhydrous conditions. Use a stronger base (Cs ₂ CO ₃) or a more active catalyst system (e.g., Pd(OAc) ₂ + SPhos) to speed up the cycle.
Homocoupling	Oxidation of the boronic acid.	Degas solvents thoroughly (sparge with Ar for 15 min).
No Reaction	Oxidative addition failure due to electron-rich ring (OMe effect).	Use electron-rich bulky phosphine ligands (e.g., XPhos, BrettPhos) to facilitate oxidative addition.

Protocol: Suzuki-Miyaura Coupling at C4

- Reactants: Substrate (1.0 eq), Boronic Acid (1.2 eq), Pd(dppf)Cl₂ (0.05 eq), K₂CO₃ (2.0 eq).
- Solvent: 1,4-Dioxane/Water (4:1). Degas thoroughly.
- Conditions: Heat to 90°C under Argon for 2–6 hours.
- Purification: Silica gel chromatography. The C2-F group usually survives these conditions intact.

Module C: Metallation & The "Halogen Dance" Risk

Target Site: C3 (Deprotonation) vs. C4 (Exchange)

Critical Warning: This substrate is prone to Halogen Dance (Base-Catalyzed Halogen Migration).

- Scenario: If you treat the substrate with LDA at -78°C , you deprotonate at C3 (between F and Br). The resulting anion is unstable and can cause the Br atom to migrate from C4 to C3, shifting the Lithium to C4.
- Result: You obtain the 3-Bromo-4-functionalized product instead of the expected 3-functionalized-4-bromo product.

Decision Matrix for Organometallics:

Desired Transformation	Reagent	Conditions	Mechanism
Functionalize C4 (Remove Br)	n-BuLi	THF, -78°C	Lithium-Halogen Exchange (Fast). Kinetic control.
Functionalize C3 (Keep Br)	LDA / LiTMP	THF, -78°C	High Risk. Must quench in situ (e.g., with TMSCl present) to prevent migration.
Functionalize C6	n-BuLi + Ligand	Unlikely	C6 is blocked by N-lone pair repulsion and OMe direction is weaker than C3 acidity.

Protocol: Selective C4-Lithiation (Exchange)

- Cooling: Cool a solution of substrate in dry THF to -78°C .
- Exchange: Add n-BuLi (1.05 eq) dropwise.
 - Tip: The exchange is extremely fast (< 5 mins). Do not stir for long periods.

- Quench: Add the electrophile (e.g., DMF, CO₂, Aldehyde) immediately.
- Warm: Allow to warm to RT slowly.

Visual Decision Tree (Graphviz)

The following diagram illustrates the divergent synthetic pathways based on reagent selection.

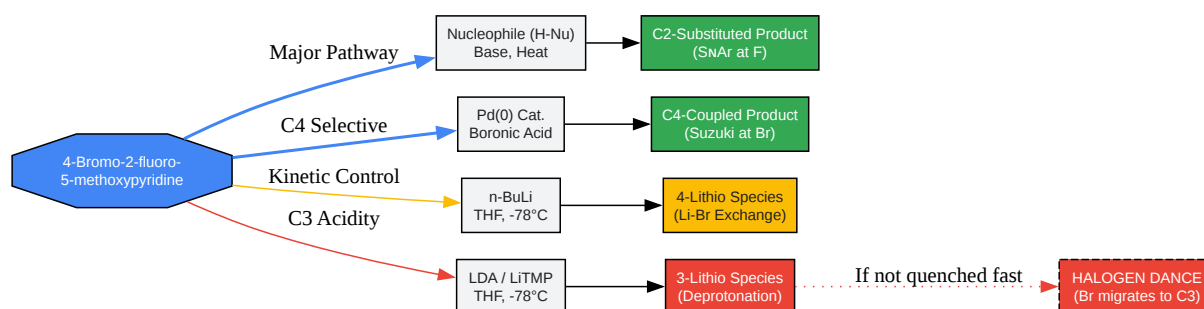

[Click to download full resolution via product page](#)

Caption: Reaction pathway divergence. Blue paths indicate standard stable transformations. Red paths indicate high-risk metallation zones prone to rearrangement.

References

- **SNAr Reactivity of 2-Fluoropyridines**
 - Title: Regioselective Nucleophilic Aromatic Substitution of 2,4-Dihalopyridines.[1][2]
 - Source: BenchChem Applic
- **Suzuki Coupling Methodology**
 - Title: Microwave-Assisted Regioselective Suzuki Coupling of 2,4-Dichloropyrimidines (Analogous reactivity).
 - Source: MDPI Molecules.

- URL:[[Link](#)][3]
- Halogen Dance Mechanism
 - Title: Halogen Dance Reactions on Heteroaromatic Systems.[4][5][6][7]
 - Source: Imperial College London / Wikipedia Summary.
 - URL:[[Link](#)]
- Compound Data
 - Title: **4-Bromo-2-fluoro-5-methoxypyridine** Chemical Properties.[8][9][10]
 - Source: PubChem / ChemicalBook.
 - URL:[[Link](#)]

Need Custom Synthesis?

BenchChem offers custom synthesis for rare earth carbides and specific isotopic labeling.

Email: info@benchchem.com or [Request Quote Online](#).

Sources

- [1. Understanding the highly variable Regioselectivity in SNAr reaction of Dichloropyrimidines - RCS Research Chemistry Services \[rcs.wuxiapptec.com\]](#)
- [2. Regioselective Nucleophilic Aromatic Substitution: Theoretical and Experimental Insights into 4-Aminoquinazoline Synthesis as a Privileged Structure in Medicinal Chemistry - PMC \[pmc.ncbi.nlm.nih.gov\]](#)
- [3. researchgate.net \[researchgate.net\]](#)
- [4. researchgate.net \[researchgate.net\]](#)
- [5. Halogen dance rearrangement - Wikipedia \[en.wikipedia.org\]](#)
- [6. eprints.whiterose.ac.uk \[eprints.whiterose.ac.uk\]](#)
- [7. ch.ic.ac.uk \[ch.ic.ac.uk\]](#)
- [8. 884495-00-5 | 4-BROMO-5-FLUORO-2-METHOXYPYRIDINE \[fluoromart.com\]](#)

- [9. PubChemLite - 4-bromo-2-fluoro-5-methoxypyridine \(C6H5BrFNO\)](#)
[\[pubchemlite.lcsb.uni.lu\]](#)
- [10. patentimages.storage.googleapis.com](#) [[patentimages.storage.googleapis.com](#)]
- To cite this document: BenchChem. [Technical Guide: Regioselective Functionalization of 4-Bromo-2-fluoro-5-methoxypyridine]. BenchChem, [2026]. [Online PDF]. Available at: [<https://www.benchchem.com/product/b1443772/docs#technical-guide-regioselective-functionalization-of-4-bromo-2-fluoro-5-methoxypyridine>]

Disclaimer & Data Validity:

The information provided in this document is for Research Use Only (RUO) and is strictly not intended for diagnostic or therapeutic procedures. While BenchChem strives to provide accurate protocols, we make no warranties, express or implied, regarding the fitness of this product for every specific experimental setup.

Technical Support: The protocols provided are for reference purposes. Unsure if this reagent suits your experiment?

Need Industrial/Bulk Grade? [Request Custom Synthesis Quote](#)

BenchChem

Our mission is to be the trusted global source of essential and advanced chemicals, empowering scientists and researchers to drive progress in science and industry.

Contact

Address: 3281 E Guasti Rd
Ontario, CA 91761, United States
Phone: (601) 213-4426
Email: info@benchchem.com

[Contact our Ph.D. Support Team for a compatibility check](#)

