

A Mechanistic Guide to Pyrrolopyrimidine Synthesis: Comparing Cyclization Strategies

Author: BenchChem Technical Support Team. **Date:** May 2026

Compound of Interest

Compound Name: *Ethyl 2-cyano-4,4-dimethoxybutanoate*

CAS No.: 773076-83-8

Cat. No.: B1441027

[Get Quote](#)

Introduction: The pyrrolopyrimidine scaffold is a privileged heterocyclic system of immense interest in medicinal chemistry and drug development.[1] Its structural resemblance to purine bases makes it an ideal framework for designing inhibitors of various kinases and other enzymes crucial in cellular signaling pathways.[2] Consequently, the development of efficient and versatile synthetic strategies to access structurally diverse pyrrolopyrimidines is a cornerstone of modern pharmaceutical research. This guide provides a comparative analysis of key cyclization strategies for constructing the pyrrolopyrimidine core, delving into the mechanistic underpinnings of each approach to empower researchers in selecting and optimizing synthetic routes. We will explore classical condensation reactions, transition-metal-catalyzed cross-couplings, and innovative multicomponent and cascade reactions, offering insights into the rationale behind experimental choices and providing actionable protocols.

Foundational Strategies: Annulation of a Pyrrole Ring onto a Pyrimidine Precursor

A prevalent and historically significant approach to pyrrolopyrimidine synthesis involves the construction of the pyrrole ring onto a pre-existing, functionalized pyrimidine core. These

methods often rely on classical condensation and cyclization reactions, offering robust and scalable routes to various isomers.

Intramolecular Cyclization of Substituted Pyrimidines

One of the most direct methods involves the intramolecular cyclization of a pyrimidine bearing a suitable side chain at an adjacent position to a reactive group. A common strategy is the cyclization of pyrimidine derivatives in an acidic medium.[3]

Mechanism: The reaction typically proceeds via the deprotection of an acetal or a similar protecting group on the side chain to reveal a carbonyl functionality. This is followed by an intramolecular condensation between the newly formed carbonyl and an adjacent amino group on the pyrimidine ring, leading to the formation of the fused pyrrole ring.

Experimental Protocol: Acid-Catalyzed Cyclization of a Pyrimidine Derivative[3]

- Dissolve the substituted pyrimidine precursor in a suitable acidic medium (e.g., a mixture of acetic acid and hydrochloric acid).
- Heat the reaction mixture under reflux for a specified period, monitoring the reaction progress by thin-layer chromatography (TLC).
- Upon completion, cool the reaction mixture and neutralize it with a suitable base (e.g., sodium bicarbonate solution).
- Extract the product with an organic solvent (e.g., ethyl acetate).
- Dry the organic layer over anhydrous sodium sulfate, filter, and concentrate under reduced pressure.
- Purify the crude product by column chromatography or recrystallization to obtain the desired pyrrolopyrimidine.

Causality Behind Experimental Choices: The choice of a strong acid is crucial for the efficient deprotection of the acetal and to catalyze the subsequent intramolecular condensation.

Refluxing provides the necessary thermal energy to overcome the activation barrier for the

cyclization reaction. The workup procedure is designed to neutralize the acid and isolate the organic product from the aqueous medium.

Diagram: Acid-Catalyzed Intramolecular Cyclization

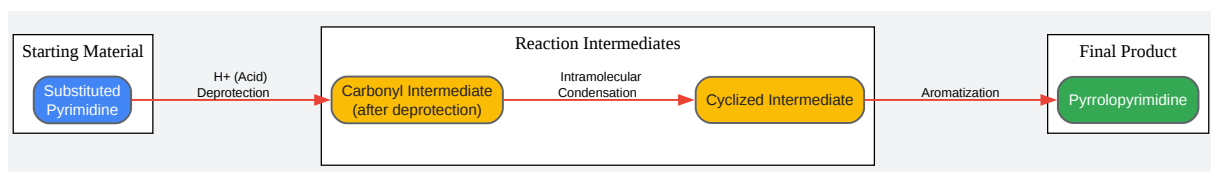

[Click to download full resolution via product page](#)

Caption: Acid-catalyzed intramolecular cyclization of a substituted pyrimidine.

Modern Synthetic Approaches: Leveraging Catalysis and Multicomponent Reactions

While classical methods are reliable, modern synthetic chemistry has introduced more sophisticated and efficient strategies for pyrrolopyrimidine synthesis, often employing transition-metal catalysis and multicomponent reactions to achieve higher complexity and diversity in a single step.

Transition-Metal-Catalyzed Cross-Coupling and Annulation

Transition metals, particularly palladium, play a pivotal role in modern organic synthesis by facilitating the formation of carbon-carbon and carbon-heteroatom bonds.[4] These methods offer high efficiency and functional group tolerance.

2.1.1. Palladium-Catalyzed Annulation

Palladium-catalyzed reactions are widely used for constructing heterocyclic systems.[5] For instance, the Buchwald-Hartwig C-N cross-coupling reaction has been optimized for the synthesis of pyrrolo[2,3-d]pyrimidine derivatives, which are potent tyrosine kinase inhibitors.[6]

Mechanism: The catalytic cycle typically involves:

- Oxidative Addition: The palladium(0) catalyst adds to a halo-substituted pyrimidine.
- Coordination: An amine (part of the pyrrole precursor) coordinates to the palladium(II) complex.
- Deprotonation: A base deprotonates the coordinated amine.
- Reductive Elimination: The C-N bond is formed, releasing the pyrrolopyrimidine product and regenerating the palladium(0) catalyst.

Experimental Protocol: Pd-Catalyzed Synthesis of a Pyrrolo[2,3-d]pyrimidine Derivative[5][7]

- To a reaction vessel, add the halo-substituted pyrimidine, the pyrrole precursor, a palladium catalyst (e.g., Pd₂(dba)₃), a phosphine ligand (e.g., Xantphos), and a base (e.g., Cs₂CO₃).
- Add a suitable anhydrous solvent (e.g., dioxane) under an inert atmosphere (e.g., argon).
- Heat the reaction mixture to the desired temperature (e.g., 100 °C) and stir for the required time, monitoring by TLC.
- After completion, cool the mixture, filter through celite, and concentrate the filtrate.
- Purify the residue by column chromatography to yield the desired product.

Causality Behind Experimental Choices: The choice of catalyst, ligand, and base is critical for the reaction's success. The ligand stabilizes the palladium catalyst and modulates its reactivity. The base is necessary to facilitate the deprotonation of the amine, a key step in the catalytic cycle. The inert atmosphere prevents the oxidation and deactivation of the palladium(0) catalyst.

Diagram: Palladium-Catalyzed C-N Cross-Coupling

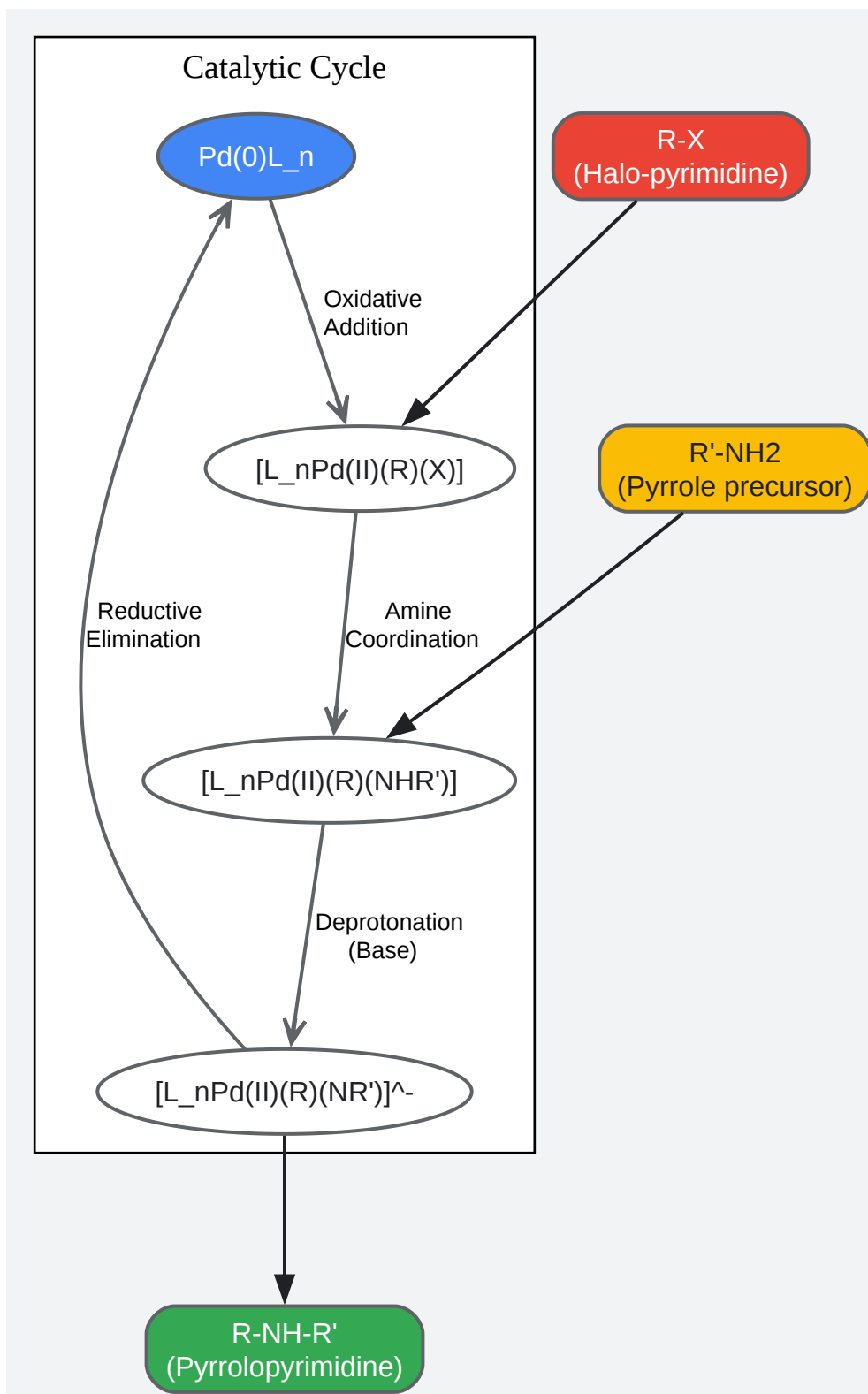

[Click to download full resolution via product page](#)

Caption: Simplified catalytic cycle for Pd-catalyzed C-N cross-coupling.

Multicomponent Reactions (MCRs)

Multicomponent reactions offer a highly efficient approach to synthesizing complex molecules like pyrrolopyrimidines in a single step from three or more starting materials.^[8] This strategy is advantageous for building molecular diversity and is often more atom-economical than traditional multi-step syntheses.

Example: Three-Component Synthesis of Pyrrolo[2,3-d]pyrimidines^[8]

A one-pot, three-component reaction of arylglyoxals, 6-amino-1,3-dimethyluracil, and barbituric acid derivatives can be used to synthesize polyfunctionalized pyrrolo[2,3-d]pyrimidines.^[8]

Mechanism: The reaction likely proceeds through a series of condensation and cyclization steps. The initial step is a Knoevenagel condensation between the arylglyoxal and the active methylene compound (barbituric acid derivative). The resulting adduct then reacts with the 6-aminouracil, followed by an intramolecular cyclization and dehydration to form the final pyrrolopyrimidine product.

Experimental Protocol: Three-Component Synthesis^[8]

- In a reaction flask, combine the arylglyoxal, 6-amino-1,3-dimethyluracil, and the barbituric acid derivative in a suitable solvent (e.g., ethanol).
- Add a catalytic amount of a phase-transfer catalyst like tetra-n-butylammonium bromide (TBAB).
- Heat the mixture at a moderate temperature (e.g., 50 °C) for a few hours.
- Monitor the reaction by TLC. Upon completion, cool the mixture to induce precipitation of the product.
- Filter the solid, wash with a cold solvent, and dry to obtain the pure pyrrolopyrimidine derivative.

Causality Behind Experimental Choices: The use of a catalyst like TBAB can enhance the reaction rate and yield. Ethanol is a green and effective solvent for this transformation. The

moderate reaction temperature is often sufficient to drive the reaction to completion without promoting side reactions.

Diagram: Three-Component Reaction Workflow

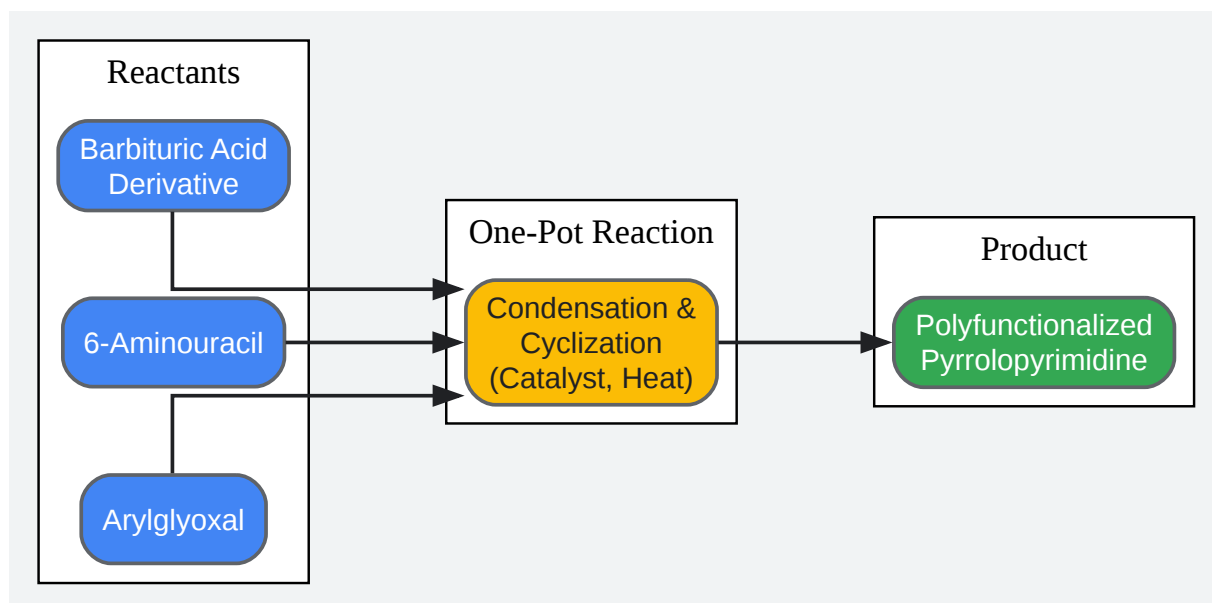

[Click to download full resolution via product page](#)

Need Custom Synthesis?

BenchChem offers custom synthesis for rare earth carbides and specific isotopic labeling.

Email: info@benchchem.com or [Request Quote Online](#).

Sources

- [1. researchgate.net \[researchgate.net\]](https://www.researchgate.net)
- [2. Pyrrolo\[2,3-d\]pyrimidines as potential kinase inhibitors in cancer drug discovery: A critical review - PubMed \[pubmed.ncbi.nlm.nih.gov\]](https://pubmed.ncbi.nlm.nih.gov/)
- [3. catalog.journals4promo.com \[catalog.journals4promo.com\]](https://www.catalog.journals4promo.com)
- [4. mdpi.com \[mdpi.com\]](https://www.mdpi.com)
- [5. Pyrrolopyrimidines: Design, Synthesis and Antitumor Properties of Novel Tricyclic Pyrrolo \[2,3-d\]pyrimidine Derivatives - PMC \[pmc.ncbi.nlm.nih.gov\]](https://pubmed.ncbi.nlm.nih.gov/)

- [6. The synthesis and bioactivity of pyrrolo\[2,3-d\]pyrimidine derivatives as tyrosine kinase inhibitors for NSCLC cells with EGFR mutations - PubMed \[pubmed.ncbi.nlm.nih.gov\]](#)
- [7. mdpi.com \[mdpi.com\]](#)
- [8. One-pot, three-component Synthesis of pyrrolo\[2,3-d\]pyrimidine Derivatives \[scielo.org.mx\]](#)
- To cite this document: BenchChem. [A Mechanistic Guide to Pyrrolopyrimidine Synthesis: Comparing Cyclization Strategies]. BenchChem, [2026]. [Online PDF]. Available at: [\[https://www.benchchem.com/product/b1441027/docs#a-mechanistic-guide-to-pyrrolopyrimidine-synthesis-comparing-cyclization-strategies\]](https://www.benchchem.com/product/b1441027/docs#a-mechanistic-guide-to-pyrrolopyrimidine-synthesis-comparing-cyclization-strategies)

Disclaimer & Data Validity:

The information provided in this document is for Research Use Only (RUO) and is strictly not intended for diagnostic or therapeutic procedures. While BenchChem strives to provide accurate protocols, we make no warranties, express or implied, regarding the fitness of this product for every specific experimental setup.

Technical Support: The protocols provided are for reference purposes. Unsure if this reagent suits your experiment?

Need Industrial/Bulk Grade? [Request Custom Synthesis Quote](#)

BenchChem

Our mission is to be the trusted global source of essential and advanced chemicals, empowering scientists and researchers to drive progress in science and industry.

Contact

Address: 3281 E Guasti Rd
Ontario, CA 91761, United States
Phone: (601) 213-4426
Email: info@benchchem.com

Contact our Ph.D. Support Team for a compatibility check