

A Comparative Guide to the Mass Spectrometry Fragmentation of Chloropyrimidine Derivatives

Author: BenchChem Technical Support Team. **Date:** May 2026

Compound of Interest

Compound Name: 4-Chloro-5-(pyridin-4-yl)pyrimidine

Cat. No.: B11781658

[Get Quote](#)

This guide provides an in-depth analysis of the mass spectrometric fragmentation behavior of chloropyrimidine derivatives. Designed for researchers, scientists, and professionals in drug development, it compares common ionization and fragmentation techniques, explains the causality behind fragmentation pathways, and offers practical, data-driven insights for structural elucidation.

Introduction: The Significance of Chloropyrimidines and Mass Spectrometry

Chloropyrimidines are a critical class of heterocyclic compounds, forming the structural core of numerous pharmaceuticals, agrochemicals, and materials. Their biological activity is often modulated by the substitution pattern on the pyrimidine ring. In drug discovery, for instance, chloropyrimidines can act as covalent inhibitors by reacting with cysteine residues in target proteins through a nucleophilic aromatic substitution (S_NAr) reaction, where the chlorine atom serves as a leaving group.[1]

Understanding the precise structure, substitution pattern, and metabolic fate of these molecules is paramount. Mass spectrometry (MS) is an indispensable tool for this purpose, offering unparalleled sensitivity and structural information from minimal sample amounts. This

guide focuses on the fragmentation patterns of chloropyrimidines under two major ionization regimes: Electron Ionization (EI) and Collision-Induced Dissociation (CID) following Electrospray Ionization (ESI).

Ionization Techniques: A Comparative Overview

The choice of ionization technique fundamentally dictates the type of information obtained from a mass spectrometry experiment. The primary distinction lies between "hard" and "soft" ionization methods.

- **Electron Ionization (EI):** A classic, hard ionization technique where high-energy electrons (typically 70 eV) bombard the analyte molecule in the gas phase.^{[2][3]} This process imparts significant internal energy, leading to the formation of a radical cation ($M^{\bullet+}$) and subsequent, often extensive, fragmentation.^{[2][4]} While this extensive fragmentation can sometimes prevent the observation of the molecular ion for labile compounds, it produces a reproducible "fingerprint" spectrum rich in structural information.^{[2][5]}
- **Electrospray Ionization (ESI):** A soft ionization technique ideal for polar, thermally labile, and high-molecular-weight compounds.^{[3][6]} ESI generates protonated molecules, $[M+H]^+$, or other adducts in the solution phase, which are then transferred to the gas phase. This gentle process typically preserves the molecular ion, yielding minimal in-source fragmentation.^[7] To induce fragmentation for structural analysis, ESI is almost always coupled with tandem mass spectrometry (MS/MS), where the $[M+H]^+$ ion is selectively isolated and fragmented via Collision-Induced Dissociation (CID).^[8]

Feature	Electron Ionization (EI)	Electrospray Ionization (ESI) with CID
Ionization Principle	High-energy electron bombardment in gas phase.[2]	Nebulization and desolvation of charged droplets from solution.[6]
Primary Ion Formed	Radical Cation ($M^{\bullet+}$).[2]	Protonated Molecule ($[M+H]^+$). [7]
Fragmentation	Extensive, occurs in the ion source.	Controlled, occurs in a collision cell (MS/MS).[8]
Molecular Ion Peak	May be weak or absent for some compounds.	Typically the base peak in the MS1 spectrum.
Typical Analytes	Volatile, thermally stable, smaller molecules.	Polar, non-volatile, large and small molecules.
Key Application	Library matching, structural fingerprinting.	Analysis of complex mixtures (LC-MS), targeted quantification.[9]

Fragmentation Pathways under Electron Ionization (EI)

Under EI conditions, the fragmentation of chloropyrimidines is initiated from the molecular radical cation ($M^{\bullet+}$). The pathways are generally predictable and provide key structural clues.

Characteristic EI Fragmentations of 2-Chloropyrimidine

The fragmentation of the parent 2-chloropyrimidine serves as a foundational example. The primary fragmentation events involve the loss of the chlorine atom and cleavage of the pyrimidine ring.

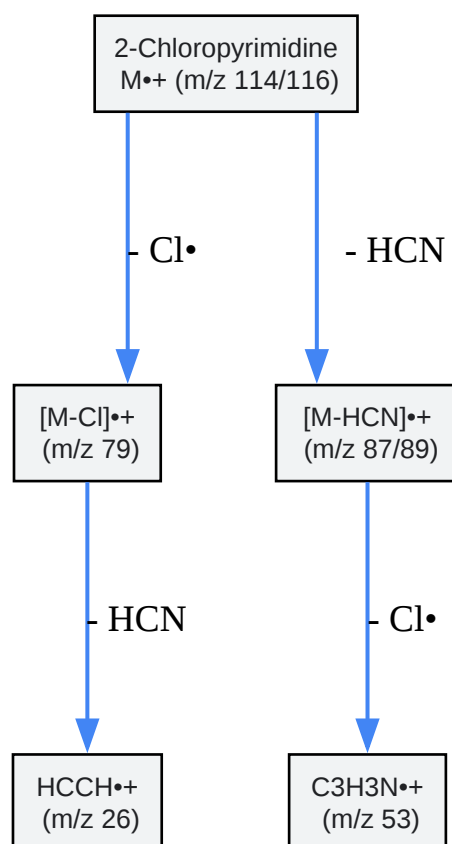

[Click to download full resolution via product page](#)

Caption: Key EI fragmentation pathways for 2-chloropyrimidine.

Mechanistic Insights:

- Loss of Chlorine Radical ($-Cl^{\bullet}$): The cleavage of the C-Cl bond is a facile process, leading to the formation of the pyrimidine cation at m/z 79. This is often a prominent peak.
- Loss of Hydrogen Cyanide ($-HCN$): A characteristic fragmentation for nitrogen-containing heterocycles is the elimination of a neutral HCN molecule. For 2-chloropyrimidine, this results in an ion at m/z 87 (and its ^{37}Cl isotope at m/z 89).
- Ring Cleavage: More energetic fragmentation leads to the breakdown of the pyrimidine ring itself. The formation of fragments like $C_3H_3N^{\bullet+}$ (m/z 53) and $HCCH^{\bullet+}$ (m/z 26) are indicative of ring scission.^[10] The site of halogenation can influence the relative abundance of these fragments.^[11]

Fragmentation Pathways via Collision-Induced Dissociation (CID)

In ESI-MS/MS, the protonated molecule $[M+H]^+$ is selectively isolated and subjected to collisions with an inert gas (e.g., argon or nitrogen) to induce fragmentation.[8] This controlled process provides highly specific structural information. For substituted chloropyrimidines, the fragmentation is heavily influenced by the nature and position of the substituents.

General CID Pathways for Substituted Chloropyrimidines

The protonation site is a key determinant of the subsequent fragmentation cascade. Pyrimidine rings typically protonate on one of the ring nitrogens.[7]

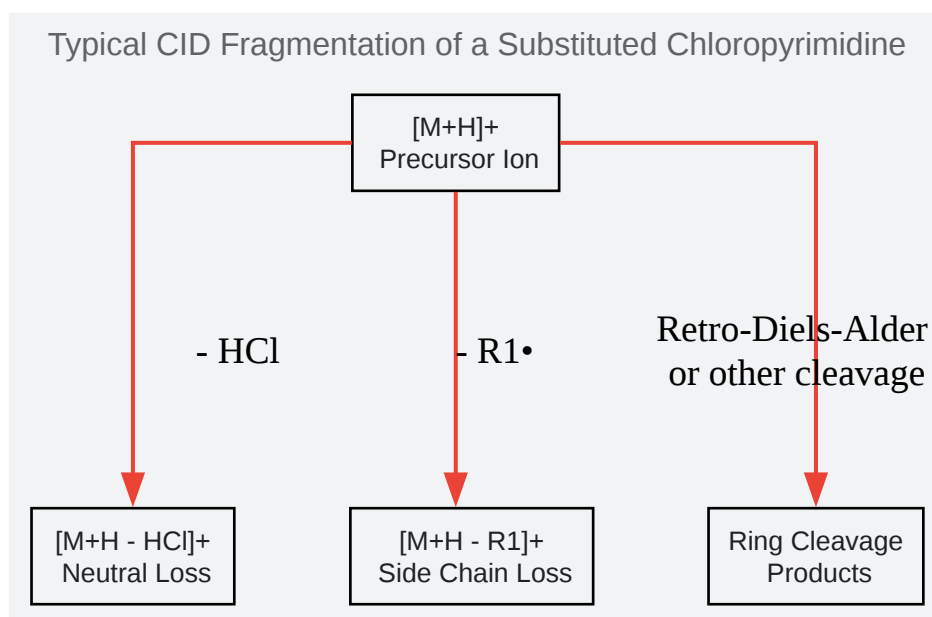

[Click to download full resolution via product page](#)

Caption: Generalized CID fragmentation pathways for protonated chloropyrimidines.

Mechanistic Insights:

- Neutral Loss of HCl: The elimination of hydrogen chloride is a very common and diagnostically useful pathway. This is often observed as a major fragment ion and indicates

the presence of a chlorine substituent.

- **Side-Chain Losses:** Fragmentation is often directed by substituents. The loss of side chains (R-groups) as neutral molecules or radicals is a primary pathway that helps to identify and locate these groups. Studies on various pyrimidine derivatives show that fragmentation often involves the elimination of side functional groups first, followed by the decomposition of the heterocyclic ring.[12]
- **Ring Stability and Cleavage:** The pyrimidine ring itself is relatively stable. Therefore, fragmentation pathways that preserve the ring structure, such as neutral losses, are often favored at lower collision energies.[12] At higher energies, characteristic ring cleavages can occur. For pyrimidine nucleosides, for example, a primary fragmentation is the cleavage of the glycosidic bond.[13][14]

Comparative Data: CID of Isomeric Aminochloropyrimidines

The position of substituents dramatically alters fragmentation patterns, allowing for isomer differentiation. Consider the hypothetical CID spectra of two isomeric aminodichloropyrimidines.

Precursor Ion (m/z 162)	Major Product Ion (m/z)	Proposed Neutral Loss	Rationale
4-amino-2,6-dichloropyrimidine	126	HCl	Facile loss of HCl is a dominant pathway for chloro-substituted heterocycles.
99	HCl + HCN	Subsequent loss of HCN from the pyrimidine ring is a common secondary fragmentation.	
2-amino-4,6-dichloropyrimidine	126	HCl	Loss of HCl is also a primary pathway for this isomer.
145	NH ₃	Loss of ammonia from the amino group can be a competing pathway, potentially more favorable depending on protonation site, offering a way to distinguish it from the 4-amino isomer.	

This table is illustrative, based on established fragmentation principles. Actual relative intensities depend on experimental conditions.

Experimental Protocol: Acquiring a CID Spectrum

This section outlines a self-validating protocol for obtaining a reliable CID spectrum of a novel chloropyrimidine derivative using a triple quadrupole or ion trap mass spectrometer.

Objective: To generate a reproducible product ion spectrum from the protonated molecule ($[M+H]^+$) to enable structural elucidation.

Workflow Diagram

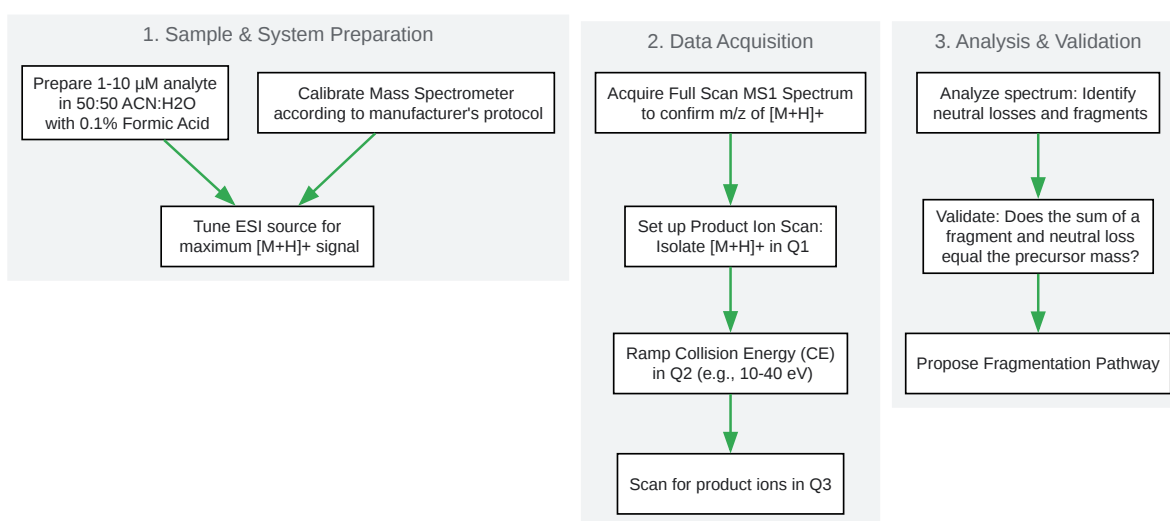

[Click to download full resolution via product page](#)

Caption: General experimental workflow for CID analysis of a chloropyrimidine.

Step-by-Step Methodology

- System Suitability:
 - Rationale: Ensuring the instrument is performing optimally is critical for data quality.
 - Action: Infuse a known standard (e.g., reserpine) and verify mass accuracy, resolution, and sensitivity meet specifications.

- Analyte Infusion and MS1 Acquisition:
 - Rationale: To find the optimal source conditions for the analyte and confirm the mass of the precursor ion. Formic acid is added to promote protonation.
 - Action: Infuse the chloropyrimidine sample solution (~5 $\mu\text{L}/\text{min}$) into the ESI source. Acquire a full scan (MS1) spectrum. The $[\text{M}+\text{H}]^+$ ion should be the base peak. Note the characteristic isotopic pattern for chlorine ($^{35}\text{Cl}/^{37}\text{Cl}$ ratio of ~3:1).
- Product Ion (MS/MS) Scan Setup:
 - Rationale: This is the core fragmentation experiment.
 - Action: Create a new experiment. Select "Product Ion Scan" or "MS/MS" mode. Enter the m/z of the monoisotopic $[\text{M}+\text{H}]^+$ ion as the precursor mass for isolation.
- Collision Energy Optimization:
 - Rationale: Collision energy (CE) is the most critical parameter for CID.[8] Too low, and no fragmentation occurs; too high, and only small, non-specific fragments are produced (the molecule "shatters"). Ramping the CE in a single experiment provides a comprehensive view of the entire fragmentation cascade.
 - Action: Set the collision gas (Argon or Nitrogen) pressure according to the manufacturer's recommendation. Instead of a single CE value, set up a collision energy ramp (e.g., from 10 to 40 eV). This allows for the capture of both low-energy (e.g., simple neutral losses) and high-energy (e.g., ring cleavage) fragments in one acquisition.
- Data Analysis and Interpretation:
 - Rationale: The final step is to interpret the resulting spectrum to deduce the structure.
 - Action: Examine the product ion spectrum. Calculate the mass differences between the precursor ion and the major fragment ions. These differences correspond to neutral losses (e.g., 36 Da for HCl). Propose structures for the major fragments and ensure they are chemically plausible. The self-validating step is to confirm that the observed fragments can be logically derived from the precursor structure.

Conclusion

The mass spectrometric fragmentation of chloropyrimidine derivatives is a systematic process governed by the principles of ion chemistry. A logical approach, beginning with the choice of an appropriate ionization technique, allows for the controlled generation of structurally significant fragment ions. Under EI, fragmentation proceeds from a radical cation, providing a characteristic fingerprint. Under ESI-CID, fragmentation of the protonated molecule is highly specific and can be controlled by varying collision energy, enabling detailed structural analysis and isomer differentiation. By understanding the core fragmentation pathways—such as the loss of HCl, side-chain cleavages, and characteristic ring fissions—researchers can confidently elucidate the structures of novel chloropyrimidine compounds, a critical task in modern drug development and chemical research.

References

- Kamel, A. M., & Munson, B. (2007). Collisionally-induced dissociation of substituted pyrimidine antiviral agents: mechanisms of ion formation using gas phase hydrogen/deuterium exchange and electrospray ionization tandem mass spectrometry. *Journal of the American Society for Mass Spectrometry*, 18(8), 1477-92. [[Link](#)]
- Limbach, P. A., Crain, P. F., & McCloskey, J. A. (1995). Cross-Section Calculations for Electron-Impact Ionization of Pyrimidine Molecule and Its Halogenated Derivatives. *Journal of the American Society for Mass Spectrometry*, 6(1), 27-39. [[Link](#)]
- Castrovilli, M. C., Bolognesi, P., Cartoni, A., Catone, D., O'Keeffe, P., Casavola, A. R., Turchini, S., Zema, N., & Avaldi, L. (2014). Photofragmentation of halogenated pyrimidine molecules in the VUV range. *Journal of the American Society for Mass Spectrometry*, 25(3), 351-67. [[Link](#)]
- Timsit, Y., et al. (2022). Discovery and Characterization of a Novel Series of Chloropyrimidines as Covalent Inhibitors of the Kinase MSK1. *Journal of Medicinal Chemistry*, 65(13), 9094-9111. [[Link](#)]
- Ojha, V., & Kumar, D. (2010). Mass spectral fragmentation modes of pyrimidine derivatives. *Rasayan Journal of Chemistry*, 3(4), 713-718. [[Link](#)]

- Salem, M. A. I., Ali, T. E., Marzouk, M. I., Salem, M. S., & Al-Shibani, G. A. (2014). Mass Spectral Fragmentation Modes of Some New Pyrimidinethiones, Thiazolo[3,2-a]Pyrimidines and Bis-Pyrimidines. *International Journal of Materials and Chemistry*, 4(4), 92-99. [[Link](#)]
- Jensen, S. S., Ariza, X., Nielsen, P., Vilarrasa, J., & Kirpekar, F. (2007). Collision-induced dissociation of cytidine and its derivatives. *Journal of Mass Spectrometry*, 42(1), 49-57. [[Link](#)]
- Cartoni, A., et al. (2012). Insights into 2-Chloropyrimidine fragmentation through a thermochemical analysis of the ionic fragments. *The Journal of Physical Chemistry A*, 116(12), 3122-3129. [[Link](#)]
- Wikipedia contributors. (2023). Collision-induced dissociation. Wikipedia, The Free Encyclopedia. [[Link](#)]
- Smyth, W. F. (2006). Recent studies on the electrospray ionisation mass spectrometric behaviour of selected nitrogen containing drug molecules and its application to drug analysis using LC-ESI-MS. *Current Pharmaceutical Analysis*, 2(1), 65-99. [[Link](#)]
- Van Bramer, S. (2022). 3.1: Electron Ionization. Chemistry LibreTexts. [[Link](#)]
- Fiehn, O. (n.d.). MS/MS fragmentation. Fiehn Lab. [[Link](#)]
- G-Biosciences. (2020). Spotting Fragmentation Patterns When Using Mass Spectrometry. G-Biosciences Blog. [[Link](#)]
- Emory University. (n.d.). Mass Spectrometry Ionization Methods. Chemistry at Emory. [[Link](#)]
- ResearchGate. (n.d.). The mass spectra of pyrimidine measured in coincidence with resonant... [[Link](#)]
- Chen, Y., et al. (2025). Interesting signals from (electro)chemical mass spectrometry: are they real?. ChemRxiv. [[Link](#)]
- Verhoeven, S., et al. (2020). Predicting Collision-Induced-Dissociation Tandem Mass Spectra (CID-MS/MS) Using Ab Initio Molecular Dynamics. *Journal of Chemical Information and Modeling*, 60(12), 6433-6445. [[Link](#)]

- Davis, W. (2013). Introduction to Ionization and Fragmentation in Mass Spectrometry. YouTube. [[Link](#)]
- Nagy, G., et al. (2021). Characterization of Anticancer Drug Protomers Using Electrospray Ionization and Ion Mobility Spectrometry–Mass Spectrometry. *Analytical Chemistry*, 93(4), 2588-2595. [[Link](#)]
- Moore, J. M., et al. (2007). An electrospray ionisation tandem mass spectrometric investigation of selected psychoactive pharmaceuticals and its application in drug and metabolite profiling by liquid chromatography/electrospray ionisation tandem mass spectrometry. *Rapid Communications in Mass Spectrometry*, 21(12), 1989-2002. [[Link](#)]

Need Custom Synthesis?

BenchChem offers custom synthesis for rare earth carbides and specific isotopic labeling.

Email: info@benchchem.com or [Request Quote Online](#).

Sources

- [1. Discovery and Characterization of a Novel Series of Chloropyrimidines as Covalent Inhibitors of the Kinase MSK1 - PMC \[pmc.ncbi.nlm.nih.gov\]](#)
- [2. chem.libretexts.org \[chem.libretexts.org\]](#)
- [3. Mass Spectrometry Ionization Methods \[chemistry.emory.edu\]](#)
- [4. youtube.com \[youtube.com\]](#)
- [5. chemrxiv.org \[chemrxiv.org\]](#)
- [6. researchgate.net \[researchgate.net\]](#)
- [7. fulir.irb.hr \[fulir.irb.hr\]](#)
- [8. Collision-induced dissociation - Wikipedia \[en.wikipedia.org\]](#)
- [9. analyticalsciencejournals.onlinelibrary.wiley.com \[analyticalsciencejournals.onlinelibrary.wiley.com\]](#)
- [10. researchgate.net \[researchgate.net\]](#)
- [11. Photofragmentation of halogenated pyrimidine molecules in the VUV range - PubMed \[pubmed.ncbi.nlm.nih.gov\]](#)

- [12. article.sapub.org \[article.sapub.org\]](https://article.sapub.org)
- [13. Collisionally-induced dissociation of substituted pyrimidine antiviral agents: mechanisms of ion formation using gas phase hydrogen/deuterium exchange and electrospray ionization tandem mass spectrometry - PubMed \[pubmed.ncbi.nlm.nih.gov\]](#)
- [14. Collision-induced dissociation of cytidine and its derivatives - PubMed \[pubmed.ncbi.nlm.nih.gov\]](#)
- To cite this document: BenchChem. [A Comparative Guide to the Mass Spectrometry Fragmentation of Chloropyrimidine Derivatives]. BenchChem, [2026]. [Online PDF]. Available at: [<https://www.benchchem.com/product/b11781658/docs#a-comparative-guide-to-the-mass-spectrometry-fragmentation-of-chloropyrimidine-derivatives>]

Disclaimer & Data Validity:

The information provided in this document is for Research Use Only (RUO) and is strictly not intended for diagnostic or therapeutic procedures. While BenchChem strives to provide accurate protocols, we make no warranties, express or implied, regarding the fitness of this product for every specific experimental setup.

Technical Support: The protocols provided are for reference purposes. Unsure if this reagent suits your experiment?

Need Industrial/Bulk Grade? [Request Custom Synthesis Quote](#)

BenchChem

Our mission is to be the trusted global source of essential and advanced chemicals, empowering scientists and researchers to drive progress in science and industry.

Contact

Address: 3281 E Guasti Rd
Ontario, CA 91761, United States
Phone: (601) 213-4426
Email: info@benchchem.com

Contact our Ph.D. Support Team for a compatibility check