

# Technical Support Center: Optimizing 2-Bromo-6-cyanopyrazine Reactivity

**Author:** BenchChem Technical Support Team. **Date:** May 2026

## Compound of Interest

Compound Name: 2-Bromo-6-cyanopyrazine

CAS No.: 859064-02-1

Cat. No.: B1440216

[Get Quote](#)

Ticket Status: OPEN Subject: Reactivity Modulation via Base & Solvent Selection Applicable Substrates: **2-Bromo-6-cyanopyrazine** (CAS: 56423-63-3 analogs), 3,6-Dichloropyrazine-2-carbonitrile. Support Level: Tier 3 (Senior Application Scientist)

## Executive Summary: The "Push-Pull" Dynamic

Welcome to the technical guide for **2-Bromo-6-cyanopyrazine**. This substrate is a critical intermediate, most notably in the synthesis of Favipiravir (T-705). Its reactivity is defined by a specific electronic tension:

- The "Pull" (Activation): The pyrazine ring is inherently electron-deficient (para-nitrogen atoms). The cyano group (-CN) at the C6 position further depletes electron density, making the C2-Bromine highly susceptible to Nucleophilic Aromatic Substitution (S<sub>N</sub>Ar).
- The "Fragility" (Risk): The same electron-withdrawing cyano group is highly prone to hydrolysis (to carboxamide or acid) in the presence of water and base.

Your Goal: Maximize

at the C2-Br site while suppressing attack at the C6-CN site.

## Module 1: Solvent Selection (The Environment)

The choice of solvent dictates the reaction rate and the specific side-reaction profile.

### Polar Aprotic Solvents (DMSO, DMF, NMP)

- Role: These are the "Standard of Care" for on pyrazines. They solvate cations (e.g., from ), leaving the nucleophile "naked" and highly reactive.
- Critical Risk: These solvents are hygroscopic. At temperatures  $>80^{\circ}\text{C}$  (common for fluorination or difficult aminations), even trace water (500-1000 ppm) will cause rapid hydrolysis of the nitrile to 2-bromo-6-pyrazinecarboxamide.
- Recommendation: Use anhydrous grades ( $<50$  ppm ). Store over molecular sieves ( $4\text{\AA}$ ).

### Protic Solvents (MeOH, EtOH, IPA)

- Role: Useful for mild aminations with highly reactive amines (e.g., primary aliphatic amines).
- Critical Risk: Solvolysis. The solvent itself can act as a nucleophile, leading to alkoxy-substituted byproducts (e.g., 2-methoxy-6-cyanopyrazine) if the base is strong enough to deprotonate the alcohol.
- Recommendation: Only use if the amine nucleophile is significantly more reactive than the solvent. Avoid strong bases (alkoxides).[1]

### Non-Polar / Low Polarity (Toluene, DCM)

- Role: Generally poor solubility for pyrazine salts. Used only with Phase Transfer Catalysts (PTC) like TBAB or 18-Crown-6.

## Module 2: Base Selection (The Activator)

Selecting the wrong base is the most common cause of "Ticket #1: Unwanted Hydrolysis."

### Inorganic Carbonates ( , )

- Application: Standard for phenols, thiols, and weak amines.
- Mechanism: Acts as an acid scavenger.

is superior in DMF due to the "Cesium Effect" (higher solubility/dissociation).

- Warning: Generates

if water is present (

). This hydroxide will attack the nitrile.

### Tertiary Amines (TEA, DIPEA)

- Application: Ideal for aminations.
- Mechanism: Soluble organic bases that scavenge HBr.
- Benefit: Non-nucleophilic (usually) and does not generate hydroxide ions directly.
- Warning: Can form quaternary ammonium salts if the reaction temperature is too high (>100°C) and the alkyl halide is reactive.

### Metal Fluorides (KF, CsF)

- Application: specifically for Halex reactions (Cl/Br

F exchange).

- Note: In Favipiravir synthesis, KF acts as the reagent. No external base is usually added, but the quality of KF (spray-dried vs. calcined) is critical to avoid moisture introduction.

## Module 3: Visualizing the Reactivity Landscape

The following diagram illustrates the decision pathways and failure modes.

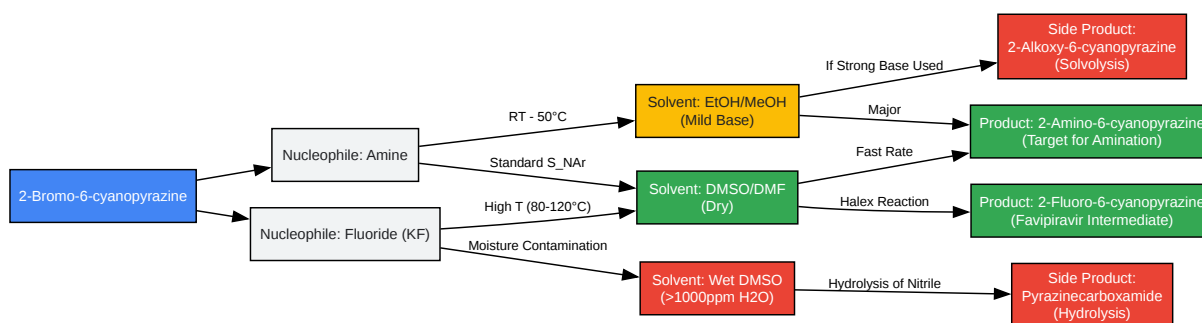

[Click to download full resolution via product page](#)

Figure 1: Reaction pathway logic showing the competition between successful substitution ( ) and hydrolysis/solvolysis side reactions.

## Module 4: Validated Protocols

### Protocol A: Fluorination (Favipiravir Intermediate)

Context: Converting 2-bromo (or chloro)-6-cyanopyrazine to the fluoro-analog.

- Preparation: Dry KF (Spray-dried) in a vacuum oven at 140°C for 4 hours.
- Solvent: Anhydrous DMSO (Water < 50 ppm).
- Setup: Inert atmosphere ( or Ar) is mandatory.
- Reaction: Combine Substrate (1.0 eq) + KF (2.0 - 4.0 eq) + 18-Crown-6 (0.1 eq, optional catalyst).

- Temp: Heat to 80-100°C.
- Checkpoint: Monitor via HPLC. If "Amide" peak (Hydrolysis) grows >5%, stop and check solvent dryness.
- Workup: Do not use aqueous acidic workup immediately if the product is acid-sensitive. Extract with EtOAc/Brine.

## Protocol B: Amination ( )

Context: Installing an amine at C2.

- Base: DIPEA (2.0 eq). Avoid inorganic bases if possible to minimize water generation.
- Solvent: THF or DMF (if solubility is an issue).
- Temp: 0°C to RT. The C2-Br is highly reactive; heat is rarely needed for primary amines.
- Process: Add amine dropwise to the solution of pyrazine + base to avoid local heating (exothermic).

## Module 5: Troubleshooting Matrix (FAQ)

Issue	Symptom (LCMS/NMR)	Root Cause	Corrective Action
Hydrolysis	Mass +18 (Amide) or +19 (Acid)	Wet solvent + Basic conditions.	Switch to anhydrous DMF/DMSO. Use molecular sieves. Reduce reaction temp.
Solvolysis	Mass +31 (Methoxy) or +45 (Ethoxy)	Reaction in alcohol with strong base.	Switch to aprotic solvent (THF, DCM) or use a weaker base (DIPEA instead of NaOEt).
Stalled Reaction	Starting material remains.	Fluoride source (KF) has "caked" or low solubility.	Use "Spray-dried" KF. Add Phase Transfer Catalyst (18-Crown-6 or TBAB).
Decomposition	Black tar / multiple peaks.	Temperature too high; Polymerization of nitrile.	Lower temperature. Ensure inert atmosphere to prevent oxidation.

## References

- Favipiravir Synthesis & Fluorination
  - Title: The complete synthesis of favipiravir from 2-aminopyrazine.[2]
  - Source: Chemical Papers (2019).[2]
  - Relevance: Details the conversion of 3,6-dichloropyrazine-2-carbonitrile to the fluoro-intermediate using KF in DMSO and the hydrolysis risks.
  - [2]
- Nucleophilic Aromatic Substitution Mechanisms

- Title: Nucleophilic Aromatic Substitution (S<sub>N</sub>Ar).[3][4]
- Source: Chemistry LibreTexts.
- Relevance: Foundational theory on electron-deficient rings and leaving group effects.
- Hydrolysis of Nitriles
  - Title: The Hydrolysis of Nitriles.[5][6][7]
  - Source: Chemistry LibreTexts.
  - Relevance: Explains the mechanism of base-c
- Patent Literature (Process Chemistry)
  - Title: Synthesis method of Favipiravir intermedi
  - Source: Google P
  - Relevance: Provides industrial conditions for the fluorin

### *Need Custom Synthesis?*

*BenchChem offers custom synthesis for rare earth carbides and specific isotopic labeling.*

*Email: [info@benchchem.com](mailto:info@benchchem.com) or [Request Quote Online](#).*

## Sources

- [1. S<sub>N</sub>Ar Reaction in Other Common Molecular Solvents - Wordpress \[reagents.acsgcivr.org\]](#)
- [2. researchgate.net \[researchgate.net\]](#)
- [3. youtube.com \[youtube.com\]](#)
- [4. byjus.com \[byjus.com\]](#)
- [5. chem.libretexts.org \[chem.libretexts.org\]](#)
- [6. chemistry.stackexchange.com \[chemistry.stackexchange.com\]](#)
- [7. US5756750A - Continuous processes for the hydrolysis of cyanopyridines under substantially adiabatic conditions - Google Patents \[patents.google.com\]](#)
- To cite this document: BenchChem. [Technical Support Center: Optimizing 2-Bromo-6-cyanopyrazine Reactivity]. BenchChem, [2026]. [Online PDF]. Available at:

[<https://www.benchchem.com/product/b1440216/docs#technical-support-center-optimizing-2-bromo-6-cyanopyrazine-reactivity>]

### Disclaimer & Data Validity:

The information provided in this document is for Research Use Only (RUO) and is strictly not intended for diagnostic or therapeutic procedures. While BenchChem strives to provide accurate protocols, we make no warranties, express or implied, regarding the fitness of this product for every specific experimental setup.

**Technical Support:** The protocols provided are for reference purposes. Unsure if this reagent suits your experiment?

**Need Industrial/Bulk Grade?** [Request Custom Synthesis Quote](#)

## BenchChem

Our mission is to be the trusted global source of essential and advanced chemicals, empowering scientists and researchers to drive progress in science and industry.

### Contact

Address: 3281 E Guasti Rd  
Ontario, CA 91761, United States  
Phone: (601) 213-4426  
Email: [info@benchchem.com](mailto:info@benchchem.com)

[Contact our Ph.D. Support Team for a compatibility check](#)