

Introduction: The Significance of the Arylpiperazine Scaffold

Author: BenchChem Technical Support Team. **Date:** May 2026

Compound of Interest

Compound Name: *N*-(3-methoxyphenyl)piperazine

CAS No.: 16015-70-6

Cat. No.: B174137

[Get Quote](#)

N-(3-methoxyphenyl)piperazine, also known as 3-MeOPP, belongs to the arylpiperazine class of compounds. This structural motif is a cornerstone in medicinal chemistry, widely regarded as a "privileged structure" due to its presence in numerous clinically successful drugs. [1][2] The piperazine ring's two nitrogen atoms can be readily modified, allowing for the fine-tuning of a molecule's pharmacological and pharmacokinetic properties, such as water solubility and oral bioavailability.[1] **N-(3-methoxyphenyl)piperazine** serves as a versatile precursor in the synthesis of complex molecules designed to interact with various neurotransmitter systems, particularly as ligands for dopamine (D₂) and serotonin (5-HT_{1a}, 5-HT_{2a}) receptors, making it a critical building block for potential treatments of neurological disorders.[1]

Core Physicochemical Profile

A precise understanding of a compound's physicochemical properties is fundamental to its application in research and development. These parameters govern its behavior in both chemical reactions and biological systems. The properties of **N-(3-methoxyphenyl)piperazine** are summarized below.

Property	Value	Source(s)
CAS Number	16015-71-7	[1][3][4]
Molecular Formula	C ₁₁ H ₁₆ N ₂ O	[3][5]
Molecular Weight	192.26 g/mol	[1][4][5]
Appearance	Colorless to light yellow clear liquid	[1][3]
Boiling Point	150 °C @ 0.5 mmHg; 145 °C @ 0.3 mmHg; 344 °C @ 760 mmHg	[3][4][6]
Melting Point	Not applicable (liquid at STP); Dihydrochloride salt: 214-240 °C	[7][8]
Density	1.114 g/mL at 25 °C	[1][3][4][7]
Refractive Index (n ²⁰ /D)	1.5815	[3][4][7]
pKa (Predicted)	8.98 ± 0.10	[3]
UV Absorbance Max	210 nm (in aqueous acid)	[8]

Note on Physical State: While some databases report a high melting point (201-204 °C), this is inconsistent with its documented state as a liquid at room temperature.[3][6] Such values likely correspond to a salt form, such as the dihydrochloride, which is a crystalline solid.[8] The free base is a liquid under standard conditions.

Structural Elucidation and Spectroscopic Signature

Confirming the identity and purity of **N-(3-methoxyphenyl)piperazine** is a critical first step in any experimental workflow. This is achieved through a combination of spectroscopic techniques, each providing a unique piece of the structural puzzle.

Key Identifiers:

- IUPAC Name: 1-(3-methoxyphenyl)piperazine[9]

- SMILES: COC1=CC=CC(=C1)N2CCNCC2[4][9]
- InChI Key: PZIBVWUXWNYTNL-UHFFFAOYSA-N[4][9]

Expected Spectroscopic Data:

- ^1H NMR: The proton NMR spectrum is expected to show distinct signals for the aromatic protons of the methoxy-substituted ring, a singlet for the methoxy group protons (~3.8 ppm), and characteristic multiplets for the non-equivalent methylene protons on the piperazine ring.
- ^{13}C NMR: The carbon spectrum will display signals for the unique carbons of the substituted benzene ring and two distinct signals for the piperazine ring carbons, confirming the molecule's symmetry.[9]
- Mass Spectrometry (MS): Electron impact (EI) or electrospray ionization (ESI) will show a molecular ion peak $[\text{M}]^+$ at m/z 192. Key fragmentation patterns would include the loss of piperazine fragments, with major peaks often observed around m/z 150 and 135.[9]
- Infrared (IR) Spectroscopy: The IR spectrum will feature characteristic C-H stretching vibrations for both aromatic and aliphatic groups, C-N stretching from the piperazine, and prominent C-O stretching from the methoxy ether group.[9]

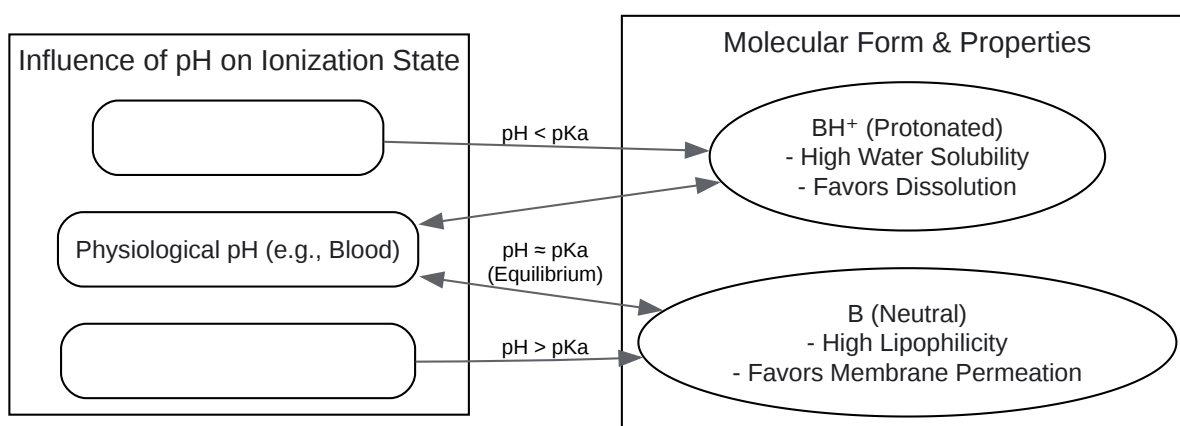

[Click to download full resolution via product page](#)

Caption: Relationship between pH, pKa, and molecular form.

Standardized Experimental Methodologies

To ensure reproducibility and accuracy, the characterization of **N-(3-methoxyphenyl)piperazine** should follow validated analytical protocols.

Chromatographic Analysis for Purity and Quantification (GC-FID)

Gas chromatography with a flame ionization detector (GC-FID) is a robust method for assessing the purity and quantifying the concentration of volatile and semi-volatile compounds. The following protocol is adapted from standard forensic chemistry methodologies. [8]

Objective: To determine the purity of a sample of **N-(3-methoxyphenyl)piperazine**.

Protocol Steps:

- Internal Standard (IS) Preparation: Prepare a stock solution of a suitable internal standard (e.g., dimethylphthalate) at 0.25 mg/mL in methanol. [8]2. Standard Solution Preparation: Accurately weigh ~10 mg of **N-(3-methoxyphenyl)piperazine** reference standard and dissolve in 10.0 mL of the IS stock solution to create a standard of ~1.0 mg/mL. [8]3. Sample Preparation: Prepare the unknown sample in the same manner as the standard solution, ensuring the final concentration is approximately 1.0 mg/mL.
- GC-FID Instrument Conditions:
 - Column: 5% phenyl/95% methyl silicone, 10 m x 0.32 mm x 0.52 μ m film thickness. [8] * Carrier Gas: Hydrogen at 1.0 mL/min. [8] * Temperatures: Injector: 280°C; Detector: 280°C. [8] * Oven Program: Initial 130°C for 1.0 min, ramp to 200°C at 25°C/min, hold for 1.0 min. [8] * Injection: 1 μ L with a split ratio of 50:1. [8]5. Analysis: Inject the standard and sample solutions. The purity of the sample is determined by comparing the peak area ratio of the analyte to the internal standard against that of the reference standard. The expected retention time for **N-(3-methoxyphenyl)piperazine** under these conditions is approximately 3.46 minutes. [8]

Determination of pKa by Potentiometric Titration

This method provides an experimental value for the acid dissociation constant, which is more reliable than predicted values for downstream applications.

Objective: To experimentally determine the pKa of **N-(3-methoxyphenyl)piperazine**.

Protocol Steps:

- **Sample Preparation:** Accurately prepare a solution of the compound (e.g., 0.01 M) in deionized water, often with a co-solvent like methanol if solubility is low.
- **Titration Setup:** Use a calibrated pH meter and an automated titrator. Place the sample solution in a jacketed beaker to maintain a constant temperature (e.g., 25 °C).
- **Titration:** Titrate the solution with a standardized strong acid (e.g., 0.1 M HCl). The titrator should add small, precise volumes of the acid and record the pH after each addition.
- **Data Analysis:** Plot the pH versus the volume of titrant added. The pKa is determined from the titration curve. For a monoprotic base (in the relevant pH range), the pKa is equal to the pH at the half-equivalence point (the point where half of the base has been neutralized). The resulting data can be analyzed using appropriate software to derive the precise pKa value(s).

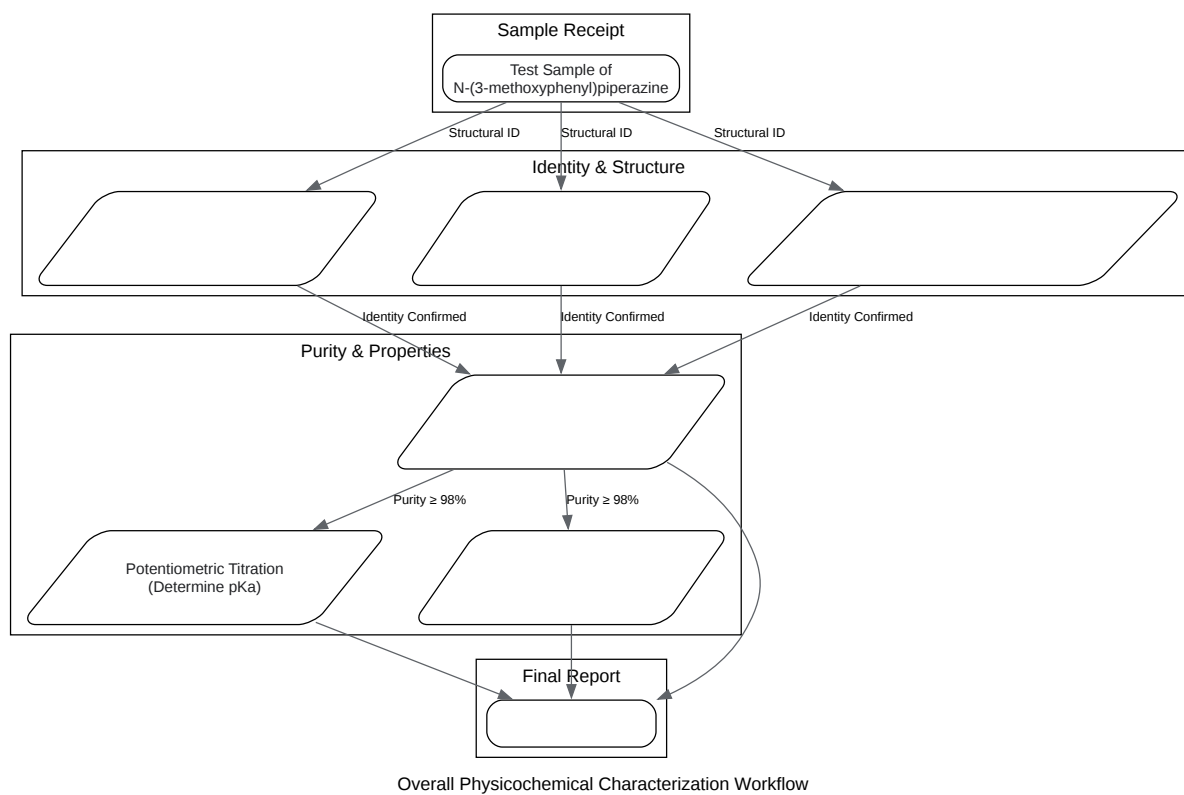

[Click to download full resolution via product page](#)

Caption: A typical workflow for comprehensive physicochemical characterization.

Safety, Handling, and Storage

Proper handling of **N-(3-methoxyphenyl)piperazine** is essential for laboratory safety.

- Hazards: The compound is classified as corrosive and can cause severe skin burns and eye damage. [9]It may also cause respiratory irritation. [10]* Personal Protective Equipment (PPE): Always wear protective gloves, safety glasses or goggles, and a lab coat. Handle in a well-ventilated area or a chemical fume hood. [11][12]* Handling: Avoid breathing vapors or mist. Keep away from sources of ignition as the material is combustible. [11]Take measures to prevent the buildup of electrostatic charge.
- Storage: Store in a cool, dry, and well-ventilated place. It is noted as being air-sensitive, so storage under an inert atmosphere (e.g., argon or nitrogen) is recommended for long-term stability. [3]Keep containers tightly closed. [11]

References

- Chemsrc. (n.d.). 1-(3-Methoxyphenyl)piperazine | CAS#:16015-71-7. Retrieved from [\[Link\]](#)
- ChemSynthesis. (n.d.). 1-(3-methoxyphenyl)piperazine - 16015-71-7. Retrieved from [\[Link\]](#)
- MDPI. (n.d.). Structural Aspects of Arylpiperazines as Aminergic GPCR Ligands. Retrieved from [\[Link\]](#)
- GSRS. (n.d.). **N-(3-METHOXYPHENYL)PIPERAZINE**. Retrieved from [\[Link\]](#)
- SWGDrug. (2005). 1-(3-METHOXYPHENYL)PIPERAZINE. Retrieved from [\[Link\]](#)
- PubChem. (n.d.). **N-(3-methoxyphenyl)piperazine** | C11H16N2O | CID 81430. Retrieved from [\[Link\]](#)
- PubChem. (n.d.). **N-(3-Methoxyphenyl)piperazine** hydrochloride | C11H17ClN2O | CID 12645572. Retrieved from [\[Link\]](#)
- PubMed Central. (n.d.). Synthesis and Determination of Physicochemical Properties of New 3-(4-Arylpiperazin-1-yl)-2-hydroxypropyl 4-Alkoxyethoxybenzoates. Retrieved from [\[Link\]](#)

- ACS Publications. (2001). Synthesis and Structure–Activity Relationships of a New Model of Arylpiperazines. 5. Study of the Physicochemical Influence of the Pharmacophore on 5-HT1A/ α 1-Adrenergic Receptor Affinity. Retrieved from [[Link](#)]
- Semantic Scholar. (2015). Spectroscopic Investigation (FT-IR, FT-Raman, NMR and UV-Vis)...of 1-(2-Methoxyphenyl) Piperazine. Retrieved from [[https://www.semanticscholar.org/paper/Spectroscopic-Investigation-\(FT-IR%2C-FT-Raman%2C-NMR-Subashini-Kumari/2c5a083a2168926b0f15c7e42d79043c7b889381\)](https://www.semanticscholar.org/paper/Spectroscopic-Investigation-(FT-IR%2C-FT-Raman%2C-NMR-Subashini-Kumari/2c5a083a2168926b0f15c7e42d79043c7b889381)] ([[Link](#)])
- ResearchGate. (n.d.). Discovery of Arylpiperazines with Broad-Spectrum Antimicrobial Activity and Favorable Pharmacokinetic Profiles. Retrieved from [[Link](#)]

Need Custom Synthesis?

BenchChem offers custom synthesis for rare earth carbides and specific isotopic labeling.

Email: info@benchchem.com or [Request Quote Online](#).

Sources

1. N-(3-methoxyphenyl)piperazine | 16015-71-7 | Benchchem [[benchchem.com](https://www.benchchem.com)]
2. Structural Aspects of Arylpiperazines as Aminergic GPCR Ligands | MDPI [[mdpi.com](https://www.mdpi.com)]
3. 1-(3-Methoxyphenyl)piperazine CAS#: 16015-71-7 [[m.chemicalbook.com](https://www.m.chemicalbook.com)]
4. 1-(3-甲氧基苯基)哌嗪 95% | Sigma-Aldrich [[sigmaaldrich.com](https://www.sigmaaldrich.com)]
5. GSRS [[gsrs.ncats.nih.gov](https://www.gsrs.ncats.nih.gov)]
6. 1-(3-Methoxyphenyl)piperazine | CAS#:16015-71-7 | Chemsrsc [[chemsrc.com](https://www.chemsrc.com)]
7. chemsynthesis.com [[chemsynthesis.com](https://www.chemsynthesis.com)]
8. swgdrug.org [[swgdrug.org](https://www.swgdrug.org)]
9. N-(3-methoxyphenyl)piperazine | C11H16N2O | CID 81430 - PubChem [pubchem.ncbi.nlm.nih.gov]
10. fishersci.com [[fishersci.com](https://www.fishersci.com)]
11. 1-(3-Methoxyphenyl)piperazine - Safety Data Sheet [[chemicalbook.com](https://www.chemicalbook.com)]
12. static.cymitquimica.com [[static.cymitquimica.com](https://www.static.cymitquimica.com)]

- To cite this document: BenchChem. [Introduction: The Significance of the Arylpiperazine Scaffold]. BenchChem, [2026]. [Online PDF]. Available at: [<https://www.benchchem.com/product/b174137/docs#introduction-the-significance-of-the-arylpiperazine-scaffold>]

Disclaimer & Data Validity:

The information provided in this document is for Research Use Only (RUO) and is strictly not intended for diagnostic or therapeutic procedures. While BenchChem strives to provide accurate protocols, we make no warranties, express or implied, regarding the fitness of this product for every specific experimental setup.

Technical Support: The protocols provided are for reference purposes. Unsure if this reagent suits your experiment?

Need Industrial/Bulk Grade? [Request Custom Synthesis Quote](#)

BenchChem

Our mission is to be the trusted global source of essential and advanced chemicals, empowering scientists and researchers to drive progress in science and industry.

Contact

Address: 3281 E Guasti Rd
Ontario, CA 91761, United States
Phone: (601) 213-4426
Email: info@benchchem.com

[Contact our Ph.D. Support Team for a compatibility check](#)