

Technical Support Center: Stability & Degradation of Acetoxy-Containing Compounds

Author: BenchChem Technical Support Team. **Date:** February 2026

Compound of Interest

Compound Name:	DL-3-(1-ACETOXY-1-METHYLETHYL)-6-OXOHEPTANENITRILE
CAS No.:	131447-89-7
Cat. No.:	B144965

[Get Quote](#)

Core Directive & Scope

Welcome to the Technical Support Center. This guide addresses the stability profiles of acetoxy-containing compounds ($R-O-C(=O)CH_3$). Whether you are developing acetylated prodrugs (e.g., aspirin analogs), working with acetyl-protected carbohydrates, or analyzing polymer degradation, the acetoxy group represents a specific liability: it is a "good enough" leaving group to be labile, yet stable enough to be a common structural motif.

This guide is structured as a Level 3 Technical Escalation, moving beyond basic definitions to causal analysis and remediation.

Diagnostic Module: Hydrolytic Instability

The Issue: The most common degradation pathway for acetoxy compounds is hydrolysis, yielding the parent alcohol and acetic acid. This reaction is ubiquitous in aqueous media and is catalyzed by acids, bases, and buffer species.

Troubleshooting Guide: "My compound is degrading in buffer."

Symptom	Probable Cause	Diagnostic Step	Remediation Protocol
Degradation at pH > 7	Base-Catalyzed Hydrolysis (Specific Base Catalysis)	Measure at pH 7, 8, and 9. If rate increases 10-fold per pH unit, it is specific base catalysis ().	Shift formulation to pH 4.0–5.0 (the typical stability maximum for esters). Store frozen.
Degradation at pH < 3	Acid-Catalyzed Hydrolysis	Check stability in 0.1 N HCl vs. pH 4 buffer.	Avoid strong acidic quenchers in HPLC; use cold acetate buffer instead.
Degradation at pH 4-6 (Stability Window)	General Base Catalysis (Buffer Effect)	Perform a "Buffer Dilution Experiment": Keep pH constant, vary buffer concentration (e.g., 10mM vs 50mM phosphate).	If rate increases with buffer conc., switch to non-nucleophilic buffers (e.g., MES, Acetate) instead of Phosphate or Imidazole.

Mechanistic Insight: The U-Shaped Profile

Most acetoxy compounds follow a pseudo-first-order degradation kinetic profile described by:

- (Acid region): Protonation of the carbonyl oxygen makes the carbon highly electrophilic.
- (Base region): Direct nucleophilic attack by hydroxide. This is typically orders of magnitude faster than acid hydrolysis for simple aliphatic acetates.
- (Water reaction): Spontaneous hydrolysis (usually negligible unless the ester is highly activated).

Visualization: Hydrolysis Pathway

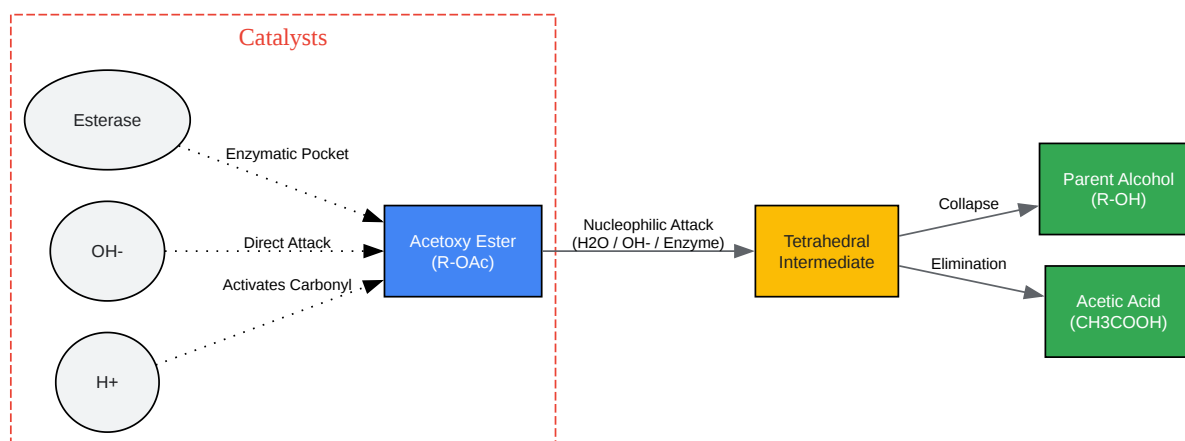

[Click to download full resolution via product page](#)

Figure 1: General hydrolysis mechanism showing the transition from ester to tetrahedral intermediate, catalyzed by acid, base, or enzymes.[1][2]

Diagnostic Module: Biological Stability (Plasma)

The Issue: Acetoxy groups are classic "prodrug handles" designed to be cleaved in vivo. However, if they cleave too fast in ex vivo assays (plasma stability), you cannot accurately measure the parent compound.

Troubleshooting Guide: "My prodrug vanishes in plasma assays."

Q: I see 100% conversion to the parent drug in < 2 minutes in rat plasma. Is my compound chemically unstable? A: Likely not chemically unstable, but enzymatically labile. Rat plasma has significantly higher carboxylesterase activity than human plasma.

Protocol: Stabilizing Plasma Samples To differentiate chemical vs. enzymatic instability, you must inhibit the enzymes immediately upon blood draw.

- Temperature Control: Process all blood/plasma on wet ice ().
- Inhibitor Cocktail (The "Gold Standard"):
 - Sodium Fluoride (NaF): Broad-spectrum esterase inhibitor. Add to collection tubes (2–5 mg/mL).
 - Dichlorvos or PMSF: Use if NaF is insufficient (requires safety handling).
 - Acidification: Lowering plasma pH to 4.0 with dilute phosphoric acid often halts esterase activity and stabilizes the ester chemically.

Self-Validation Step: Run a control incubation in heat-inactivated plasma (heated to for 30 mins).

- If degradation stops: It is enzymatic.
- If degradation persists: It is chemical hydrolysis (see Module 2).

Diagnostic Module: Acyl Migration

The Issue: In compounds with adjacent hydroxyl groups (1,2-diols or 1,3-diols), the acetyl group can "hop" to the neighbor. This is common in glycerol derivatives (mono- and di-glycerides) and carbohydrate chemistry.

Mechanism: The Orthoester Intermediate

Acyl migration is base-catalyzed.^[1] A neighboring hydroxyl deprotonates and attacks the ester carbonyl, forming a cyclic orthoester. This ring opens to place the acetyl group on the adjacent oxygen.

Key Characteristic: This reaction is reversible and leads to an equilibrium mixture of isomers (e.g., 2-acetyl vs. 3-acetyl).

Troubleshooting Guide: "I see split peaks in LC-MS."

Observation	Root Cause	Solution
Doublets in NMR/HPLC	Acyl Migration (Isomerization)	Lower the pH of your mobile phase/solvent. Migration is suppressed at pH < 5.
Shift in retention time	Migration during sample prep	Avoid dissolving samples in protic solvents (MeOH/EtOH) for long periods. Use ACN or DMSO.
Isomers in solid state	Moisture-mediated migration	Store under strict desiccation. Surface moisture on crystals can catalyze migration.

Visualization: Acyl Migration Pathway

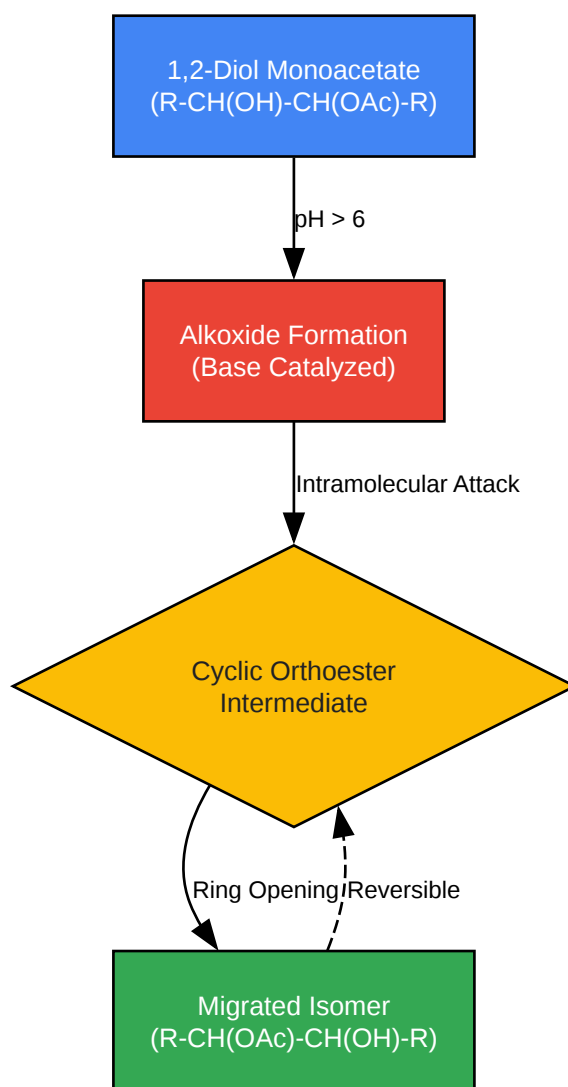

[Click to download full resolution via product page](#)

Figure 2: Acyl migration mechanism via the cyclic orthoester intermediate. Note the reversibility, leading to equilibrium mixtures.[3]

Frequently Asked Questions (FAQs)

Q1: Why does my acetoxy compound smell like vinegar? A: This indicates hydrolysis is occurring in the solid state. Acetic acid has a low odor threshold. This is usually driven by residual moisture in the vial or hygroscopicity of the salt form.

- Action: Dry the sample under high vacuum (

mbar) and store with desiccant capsules. Check if the compound is an HCl salt; HCl can attract moisture and catalyze hydrolysis (autocatalysis).

Q2: Can I use Methanol as a solvent? A: Use with caution. In the presence of base or acid catalysts, transesterification can occur, converting your R-OAc to R-OH + Methyl Acetate. Acetonitrile (ACN) is the preferred aprotic solvent for acetoxy stability.

Q3: What is the "pH of Maximum Stability"? A: For most simple acetoxy esters (like aspirin or aliphatic prodrugs), the pH-rate profile is U-shaped with a minimum (maximum stability) typically between pH 3.5 and 5.0. At this pH, both specific acid and specific base catalysis are minimized.

References

- Bundgaard, H., et al. (1988).[4] "Aspirin prodrugs: synthesis and hydrolysis of 2-acetoxybenzoate esters of various N-(hydroxyalkyl) amides." International Journal of Pharmaceutics. [Link](#)
- Perrie, Y., & Rades, T. (2012). Pharmaceutics: Drug Delivery and Targeting. (Chapter on Prodrug Stability).
- Testa, B., & Mayer, J. M. (2003). Hydrolysis in Drug and Prodrug Metabolism. Wiley-VCH. (Definitive text on esterase activity and chemical hydrolysis).
- Wang, J., et al. (2011). "Acyl migration in drug development: mechanisms, implications, and control strategies." Journal of Pharmaceutical Sciences.
- Muraoka, S., et al. (2006). "Enzymatic hydrolysis of acetoxy prodrugs in rat and human plasma." Biol. Pharm. Bull. (Comparison of species differences in esterase activity).

Need Custom Synthesis?

BenchChem offers custom synthesis for rare earth carbides and specific isotopic labeling.

Email: info@benchchem.com or [Request Quote Online](#).

Sources

- 1. Acyl Group Migration in Pyranosides as Studied by Experimental and Computational Methods - PMC [[pmc.ncbi.nlm.nih.gov](https://pubmed.ncbi.nlm.nih.gov/)]

- [2. Acetal Hydrolysis Mechanism - Chemistry Steps \[chemistrysteps.com\]](#)
- [3. youtube.com \[youtube.com\]](#)
- [4. semanticscholar.org \[semanticscholar.org\]](#)
- To cite this document: BenchChem. [Technical Support Center: Stability & Degradation of Acetoxy-Containing Compounds]. BenchChem, [2026]. [Online PDF]. Available at: [<https://www.benchchem.com/product/b144965#degradation-pathways-for-acetoxy-containing-compounds>]

Disclaimer & Data Validity:

The information provided in this document is for Research Use Only (RUO) and is strictly not intended for diagnostic or therapeutic procedures. While BenchChem strives to provide accurate protocols, we make no warranties, express or implied, regarding the fitness of this product for every specific experimental setup.

Technical Support: The protocols provided are for reference purposes. Unsure if this reagent suits your experiment? [[Contact our Ph.D. Support Team for a compatibility check](#)]

Need Industrial/Bulk Grade? [Request Custom Synthesis Quote](#)

BenchChem

Our mission is to be the trusted global source of essential and advanced chemicals, empowering scientists and researchers to drive progress in science and industry.

Contact

Address: 3281 E Guasti Rd

Ontario, CA 91761, United States

Phone: (601) 213-4426

Email: info@benchchem.com