

Storage and stabilization protocols for volatile fluorinated dienes

Author: BenchChem Technical Support Team. **Date:** May 2026

Compound of Interest

Compound Name: 2-Chloro-1,1,1,6,6,6-hexafluorohexa-2,4-diene
CAS No.: 885276-10-8
Cat. No.: B1439254

[Get Quote](#)

Application Note: Storage and Stabilization Protocols for Volatile Fluorinated Dienes

Executive Summary

Volatile fluorinated dienes (e.g., Hexafluoro-1,3-butadiene, HFBD) are critical synthons in pharmaceutical cycloadditions and semiconductor etching. However, their electron-deficient nature renders them uniquely susceptible to two distinct degradation pathways: radical-mediated polymerization and thermally driven [2+2] cycloaddition (dimerization). This guide provides a rigorous, self-validating framework for the long-term preservation of these high-value intermediates, moving beyond standard Safety Data Sheet (SDS) recommendations to address the practical realities of the laboratory environment.

Part 1: The Stability Challenge (Mechanistic Insight)

To stabilize fluorinated dienes, one must first understand the "Enemy." Unlike non-fluorinated analogs (e.g., butadiene), the presence of electronegative fluorine atoms alters the highest occupied molecular orbital (HOMO) energy, affecting reactivity.

- Radical Polymerization (The "Popcorn" Risk):
 - Mechanism: Trace oxygen forms peroxides, which decompose to initiate chain growth. In fluorodienes, this often results in insoluble, cross-linked "popcorn" polymers that can foul valves and rupture glass vessels due to volume expansion.
 - Mitigation: Radical scavengers (inhibitors) and strict anaerobic conditions.
- [2+2] Cycloaddition (The Silent Killer):
 - Mechanism: Even in the absence of radicals, fluorinated dienes can spontaneously dimerize via a thermal [2+2] mechanism to form cyclobutane derivatives. This is a second-order reaction dependent on concentration and temperature.
 - Mitigation: Cryogenic storage. Inhibitors do NOT stop this process.

Visualizing Degradation Pathways

The following diagram illustrates the divergent degradation logic and the intervention points for stabilization.

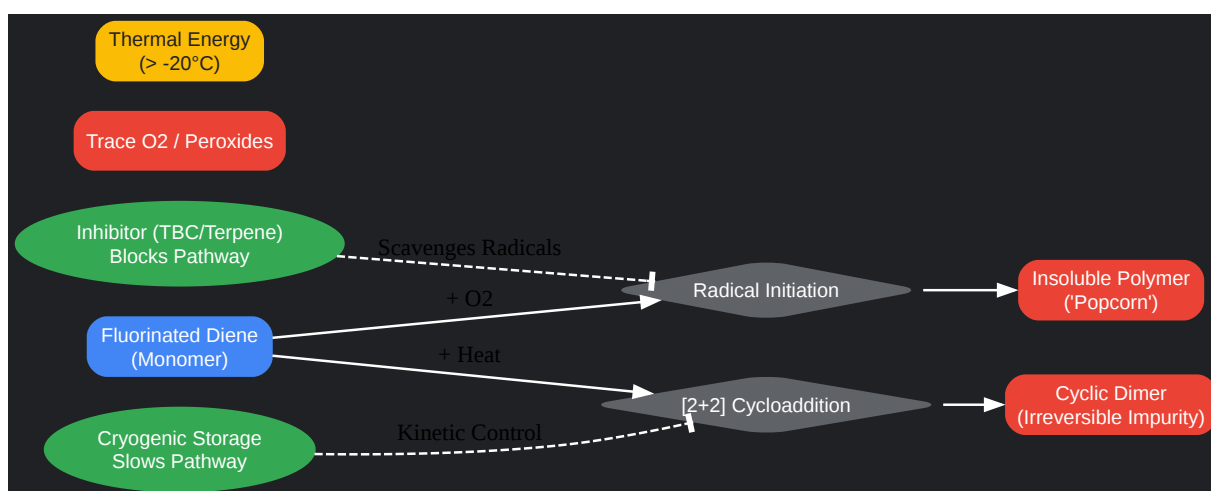

[Click to download full resolution via product page](#)

Figure 1: Dual degradation pathways for fluorinated dienes. Note that chemical inhibitors only prevent polymerization, not dimerization.

Part 2: Material Compatibility & Vessel Selection

Fluorinated compounds can hydrolyze to generate Hydrogen Fluoride (HF), particularly at metal surfaces. HF is highly corrosive and can catalyze further decomposition.[1]

Critical Rule: Avoid Aluminum. Aluminum salts can act as Lewis Acid catalysts, stripping fluorine and initiating rapid, exothermic decomposition (the "etch" effect).

Table 1: Material Compatibility Matrix

Material	Compatibility	Notes
Stainless Steel (316L)	Excellent	The gold standard. Passivates well. Mandatory for high-pressure storage.
Monel / Inconel	Superior	Best for long-term storage if trace HF is suspected. Expensive.
Aluminum / Brass	DANGEROUS	DO NOT USE. Risk of Lewis acid catalysis () and catastrophic failure.
Borosilicate Glass	Good	Acceptable for short-term, low-pressure (<1.5 bar) observation. Inspect for etching.
PTFE / Kalrez	Excellent	Preferred gasket/seal material. Avoid Viton if amines are present.

Part 3: Stabilization Protocols

Protocol A: Inhibitor Dosing & Verification

Objective: Introduce a radical scavenger to prevent polymerization during storage at

to

Recommended Inhibitors:

- 4-tert-Butylcatechol (TBC): Standard. Effective at 100–200 ppm. Requires removal before catalysis.
- d-Limonene: A "green" alternative. Acts as a sacrificial radical trap. Useful if TBC interferes with downstream analytics.

Step-by-Step Dosing:

- Calculate Load: For 100 g of diene, target 150 ppm TBC.
- Preparation: Dissolve TBC in a minimum volume of dry

or inject as a concentrated solution if the diene is liquid. If the diene is gaseous, coat the interior of the cylinder with the inhibitor solution and evaporate the solvent before filling.
- Self-Validation (The "Color Test"):
 - TBC turns faint pink/brown when oxidized (active).
 - Check: If the liquid phase is crystal clear, you may have insufficient inhibitor or total oxygen exclusion (good). If it is dark brown/black, the inhibitor is exhausted, and the batch must be redistilled immediately.

Protocol B: Cryogenic Vacuum Transfer (The "Transfer Line")

Objective: Transfer volatile dienes without exposure to air (oxygen/moisture). This is the only acceptable method for handling high-purity fluorodienes.

Equipment:

- Vacuum manifold (Schlenk line) ().
- Liquid Nitrogen () Dewar.
- Stainless steel or heavy-wall glass cold trap.

Workflow Diagram:

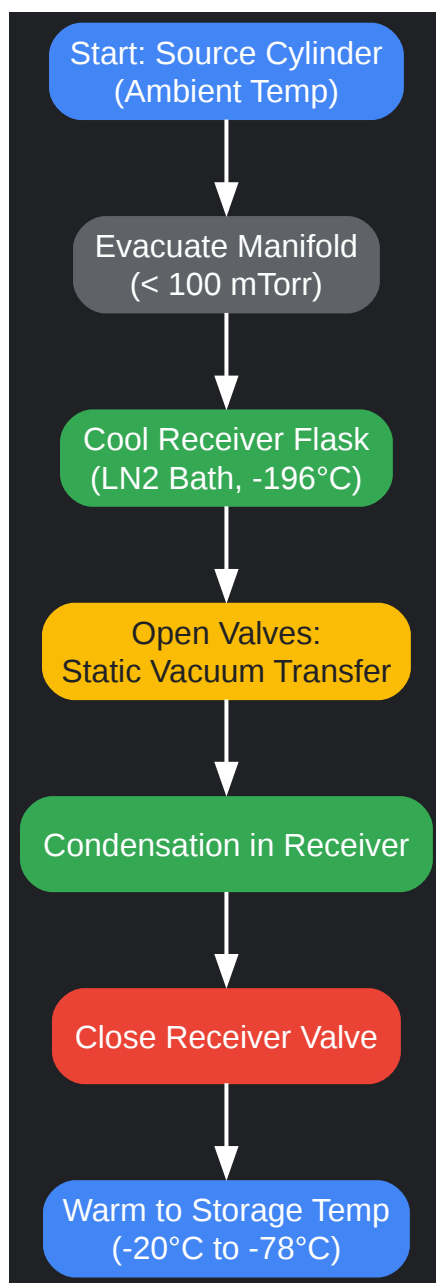

[Click to download full resolution via product page](#)

Figure 2: Cryogenic vacuum transfer workflow for volatile fluorinated dienes.

Detailed Steps:

- Passivation: Ensure the receiving vessel (SS cylinder or heavy-wall ampoule) is baked out under vacuum to remove adsorbed water.
- Connection: Attach Source (A) and Receiver (B) to the manifold. Evacuate lines to

- Cryo-Pumping: Submerge Receiver (B) in liquid nitrogen ().
- Transfer: Close the vacuum source. Slowly open Source (A). The vapor pressure differential will drive the diene into Receiver (B), where it solidifies.
 - Note: Monitor the manometer. If pressure rises significantly, you have a non-condensable gas leak (/).
- Termination: Close both valves. Allow Receiver (B) to warm to room temperature behind a blast shield if using glass, or place immediately in a freezer.

Part 4: Quality Control & Emergency Response

1. Routine Monitoring (Self-Validating System):

- Visual Inspection: Check for "cloudiness" or solid precipitates (dimer/polymer) monthly.
- NMR Validation: Run a NMR.
 - Monomer: Sharp, distinct olefinic peaks.
 - Dimer: New signals, typically upfield (shielded) due to loss of conjugation.
 - HF:[1][2][3] Broad peak around -150 to -200 ppm (solvent dependent).

2. Emergency Venting: If a storage vessel shows signs of rapid pressure buildup (polymerization exotherm):

- Do NOT open manually.
- Connect to a remote venting system or "dump tank" containing 10% aqueous NaOH (to neutralize HF and scrub the diene).

References

- National Institute of Standards and Technology (NIST). (2023). Hexafluoro-1,3-butadiene: Thermochemical Data. NIST Chemistry WebBook. [[Link](#)]
- Airgas. (2022). Safety Data Sheet: Hexafluoro-1,3-butadiene. [[Link](#)]
- NASA. (1995). Selection of Compatible Materials for Use with Fluorine and Fluorine Compounds. NASA Technical Reports Server. [[Link](#)]

Need Custom Synthesis?

BenchChem offers custom synthesis for rare earth carbides and specific isotopic labeling.

Email: info@benchchem.com or [Request Quote Online](#).

Sources

- 1. pdf.benchchem.com [pdf.benchchem.com]
- 2. chemicalbook.com [chemicalbook.com]
- 3. fluoropolymers.eu [fluoropolymers.eu]
- To cite this document: BenchChem. [Storage and stabilization protocols for volatile fluorinated dienes]. BenchChem, [2026]. [Online PDF]. Available at: [<https://www.benchchem.com/product/b1439254/docs#storage-and-stabilization-protocols-for-volatile-fluorinated-dienes>]

Disclaimer & Data Validity:

The information provided in this document is for Research Use Only (RUO) and is strictly not intended for diagnostic or therapeutic procedures. While BenchChem strives to provide

accurate protocols, we make no warranties, express or implied, regarding the fitness of this product for every specific experimental setup.

Technical Support: The protocols provided are for reference purposes. Unsure if this reagent suits your experiment?

Need Industrial/Bulk Grade? [Request Custom Synthesis Quote](#)

BenchChem

Our mission is to be the trusted global source of essential and advanced chemicals, empowering scientists and researchers to drive progress in science and industry.

Contact

Address: 3281 E Guasti Rd

Ontario, CA 91761, United States

Phone: (601) 213-4426

Email: info@benchchem.com

[Contact our Ph.D. Support Team for a compatibility check](#)