

A Comparative Guide to the Metabolic Stability of Fluorinated Cyclopropylamines

Author: BenchChem Technical Support Team. **Date:** May 2026

Compound of Interest

Compound Name: 1-(2-Fluorophenyl)cyclopropan-1-amine hydrochloride

CAS No.: 1215107-57-5

Cat. No.: B1439849

[Get Quote](#)

This guide provides an in-depth comparison of the metabolic stability of fluorinated cyclopropylamines, offering experimental data and mechanistic insights for researchers, scientists, and drug development professionals. By understanding the principles outlined herein, teams can make more informed decisions in the design of robust drug candidates.

Introduction: The Strategic Value of Fluorinated Cyclopropylamines

The cyclopropylamine moiety is a privileged structural motif in medicinal chemistry, valued for the conformational constraint it imparts on aliphatic systems.^[1] However, the amine group often presents a metabolic liability, being susceptible to oxidation by cytochrome P450 (CYP) enzymes.^{[1][2][3]} A primary metabolic fate involves a single-electron transfer (SET) from the nitrogen atom to the CYP heme iron, which can lead to ring-opening and inactivation of the parent molecule.^{[2][3][4]}

Fluorination is a well-established strategy in drug design to enhance metabolic stability.^{[5][6][7]} ^[8] By replacing a metabolically vulnerable C-H bond with a much stronger C-F bond, chemists

can effectively "shield" the molecule from enzymatic attack.^{[9][10]} This guide explores the mechanistic basis for this enhanced stability and provides comparative data to illustrate the profound impact of strategic fluorination.

The Metabolic Challenge: CYP450-Mediated Inactivation of Cyclopropylamines

The primary enzymes responsible for the metabolism of most xenobiotics, including cyclopropylamines, are the cytochrome P450s located predominantly in the liver.^{[11][12]} For cyclopropylamines, a key pathway leading to metabolic clearance and potential bioactivation is initiated by an SET event at the nitrogen atom. This generates a radical cation intermediate that is prone to rapid fragmentation of the strained cyclopropyl ring, leading to covalent modification of the enzyme or formation of reactive metabolites.^{[2][3][4]}

Another pathway involves the formation of metabolic intermediate complexes (MICs), where a nitroso metabolite coordinates tightly to the heme iron of the CYP enzyme, effectively inhibiting its function and preventing further turnover.^{[2][3]}

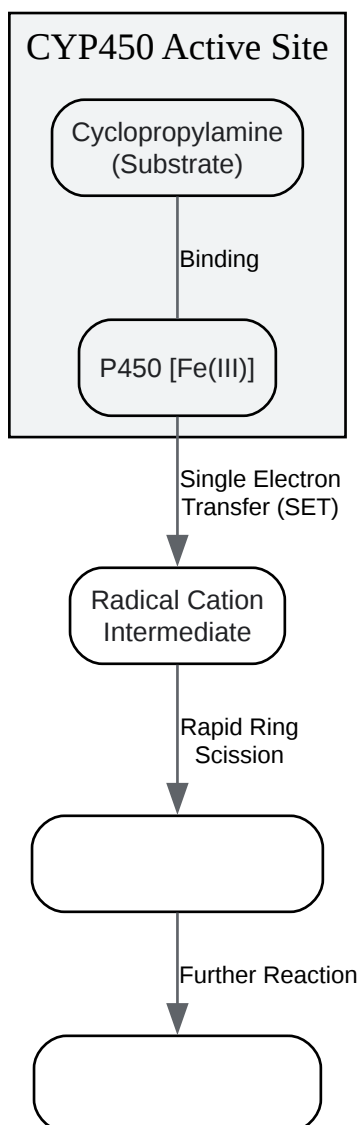

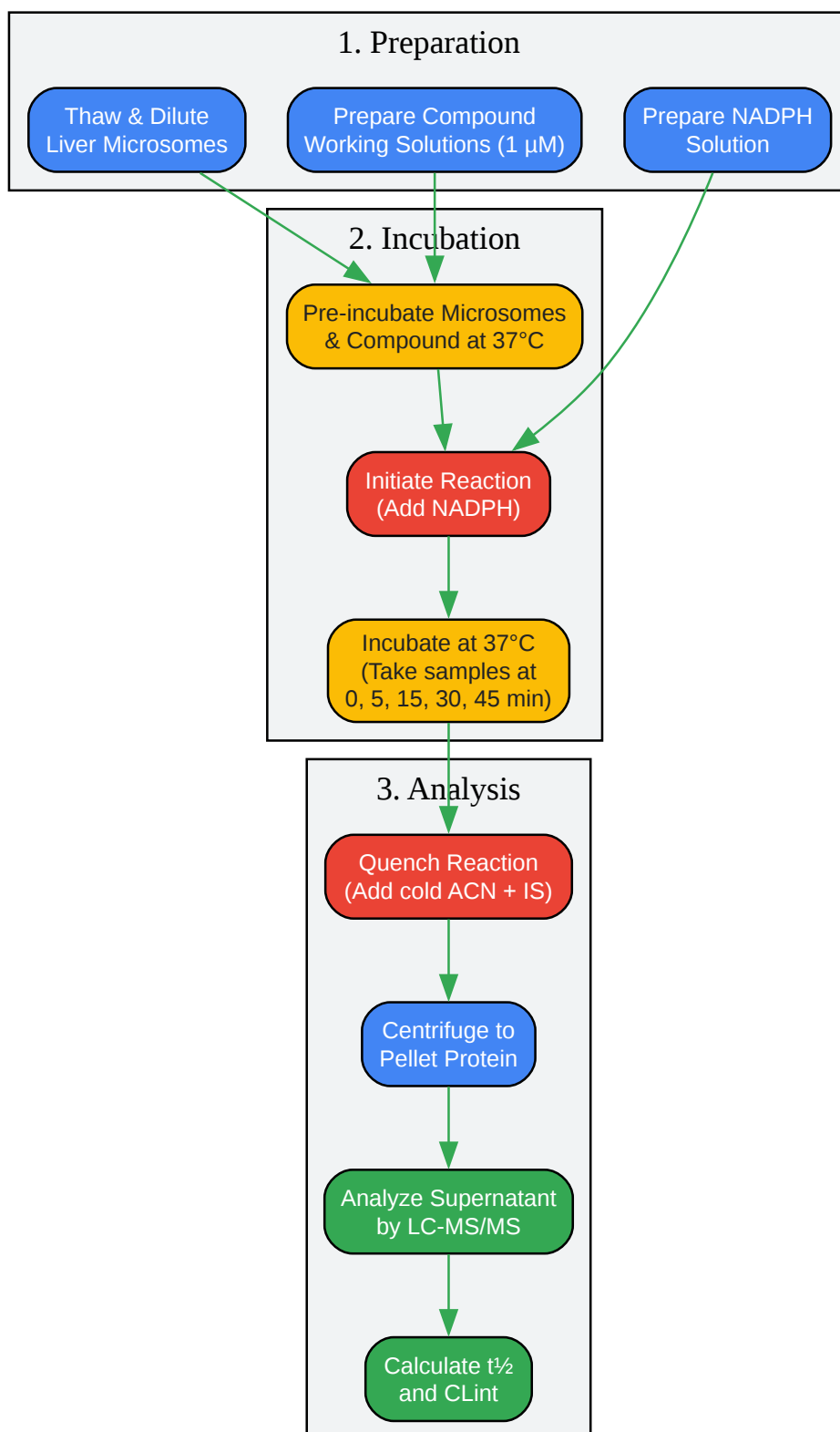

[Click to download full resolution via product page](#)

Caption: Workflow for the in vitro liver microsomal stability assay.

5.4 Step-by-Step Procedure

- Thaw Microsomes: Thaw pooled HLM on ice. Dilute to a final protein concentration of 0.5 mg/mL in 0.1 M phosphate buffer.
- Prepare Incubation Plate: Add the diluted microsome solution and the test compound (final concentration 1 μ M) to the wells of a 96-well plate.
- System Validation (Controls):
 - -NADPH Control: For each compound, include a well without NADPH to measure non-enzymatic degradation. The reaction is quenched at the final time point.
 - Positive Control: Include a known rapidly metabolized compound (e.g., Midazolam) to confirm the metabolic competency of the microsome batch.
 - T=0 Control: A sample quenched immediately after adding the compound, before adding NADPH, represents 100% compound at the start. [13]4. Pre-incubation: Pre-incubate the plate at 37°C for 5-10 minutes with gentle shaking.
- Initiate Reaction: Start the metabolic reaction by adding the pre-warmed NADPH solution.
- Sampling & Quenching: At specified time points (e.g., 0, 5, 15, 30, 45 min), terminate the reaction by adding 2-3 volumes of ice-cold acetonitrile containing a suitable internal standard. [14][15]7. Sample Processing: Centrifuge the plate to pellet the precipitated protein. Transfer the supernatant to a new plate for analysis.
- Analysis: Analyze the samples by LC-MS/MS to determine the ratio of the peak area of the test compound to the internal standard.

5.5 Data Analysis

- Plot the natural logarithm (ln) of the percent remaining of the test compound against time.
- The slope of the linear regression line (k) represents the elimination rate constant.
- Calculate the half-life ($t_{1/2}$) using the formula: $t_{1/2} = 0.693 / k$.

- Calculate the intrinsic clearance (CL_{int}) using the formula: CL_{int} (μL/min/mg protein) = (0.693 / t_{1/2}) * (1 / protein concentration).

Conclusion

Strategic fluorination is a powerful and proven tactic for enhancing the metabolic stability of molecules containing the cyclopropylamine motif. By understanding the underlying mechanisms of CYP450-mediated metabolism, medicinal chemists can rationally design compounds that are less susceptible to metabolic clearance. Introducing fluorine, particularly in a gem-difluoro pattern on the cyclopropyl ring, effectively shields the molecule by increasing the C-F bond strength and raising the oxidation potential of the amine nitrogen. The robust in vitro microsomal stability assay provides a reliable method to quantify these improvements, enabling data-driven optimization of drug candidates for superior pharmacokinetic profiles.

References

- Bhattarai, P., Trombley, T. A., & Altman, R. A. (2026). Metabolic Stability of Fluorinated Small Molecules: A Physical Organic Chemistry Perspective. *Journal of Medicinal Chemistry*. [[Link](#)]
- Shanu-Wilson, J. (n.d.). Metabolism of cyclopropyl groups. *Hypha Discovery Blogs*. [[Link](#)]
- ResearchGate. (n.d.). Structure-Activity Relationship of Fluorinated Benzenesulfonamides as Inhibitors of Amyloid-β Aggregation. Request PDF. [[Link](#)]
- Patel, S. (n.d.). Metabolic Stability and its Role in Biopharmaceutical Development: Trends and Innovations. *Journal of Pharmaceutical Sciences*. [[Link](#)]
- Bhattarai, P., Trombley, T. A., & Altman, R. A. (2025). On the Metabolic Stability of Fluorinated Small Molecules; A Physical Organic Chemistry Perspective. *ChemRxiv*. [[Link](#)]
- *Journal of Drug and Alcohol Research*. (2021). Drug Metabolic Stability in Early Drug Discovery to Develop Potential Lead Compounds. [[Link](#)]
- *Molecules*. (n.d.). The Role of Small Molecules Containing Fluorine Atoms in Medicine and Imaging Applications. *PMC*. [[Link](#)]
- MTTlab. (n.d.). In vitro drug metabolism: for the selection of your lead compounds. [[Link](#)]

- Park, B. K., Kitteringham, N. R., & O'Neill, P. M. (2001). Metabolism of fluorine-containing drugs. *Annual Review of Pharmacology and Toxicology*, 41, 443-470. [[Link](#)]
- *Frontiers in Chemistry*. (2017). Suicide Inhibition of Cytochrome P450 Enzymes by Cyclopropylamines via a Ring-Opening Mechanism: Proton-Coupled Electron Transfer Makes a Difference. [[Link](#)]
- ResearchGate. (n.d.). Improvements to metabolic stability through cyclopropyl modification. [[Link](#)]
- ChemRxiv. (n.d.). On the Metabolic Stability of Fluorinated Small Molecules; A Physical Organic Chemistry Perspective. [[Link](#)]
- ResearchGate. (n.d.). Role of Fluorine in Drug Design and Drug Action. Request PDF. [[Link](#)]
- *Beilstein Journal of Organic Chemistry*. (2025). Thermodynamics and polarity-driven properties of fluorinated cyclopropanes. [[Link](#)]
- Cyprotex. (n.d.). Microsomal Stability. Evotec. [[Link](#)]
- ACS Publications. (n.d.). Mechanism of cytochrome P-450 inhibition by cyclopropylamines. [[Link](#)]
- PubMed. (n.d.). Structure-Activity Relationships for a Series of (Bis(4-fluorophenyl)methyl)sulfinyl Alkyl Alicyclic Amines at the Dopamine Transporter: Functionalizing the Terminal Nitrogen Affects Affinity, Selectivity, and Metabolic Stability. [[Link](#)]
- PubMed. (n.d.). Cyclopropylamine inactivation of cytochromes P450: role of metabolic intermediate complexes. [[Link](#)]
- Taylor & Francis Online. (n.d.). The role of fluorine in medicinal chemistry. [[Link](#)]
- ResearchGate. (n.d.). Protocol for the Human Liver Microsome Stability Assay. [[Link](#)]
- PubMed. (2009). Safety and tolerability of pardoprunox, a new partial dopamine agonist, in a randomized, controlled study of patients with advanced Parkinson's disease. [[Link](#)]

- Merzell. (n.d.). metabolic stability in liver microsomes. [[Link](#)]
- ResearchGate. (n.d.). Cyclopropylamine inactivation of cytochromes P450: Role of metabolic intermediate complexes. [[Link](#)]

Need Custom Synthesis?

BenchChem offers custom synthesis for rare earth carbides and specific isotopic labeling.

Email: info@benchchem.com or [Request Quote Online](#).

Sources

- 1. hyphadiscovery.com [hyphadiscovery.com]
- 2. researchgate.net [researchgate.net]
- 3. Cyclopropylamine inactivation of cytochromes P450: role of metabolic intermediate complexes - PubMed [pubmed.ncbi.nlm.nih.gov]
- 4. Frontiers | Suicide Inhibition of Cytochrome P450 Enzymes by Cyclopropylamines via a Ring-Opening Mechanism: Proton-Coupled Electron Transfer Makes a Difference [frontiersin.org]
- 5. Metabolic Stability of Fluorinated Small Molecules: A Physical Organic Chemistry Perspective - PubMed [pubmed.ncbi.nlm.nih.gov]
- 6. chemrxiv.org [chemrxiv.org]
- 7. researchgate.net [researchgate.net]
- 8. researchgate.net [researchgate.net]
- 9. annualreviews.org [annualreviews.org]
- 10. Fluorine in Pharmaceuticals: Key Properties & Drug Development - AiFChem [aifchem.com]
- 11. longdom.org [longdom.org]
- 12. mttlab.eu [mttlab.eu]
- 13. Thawing and Incubating Human and Animal Liver Microsomes | Thermo Fisher Scientific - TW [thermofisher.com]
- 14. Microsomal Stability | Cyprotex ADME-Tox Solutions | Evotec [evotec.com]

- [15. mercell.com \[mercell.com\]](#)
- To cite this document: BenchChem. [A Comparative Guide to the Metabolic Stability of Fluorinated Cyclopropylamines]. BenchChem, [2026]. [Online PDF]. Available at: [<https://www.benchchem.com/product/b1439849/docs#a-comparative-guide-to-the-metabolic-stability-of-fluorinated-cyclopropylamines>]

Disclaimer & Data Validity:

The information provided in this document is for Research Use Only (RUO) and is strictly not intended for diagnostic or therapeutic procedures. While BenchChem strives to provide accurate protocols, we make no warranties, express or implied, regarding the fitness of this product for every specific experimental setup.

Technical Support: The protocols provided are for reference purposes. Unsure if this reagent suits your experiment?

Need Industrial/Bulk Grade? [Request Custom Synthesis Quote](#)

BenchChem

Our mission is to be the trusted global source of essential and advanced chemicals, empowering scientists and researchers to drive progress in science and industry.

Contact

Address: 3281 E Guasti Rd
Ontario, CA 91761, United States
Phone: (601) 213-4426
Email: info@benchchem.com

[Contact our Ph.D. Support Team for a compatibility check](#)