

# Technical Support Center: Synthesis of 5-Fluoro-2-morpholinobenzoic Acid

**Author:** BenchChem Technical Support Team. **Date:** May 2026

## Compound of Interest

Compound Name:	5-Fluoro-2-morpholinobenzoic acid
CAS No.:	1096880-75-9
Cat. No.:	B1438663

[Get Quote](#)

The synthesis of **5-Fluoro-2-morpholinobenzoic acid**, a valuable building block in medicinal chemistry, typically proceeds via a nucleophilic aromatic substitution (S<sub>N</sub>Ar) reaction. The most common route involves the reaction of 2,5-difluorobenzoic acid with morpholine. The fluorine atom at the 2-position is activated towards substitution by the adjacent carboxylic acid group, making it the primary site of reaction.

However, as with many organic syntheses, the formation of byproducts can complicate the reaction and purification process. This guide will address the most common challenges and provide troubleshooting strategies.

## Frequently Asked Questions (FAQs) & Troubleshooting

**Q1: My reaction is sluggish or incomplete. What are the potential causes and how can I improve the conversion?**

A1: Incomplete conversion is a common issue in S<sub>N</sub>Ar reactions. Several factors can contribute to this:

- **Insufficient reaction temperature:** S<sub>N</sub>Ar reactions often require elevated temperatures to proceed at a reasonable rate. If you are running the reaction at room temperature, consider gently heating it. A temperature range of 80-120 °C is a good starting point, depending on the solvent.
- **Inappropriate solvent:** The choice of solvent is critical. Polar aprotic solvents such as DMSO, DMF, or NMP are generally preferred as they can solvate the cationic species and accelerate the reaction.
- **Base strength:** A base is typically required to deprotonate the morpholine and to neutralize the HF that is formed during the reaction. Common bases include K<sub>2</sub>CO<sub>3</sub>, Cs<sub>2</sub>CO<sub>3</sub>, or an excess of morpholine itself. If the reaction is slow, consider using a stronger base or ensuring that the base is sufficiently dry.
- **Water content:** The presence of water can hinder the reaction by competing with the nucleophile and reacting with the base. Ensure all reagents and solvents are anhydrous.

## Q2: I've isolated my product, but NMR and LC-MS analysis show the presence of an isomer. What is this byproduct and how can I avoid it?

A2: The most likely isomeric byproduct is 2-Fluoro-5-morpholinobenzoic acid. This arises from the substitution of the fluorine atom at the 5-position instead of the 2-position.

While the fluorine at the 2-position is more activated, substitution at the 5-position can still occur, particularly at higher temperatures or with prolonged reaction times.

Mitigation Strategies:

- **Temperature control:** Carefully control the reaction temperature. Running the reaction at the lowest temperature that provides a reasonable rate can improve selectivity.

- Reaction time: Monitor the reaction progress by TLC or LC-MS and stop the reaction once the starting material is consumed to avoid the formation of the thermodynamic product.
- Choice of starting material: While less common, using 2-chloro-5-fluorobenzoic acid could potentially offer different selectivity, though the chloro group is generally less reactive than the fluoro group in SNAr.

## Visualizing the Reaction and Byproduct Formation

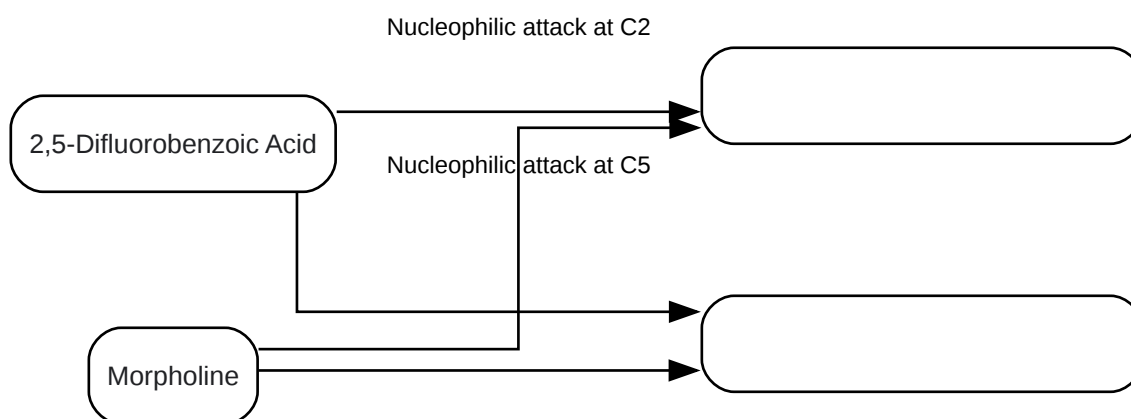

[Click to download full resolution via product page](#)

Caption: Primary reaction pathway and isomeric byproduct formation.

### Q3: My mass spectrometry data shows a peak corresponding to the loss of fluorine and the addition of a hydroxyl group. What is this species?

A3: This byproduct is likely 5-Fluoro-2-hydroxybenzoic acid or 2-Hydroxy-5-fluorobenzoic acid. This can form if there is residual water in your reaction mixture, which can act as a competing nucleophile.

Troubleshooting:

- Anhydrous conditions: Ensure all glassware is oven-dried and the reaction is performed under an inert atmosphere (e.g., nitrogen or argon). Use anhydrous solvents and reagents.

- Purification: This acidic byproduct can often be separated from the desired product by careful pH adjustment during workup or by column chromatography.

## Q4: I am having difficulty purifying my product. What are some recommended purification strategies?

A4: The purification of **5-Fluoro-2-morpholinobenzoic acid** can be challenging due to the presence of structurally similar byproducts. A multi-step approach is often necessary.

Recommended Purification Workflow:

- Aqueous Workup: After the reaction is complete, cool the mixture and quench with water. Acidify the solution with an acid like HCl to a pH of around 3-4. The desired product and any acidic byproducts should precipitate. Filter the solid and wash with cold water.
- Recrystallization: Recrystallization can be an effective method for removing less polar impurities. Solvents to consider include ethanol, isopropanol, or a mixture of ethyl acetate and hexanes.
- Column Chromatography: If recrystallization is insufficient, column chromatography is the next step. A silica gel column with a mobile phase gradient of ethyl acetate in hexanes, often with a small amount of acetic acid (0.5-1%) to keep the carboxylic acid protonated and improve peak shape, is a good starting point.

## Experimental Protocols

### Protocol 1: General Synthesis of 5-Fluoro-2-morpholinobenzoic Acid

- To a solution of 2,5-difluorobenzoic acid (1.0 eq) in a polar aprotic solvent (e.g., DMSO, 5-10 mL per gram of starting material), add morpholine (2.5 eq) and a base such as  $K_2CO_3$  (2.0 eq).
- Heat the reaction mixture to 80-100 °C and monitor its progress by TLC or LC-MS.
- Upon completion, cool the reaction to room temperature and pour it into ice-water.

- Acidify the aqueous solution to pH 3-4 with 1M HCl.
- Collect the resulting precipitate by vacuum filtration and wash with cold water.
- Dry the crude product under vacuum.
- Purify by recrystallization or column chromatography as needed.

## Protocol 2: Analytical Identification of Byproducts by LC-MS

- Column: A C18 reverse-phase column is suitable.
- Mobile Phase: A gradient of acetonitrile in water with 0.1% formic acid is a good starting point.
- Detection: UV detection at 254 nm and mass spectrometry in both positive and negative ion modes.

Compound	Expected [M+H] <sup>+</sup>	Expected [M-H] <sup>-</sup>
5-Fluoro-2-morpholinobenzoic acid	226.09	224.07
2-Fluoro-5-morpholinobenzoic acid	226.09	224.07
2,5-Difluorobenzoic acid (unreacted)	159.02	157.00
5-Fluoro-2-hydroxybenzoic acid	157.03	155.01

## Troubleshooting Workflow

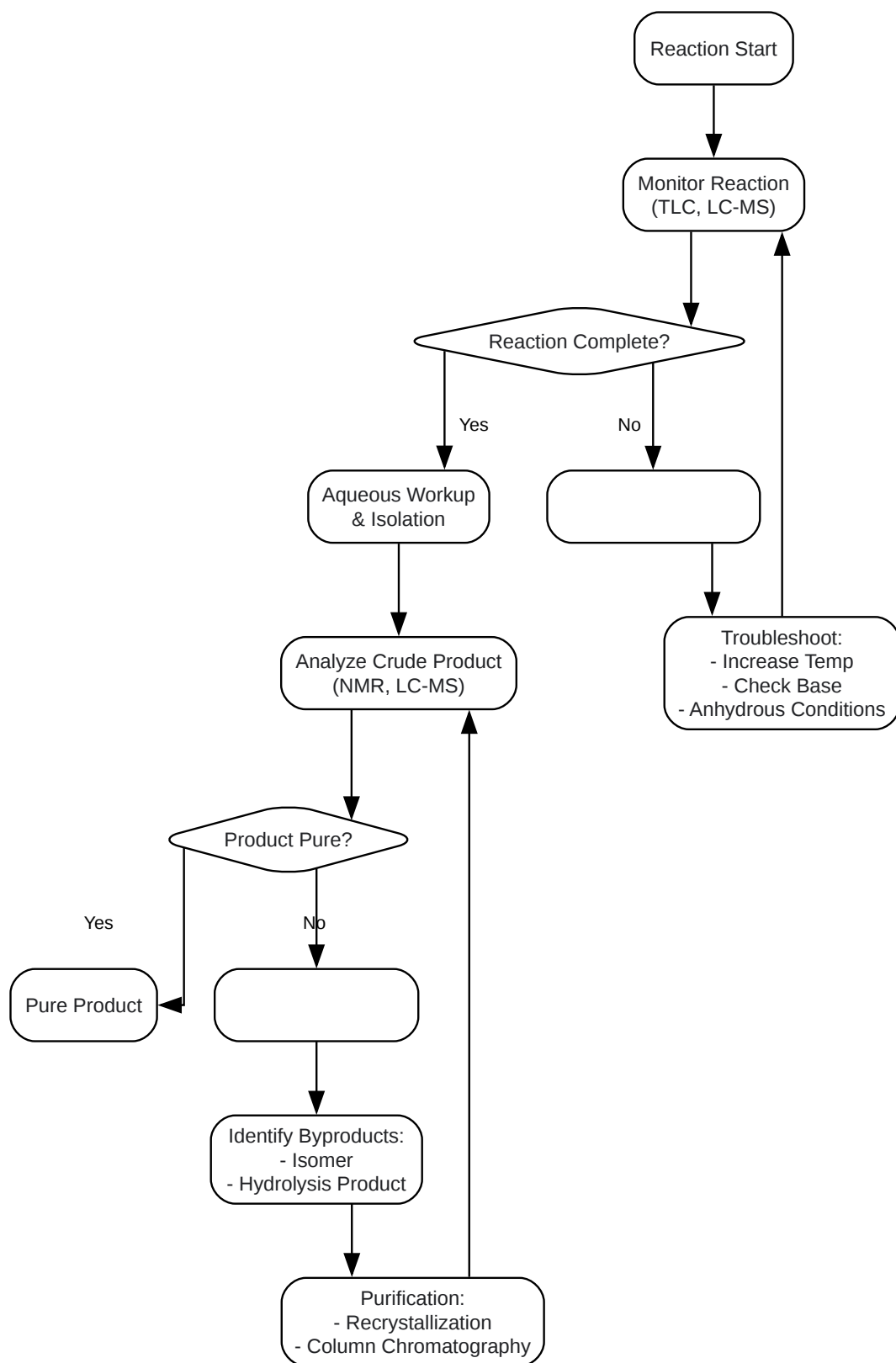

[Click to download full resolution via product page](#)

Caption: A general troubleshooting workflow for the synthesis.

## References

- Nucleophilic Aromatic Substitution: For a general understanding of the S<sub>N</sub>Ar mechanism, resources from educational institutions and chemical suppliers are valuable. While not a peer-reviewed paper, general organic chemistry resources provide the foundational principles.[\[1\]](#)[\[2\]](#)
- Related Syntheses of Fluoro-aromatic Compounds: Patent literature often provides detailed experimental procedures for related molecules, which can be adapted. For instance, the synthesis of other substituted fluorobenzoic acids can offer insights into reaction conditions.[\[3\]](#)[\[4\]](#)[\[5\]](#)
- Buchwald-Hartwig Amination: While the primary focus is on S<sub>N</sub>Ar, for less activated systems, palladium-catalyzed cross-coupling reactions like the Buchwald-Hartwig amination are an alternative. Understanding these methods can be useful for developing alternative synthetic routes.[\[6\]](#)[\[7\]](#)[\[8\]](#)[\[9\]](#)[\[10\]](#)
- Ullmann Condensation: Another classical method for forming aryl-nitrogen bonds is the Ullmann condensation, which could be considered as an alternative synthetic strategy.[\[11\]](#)
- Purification Techniques: Standard organic chemistry laboratory manuals provide comprehensive guidance on purification techniques such as recrystallization and chromatography.[\[12\]](#)
- Solvent Effects in S<sub>N</sub>Ar: The choice of solvent can significantly impact the regioselectivity and rate of S<sub>N</sub>Ar reactions.[\[13\]](#)

### Need Custom Synthesis?

BenchChem offers custom synthesis for rare earth carbides and specific isotopic labeling.

Email: [info@benchchem.com](mailto:info@benchchem.com) or [Request Quote Online](#).

## Sources

- [1. masterorganicchemistry.com](http://masterorganicchemistry.com) [[masterorganicchemistry.com](http://masterorganicchemistry.com)]
- [2. m.youtube.com](https://m.youtube.com) [[m.youtube.com](https://m.youtube.com)]

- 3. CN114907234B - Preparation method of 2-fluoro-5-formylbenzonitrile - Google Patents [[patents.google.com](https://patents.google.com)]
- 4. CN110105193B - Synthetic method of 2-halogen-5-bromobenzoic acid - Google Patents [[patents.google.com](https://patents.google.com)]
- 5. US11001552B2 - Method for preparation of 5-fluoro-2-methyl-3-nitrobenzoic acid and its methyl ester - Google Patents [[patents.google.com](https://patents.google.com)]
- 6. Development of a Buchwald–Hartwig Amination for an Accelerated Library Synthesis of Cereblon Binders - PMC [[pmc.ncbi.nlm.nih.gov](https://pubmed.ncbi.nlm.nih.gov)]
- 7. [mdpi.com](https://mdpi.com) [[mdpi.com](https://mdpi.com)]
- 8. [researchgate.net](https://researchgate.net) [[researchgate.net](https://researchgate.net)]
- 9. New 2-(aryl/heteroaryl)-6-(morpholin-4-yl/pyrrolidin-1-yl)-(4-trifluoromethyl)quinolines: synthesis via Buchwald–Hartwig amination, photophysics, and biomolecular binding properties - New Journal of Chemistry (RSC Publishing) [[pubs.rsc.org](https://pubs.rsc.org)]
- 10. Microwave-Assisted Buchwald–Hartwig Double Amination: A Rapid and Promising Approach for the Synthesis of TADF Compounds - PMC [[pmc.ncbi.nlm.nih.gov](https://pubmed.ncbi.nlm.nih.gov)]
- 11. [researchgate.net](https://researchgate.net) [[researchgate.net](https://researchgate.net)]
- 12. Organic Syntheses Procedure [[orgsyn.org](https://orgsyn.org)]
- 13. [researchgate.net](https://researchgate.net) [[researchgate.net](https://researchgate.net)]
- To cite this document: BenchChem. [Technical Support Center: Synthesis of 5-Fluoro-2-morpholinobenzoic Acid]. BenchChem, [2026]. [Online PDF]. Available at: [<https://www.benchchem.com/product/b1438663/docs#technical-support-center-synthesis-of-5-fluoro-2-morpholinobenzoic-acid>]

---

### Disclaimer & Data Validity:

The information provided in this document is for Research Use Only (RUO) and is strictly not intended for diagnostic or therapeutic procedures. While BenchChem strives to provide accurate protocols, we make no warranties, express or implied, regarding the fitness of this product for every specific experimental setup.

**Technical Support:** The protocols provided are for reference purposes. Unsure if this reagent suits your experiment?

**Need Industrial/Bulk Grade?** [Request Custom Synthesis Quote](#)

# BenchChem

Our mission is to be the trusted global source of essential and advanced chemicals, empowering scientists and researchers to drive progress in science and industry.

## Contact

Address: 3281 E Guasti Rd

Ontario, CA 91761, United States

Phone: (601) 213-4426

Email: [info@benchchem.com](mailto:info@benchchem.com)

[Contact our Ph.D. Support Team for a compatibility check](#)