

Beyond the Spectrum: A Comparative Guide to Structural Verification via 2D NMR Architectures

Author: BenchChem Technical Support Team. **Date:** May 2026

Compound of Interest

Compound Name: Ethyl 6-formylpyridine-2-carboxylate
CAS No.: 21908-10-1
Cat. No.: B1438563

[Get Quote](#)

Executive Summary: The Crisis of Connectivity

In drug discovery, a structure misassignment is not merely a clerical error; it is a sunk-cost catastrophe. While Mass Spectrometry (MS) confirms what is present, and X-ray Crystallography confirms how it is arranged in a lattice, only 2D Nuclear Magnetic Resonance (NMR) provides the solution-state dynamic proof of connectivity required for biological relevance.

This guide moves beyond basic spectral interpretation. We objectively compare high-fidelity 2D NMR pulse sequences against standard alternatives, establishing a self-validating protocol for verifying complex organic structures.

Comparative Analysis of 2D NMR Modalities

To verify a structure, we must interrogate two distinct architectures: the scalar coupling network (through-bond) and the dipolar coupling network (through-space).

A. The Homonuclear Suite (Proton-Proton Connectivity)

The choice between COSY, TOCSY, and NOESY is dictated by the density of the spin system and the specific structural question.

Feature	COSY (Correlation Spectroscopy)	TOCSY (Total Correlation Spectroscopy)	NOESY (Nuclear Overhauser Effect)
Mechanism	Scalar Coupling	Isotropic Mixing (Hartmann-Hahn)	Dipolar Coupling (Through-space)
Range	2-3 Bonds (Neighbors only)	Entire Spin System (Relay transfer)	< 5 Å spatial proximity
Critical Use	Establishing immediate connectivity.	Resolving overlapping multiplets in complex chains (e.g., sugars, peptides).	Determining Relative Stereochemistry and conformation.
Limitation	Fails in "spin-isolated" systems; crowded diagonal.	Mixing time () dependent; RF heating risks.	Requires careful mixing time optimization to avoid spin diffusion.

Expert Insight: Do not default to COSY for crowded spectra. Modern 2D TOCSY with a short mixing time (20-40 ms) often provides cleaner "COSY-like" data with better phase characteristics, while long mixing times (80-120 ms) reveal the full spin network.

B. The Heteronuclear Suite (The Carbon Skeleton)

This is where the skeleton of the molecule is built. The comparison here is between sensitivity and connectivity depth.

Feature	HSQC (Heteronuclear Single Quantum Coherence)	HMBC (Heteronuclear Multiple Bond Correlation)	1,1-ADEQUATE
Connectivity	1-Bond ()	2-3 Bonds ()	Direct C-C Connectivity ()
Sensitivity	High (Proton Detected)	Medium	Low (0.01% natural abundance)
The "Why"	Maps protons to specific carbons. ^{[1][2]} [3][4] Multiplicity- Edited HSQC distinguishes CH/CH (up) from CH (down).	The "Superglue" of NMR. Connects isolated spin systems across heteroatoms (O, N).	The Nuclear Option. Resolves HMBC ambiguity (2-bond vs 3-bond) by tracing the carbon backbone directly.

Causality in Protocol: Standard HMBC is often ambiguous because it cannot definitively distinguish between a 2-bond (

) and a 3-bond (

) correlation. If a quaternary carbon assignment is critical and HMBC is inconclusive, 1,1-ADEQUATE is the mandatory alternative, despite the time cost, as it filters for direct Carbon-Carbon bonds via double-quantum coherence.

Strategic Comparison: 2D NMR vs. Alternatives

How does 2D NMR stack up against orthogonal structural verification methods?

Table 1: Structural Verification Decision Matrix

Metric	2D NMR Suite	X-Ray Crystallography	High-Res Mass Spec (HRMS)
Primary Output	Atom-to-atom connectivity & relative stereochem.	Absolute 3D configuration & bond lengths.	Molecular formula & fragmentation pattern.
Sample State	Solution (native-like).	Solid Crystal (lattice packing forces).	Gas Phase (ionized).
Constraint	Requires solubility; difficulty with overlapping signals.	Requires Crystals. (The major bottleneck).[5]	"Blind" to connectivity of isomers.
Stereochemistry	Relative (NOE). Absolute requires derivatization (Mosher's).	Absolute (Gold Standard).	None.
Throughput	Medium (1-12 hours).	Low (Days to Weeks).	High (Minutes).[4][6][7]

Verdict: HRMS is a screening tool; X-ray is the ultimate validator but is often logistically impossible (amorphous solids, oils). 2D NMR is the operational workhorse that bridges the gap, providing 95% confidence without the need for crystallization.

The Self-Validating Protocol (SVP)

To ensure scientific integrity, we employ a workflow where each experiment validates the previous one. This prevents "confirmation bias" where a researcher forces a structure to fit the data.

Step 1: The Foundation (1D & HSQC)

- Acquire high S/N

H NMR and Multiplicity-Edited HSQC.

- Validation: Sum of HSQC integrals must match proton count. All protonated carbons are now mapped.

Step 2: The Skeleton (HMBC & COSY)

- Use COSY to establish proton spin systems.[\[6\]](#)[\[8\]](#)[\[9\]](#)[\[10\]](#)
- Use HMBC to bridge these systems across quaternary carbons and heteroatoms.
- Validation: Every HMBC correlation must be chemically logical (2-4 bonds).

Step 3: The Stereochemical Lock (NOESY/ROESY)

- Once connectivity is locked, use NOESY for spatial arrangement.[\[9\]](#)
- Validation: NOE signals must only appear between protons $<5\text{\AA}$ apart in the proposed model.

Step 4: The Ambiguity Breaker (ADEQUATE/NUS)

- If HMBC allows multiple isomers, deploy 1,1-ADEQUATE or Pure Shift techniques.

Visualizing the Workflow

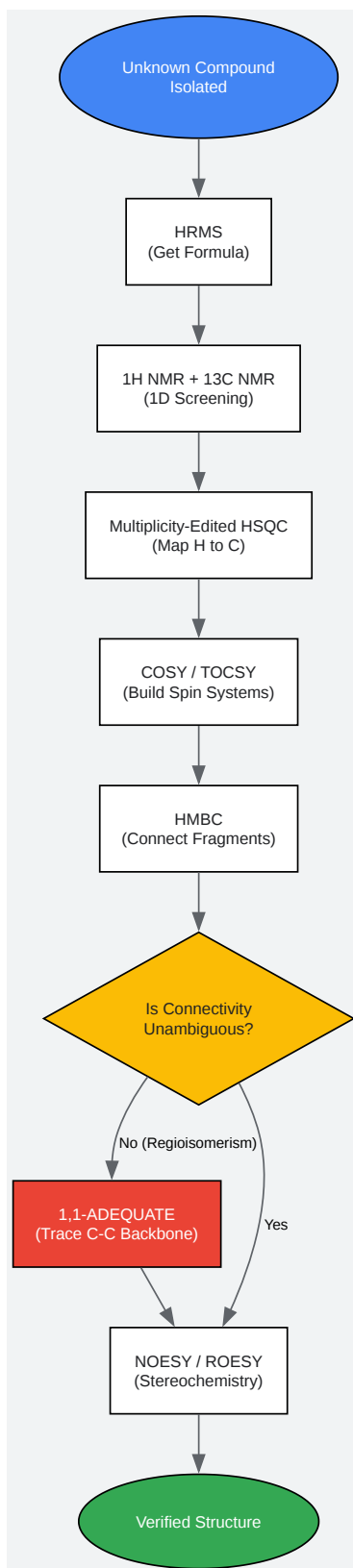

[Click to download full resolution via product page](#)

Figure 1: The Self-Validating NMR Workflow. Note the critical decision branch for utilizing ADEQUATE sequences when HMBC data is inconclusive.

Experimental Causality: Solving Regioisomerism

A common failure mode in drug development is distinguishing between regioisomers (e.g., substitution at position 5 vs. 6 on an indole ring).

The Problem: HMBC Ambiguity

In aromatic systems, HMBC correlations (

) are often observed across multiple pathways. A proton might show a correlation to a carbon that is 3 bonds away via two different routes, making assignment "fuzzy."

The Solution: 1,1-ADEQUATE Logic

The 1,1-ADEQUATE sequence filters magnetization to strictly observe 1-bond Carbon-Carbon () couplings.

- Magnetization Transfer:

(via

)

Adjacent

(via

double quantum).

- Result: You only see correlations between a proton and the immediate neighboring carbons of the carbon it is attached to.
- Data Interpretation: If Proton A correlates to Carbon B in ADEQUATE, Carbon B must be directly bonded to Carbon A's host. This eliminates the "2-bond vs 3-bond" guess.

Visualization of Magnetization Transfer[10]

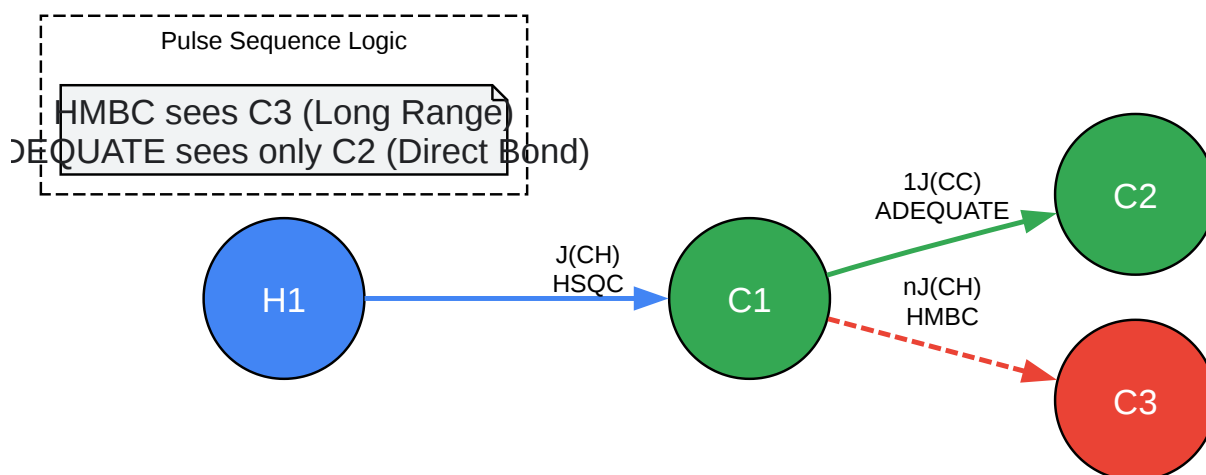

[Click to download full resolution via product page](#)

Figure 2: Logical distinction between HMBC (long-range, ambiguous) and ADEQUATE (direct bond, specific) pathways.

References

- IUPAC Recommendations for NMR Data Presentation Markley, J. L., et al. "Recommendations for the presentation of NMR structures of proteins and nucleic acids." [11] Pure and Applied Chemistry, 1998. [12] [\[Link\]](#)
- The 1,1-ADEQUATE Experiment Reif, B., Köck, M., & Kerssebaum, R. "ADEQUATE: A new set of experiments to determine the constitution of small molecules at natural abundance." Journal of Magnetic Resonance, 1996. [\[Link\]](#)
- Pure Shift NMR Spectroscopy Zangger, K. "Pure shift NMR spectroscopy." [13][14][15] Progress in Nuclear Magnetic Resonance Spectroscopy, 2015. [\[Link\]](#)
- Comparison of NMR and X-ray Crystallography Smyth, M. S., & Martin, J. H. [16] "x Ray crystallography." [5][17] Molecular Pathology, 2000. [\[Link\]](#)
- Small Molecule Structure Elucidation Guide Claridge, T. D. W. High-Resolution NMR Techniques in Organic Chemistry. 3rd Edition, Elsevier, 2016. [\[Link\]](#)

Need Custom Synthesis?

BenchChem offers custom synthesis for rare earth carbides and specific isotopic labeling.

Email: info@benchchem.com or [Request Quote Online](#).

Sources

- [1. researchgate.net \[researchgate.net\]](https://www.researchgate.net)
- [2. HMBC-1,n-ADEQUATE spectra calculated from HMBC and 1,n-ADEQUATE spectra - PubMed \[pubmed.ncbi.nlm.nih.gov\]](#)
- [3. researchgate.net \[researchgate.net\]](https://www.researchgate.net)
- [4. Comparison of H2BC and 1,1-ADEQUATE | Applications Notes | JEOL Ltd. \[jeol.com\]](#)
- [5. chemistry.stackexchange.com \[chemistry.stackexchange.com\]](https://chemistry.stackexchange.com)
- [6. 7\) Common 2D \(COSY, HSQC, HMBC\) | SDSU NMR Facility – Department of Chemistry \[nmr.sdsu.edu\]](#)
- [7. eqnmr.hms.harvard.edu \[eqnmr.hms.harvard.edu\]](https://eqnmr.hms.harvard.edu)
- [8. princeton.edu \[princeton.edu\]](https://www.princeton.edu)
- [9. creative-biostructure.com \[creative-biostructure.com\]](https://www.creative-biostructure.com)
- [10. 2D NMR \[chem.ch.huji.ac.il\]](https://chem.ch.huji.ac.il)
- [11. Recommendations for the presentation of NMR structures of proteins and nucleic acids. IUPAC-IUBMB-IUPAB Inter-Union Task Group on the Standardization of Data Bases of Protein and Nucleic Acid Structures Determined by NMR Spectroscopy - PubMed \[pubmed.ncbi.nlm.nih.gov\]](#)
- [12. feh.scs.illinois.edu \[feh.scs.illinois.edu\]](https://feh.scs.illinois.edu)
- [13. Pure Shift 2D NMR Spectroscopy | Manchester NMR Methodology Group \[nmr.chemistry.manchester.ac.uk\]](#)
- [14. books.rsc.org \[books.rsc.org\]](https://books.rsc.org)
- [15. Pure Shift NMR \[uwyo.edu\]](https://uwyo.edu)
- [16. quora.com \[quora.com\]](https://www.quora.com)
- [17. creative-biostructure.com \[creative-biostructure.com\]](https://www.creative-biostructure.com)

- To cite this document: BenchChem. [Beyond the Spectrum: A Comparative Guide to Structural Verification via 2D NMR Architectures]. BenchChem, [2026]. [Online PDF]. Available at: [<https://www.benchchem.com/product/b1438563/docs#beyond-the-spectrum-a-comparative-guide-to-structural-verification-via-2d-nmr-architectures>]

Disclaimer & Data Validity:

The information provided in this document is for Research Use Only (RUO) and is strictly not intended for diagnostic or therapeutic procedures. While BenchChem strives to provide accurate protocols, we make no warranties, express or implied, regarding the fitness of this product for every specific experimental setup.

Technical Support: The protocols provided are for reference purposes. Unsure if this reagent suits your experiment?

Need Industrial/Bulk Grade? [Request Custom Synthesis Quote](#)

BenchChem

Our mission is to be the trusted global source of essential and advanced chemicals, empowering scientists and researchers to drive progress in science and industry.

Contact

Address: 3281 E Guasti Rd
Ontario, CA 91761, United States
Phone: (601) 213-4426
Email: info@benchchem.com

[Contact our Ph.D. Support Team for a compatibility check](#)