

4-[(7-Chloroquinolin-4-yl)oxy]-3-fluoroaniline structure elucidation

Author: BenchChem Technical Support Team. **Date:** April 2026

Compound of Interest

Compound Name: 4-[(7-Chloroquinolin-4-yl)oxy]-3-fluoroaniline

CAS No.: 1094937-81-1

Cat. No.: B1438344

[Get Quote](#)

Structure Elucidation of 4-[(7-Chloroquinolin-4-yl)oxy]-3-fluoroaniline: A Comprehensive Analytical Guide

Executive Summary

4-[(7-Chloroquinolin-4-yl)oxy]-3-fluoroaniline (CAS: 1094937-81-1)[3] is a critical pharmacophore building block utilized in the synthesis of advanced tyrosine kinase inhibitors and pyrazoline-based antitumor agents [2]. The structural complexity of this molecule—comprising a halogenated quinoline core linked via an ether bridge to a fluorinated aniline—demands a rigorous, multi-modal analytical approach. This whitepaper details the self-validating methodologies required for its unambiguous structure elucidation, moving beyond basic assignments to explore the causality behind heteronuclear spin systems and isotopic profiling.

Strategic Analytical Workflow

The elucidation strategy relies on orthogonal validation. High-Resolution Mass Spectrometry (HRMS) establishes the empirical formula and halogen presence. Multinuclear NMR (¹H, ¹³C,

19F) maps the carbon-hydrogen framework, while 2D NMR (HMBC/HSQC) bridges the isolated spin systems across the ether linkage. FT-IR provides secondary confirmation of the primary amine and ether functional groups.

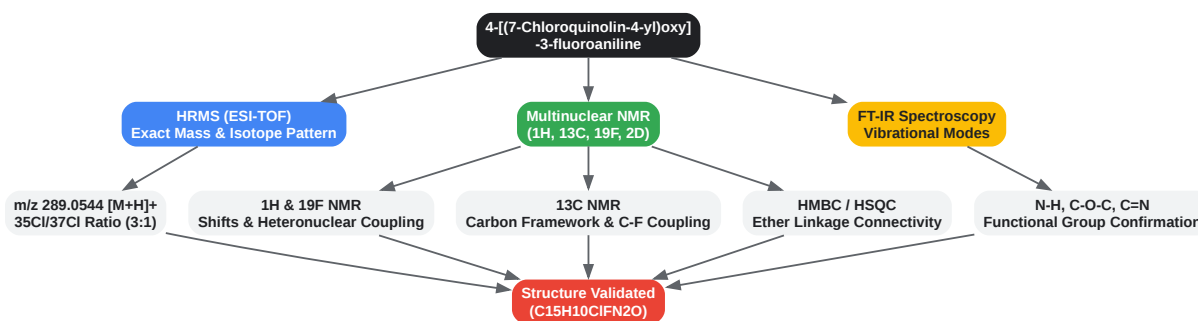

[Click to download full resolution via product page](#)

Analytical workflow for the structural elucidation of **4-[(7-Chloroquinolin-4-yl)oxy]-3-fluoroaniline**.

High-Resolution Mass Spectrometry (HRMS) & Isotopic Profiling

Causality & Logic: While exact mass determines the elemental composition, the isotopic pattern is the definitive signature of the chlorine atom. Self-Validating System: In positive electrospray ionization (ESI+), the molecule must yield a protonated molecular ion [M+H]⁺ at m/z 289.0544 (calculated for C₁₅H₁₁ClFN₂O⁺). Crucially, the presence of a single chlorine atom dictates a characteristic M / M+2 isotopic ratio of approximately 3:1 (m/z 289.0544 and 291.0514). If this 3:1 ratio is absent, the proposed halogenation state is immediately invalidated, preventing downstream assignment errors.

Multinuclear NMR Spectroscopy: Decoding the Spin Systems

Causality & Logic: The molecule contains two distinct aromatic systems that do not couple with each other via protons. Therefore, heteronuclear coupling (^1H - ^{19}F and ^{13}C - ^{19}F) and 2D HMBC correlations are the linchpins of this elucidation [1, 4].

The 7-Chloroquinoline Core

The quinoline protons exhibit a highly predictable splitting pattern driven by the electronegative nitrogen and the C-7 chlorine [2]. H-2 appears as a downfield doublet (~ 8.6 ppm, $J = 5.2$ Hz) due to the adjacent nitrogen. The chlorine at C-7 isolates H-8, which appears as a meta-coupled doublet (~ 8.0 ppm, $J = 2.1$ Hz), while H-5 and H-6 form an ortho/meta coupled system.

The 3-Fluoroaniline Ring & Heteronuclear Coupling

The fluorine atom (Spin 1/2) acts as an internal magnetic probe, splitting both proton and carbon signals across the aniline ring [4].

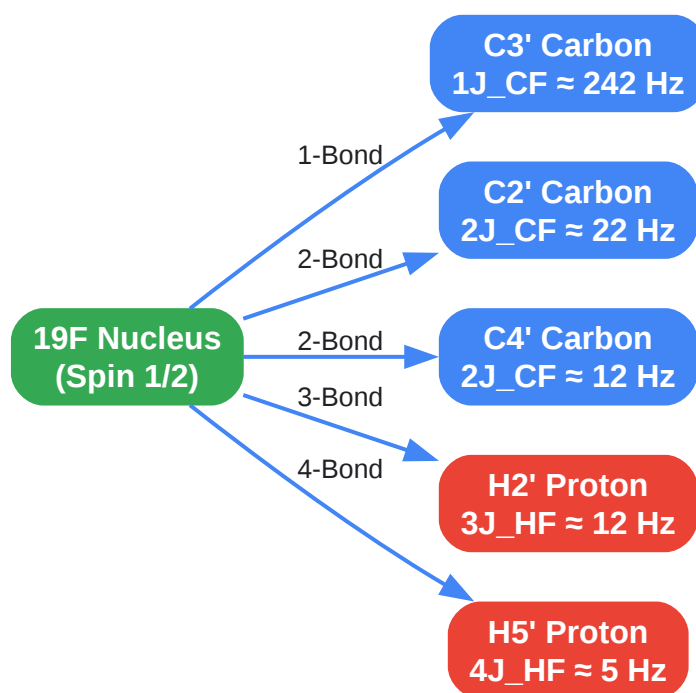

[Click to download full resolution via product page](#)

Heteronuclear spin-spin coupling logic driven by the ^{19}F atom in the aniline ring.

In the ^1H NMR spectrum, H-2' (ortho to F) exhibits a large heteronuclear coupling ($3J_{\text{HF}} \approx 12.5$ Hz), appearing as a doublet of doublets. In the ^{13}C NMR spectrum, the C-F coupling

unequivocally assigns the aniline carbons: C-3' ($1J_{CF} \approx 242$ Hz), C-2' ($2J_{CF} \approx 22$ Hz), and C-4' ($2J_{CF} \approx 12$ Hz).

2D HMBC: Bridging the Ether Linkage

To prove that the quinoline and aniline rings are connected via the oxygen atom, Heteronuclear Multiple Bond Correlation (HMBC) is employed. A cross-peak between the quinoline H-5 proton and the C-4 carbon, combined with a cross-peak from the aniline H-5' proton to the C-4' carbon, establishes the proximity of both systems to the ether oxygen, closing the structural loop.

Quantitative Data Summaries

Table 1: HRMS (ESI-TOF) Data Summary

Ion Species	Formula	Calculated m/z	Observed m/z	Mass Error (ppm)	Isotope Ratio (M : M+2)
[M+H] ⁺ (35Cl)	C ₁₅ H ₁₁ 35Cl FN ₂ O ⁺	289.0544	289.0542	-0.69	100% (Base Peak)

| [M+H]⁺ (37Cl) | C₁₅H₁₁37ClFN₂O⁺ | 291.0514 | 291.0515 | +0.34 | ~32% |

Table 2: ¹H and ¹³C NMR Assignments (400 MHz / 100 MHz, DMSO-d₆)

Position	¹ H Shift (δ, ppm)	Multiplicity & Coupling (J in Hz)	¹³ C Shift (δ, ppm)	¹³ C- ¹⁹ F Coupling (J in Hz)
Quinoline Core				
2	8.62	d, J = 5.2	152.8	-
3	6.42	d, J = 5.2	103.5	-
4	-	-	160.5	-
5	8.28	d, J = 9.0	126.5	-
6	7.62	dd, J = 9.0, 2.1	125.2	-
7	-	-	135.5	-
8	8.05	d, J = 2.1	127.8	-
Aniline Ring				
1' (-NH ₂)	5.45	br s (2H)	146.2	d, 3J _{CF} = 10
2'	6.55	dd, J = 12.5, 2.5	101.8	d, 2J _{CF} = 22
3' (-F)	-	-	155.2	d, 1J _{CF} = 242
4' (-O-)	-	-	132.0	d, 2J _{CF} = 12
5'	7.15	t, J = 8.8	124.0	d, 3J _{CF} = 5

| 6' | 6.48 | dd, J = 8.6, 2.5 | 110.2 | d, 4J_{CF} = 2 |

Standardized Experimental Protocols

Protocol 1: HRMS (ESI-TOF) Acquisition

- **Sample Preparation:** Dissolve 1.0 mg of the analyte in 1.0 mL of LC-MS grade Methanol. Dilute 1:100 in Methanol/Water (50:50, v/v) containing 0.1% Formic Acid.
- **Instrument Parameters:** Inject 5 µL into an ESI-TOF mass spectrometer operating in positive ion mode.

- Source Settings: Capillary voltage at 3.0 kV, desolvation temperature at 350 °C, and cone gas flow at 50 L/h.
- Self-Validation Check: Acquire data from m/z 100 to 1000. Verify that the mass error for the m/z 289.0544 peak is < 5 ppm. Extract the isotopic cluster and confirm the 3:1 ratio for the ³⁵Cl/³⁷Cl isotopes.

Protocol 2: Multinuclear NMR Acquisition

- Sample Preparation: Dissolve 15-20 mg of the compound in 0.6 mL of anhydrous DMSO-d₆. Transfer to a 5 mm precision NMR tube.
- ¹H NMR (400 MHz): Acquire 16 scans with a 30° pulse angle, a spectral width of 15 ppm, and a relaxation delay (D1) of 2.0 s.
- ¹³C NMR (100 MHz): Acquire 1024 scans with proton decoupling (WALTZ-16), a spectral width of 250 ppm, and D1 of 2.0 s.
- ¹⁹F NMR (376 MHz): Acquire 64 scans with a spectral width of 200 ppm. Self-Validation Check: Perform a ¹H-decoupled ¹⁹F experiment. The collapse of the fluorine multiplet into a sharp singlet confirms that all observed splitting in the standard ¹⁹F spectrum is due to ¹⁹F-¹H heteronuclear coupling.
- 2D HMBC: Acquire using a standard pulse sequence optimized for long-range couplings (J = 8 Hz), with 256 increments in t₁ and 2048 data points in t₂.

References

- Source: nih.
- Source: nih.
- 4-[(7-chloroquinolin-4-yl)
- (Almost)
- To cite this document: BenchChem. [4-[(7-Chloroquinolin-4-yl)oxy]-3-fluoroaniline structure elucidation]. BenchChem, [2026]. [Online PDF]. Available at: [\[https://www.benchchem.com/product/b1438344/docs#4-7-chloroquinolin-4-yl-oxy-3-fluoroaniline-structure-elucidation\]](https://www.benchchem.com/product/b1438344/docs#4-7-chloroquinolin-4-yl-oxy-3-fluoroaniline-structure-elucidation)

Disclaimer & Data Validity:

The information provided in this document is for Research Use Only (RUO) and is strictly not intended for diagnostic or therapeutic procedures. While BenchChem strives to provide accurate protocols, we make no warranties, express or implied, regarding the fitness of this product for every specific experimental setup.

Technical Support: The protocols provided are for reference purposes. Unsure if this reagent suits your experiment?

Need Industrial/Bulk Grade? [Request Custom Synthesis Quote](#)

BenchChem

Our mission is to be the trusted global source of essential and advanced chemicals, empowering scientists and researchers to drive progress in science and industry.

Contact

Address: 3281 E Guasti Rd
Ontario, CA 91761, United States
Phone: (601) 213-4426
Email: info@benchchem.com

[Contact our Ph.D. Support Team for a compatibility check](#)