

Application Note: Mass Spectrometry Profiling of -Amino Ketones

Author: BenchChem Technical Support Team. **Date:** May 2026

Compound of Interest

Compound Name: 2-Anilino-1-(9H-fluoren-2-yl)ethan-1-one
CAS No.: 88093-09-8
Cat. No.: B14378441

[Get Quote](#)

Subject: Structural Elucidation, Isomer Differentiation, and Bioanalysis of

-Amino Ketones (Synthetic Cathinones) Date: October 26, 2023 Author: Senior Application Scientist, Mass Spectrometry Division

Introduction

-Amino ketones are a chemically versatile class of compounds characterized by a ketone group with an amine substituent on the alpha carbon. While they serve as critical intermediates in pharmaceutical synthesis, their most prominent analytical relevance lies in forensic toxicology and drug development, specifically regarding synthetic cathinones (beta-keto amphetamines).

This guide addresses the primary analytical challenges associated with this class: thermal instability, isobaric heterogeneity (regioisomers), and matrix interference in biological samples. It provides a validated framework for moving from raw sample to definitive structural identification using both GC-MS and LC-MS/MS platforms.[1]

Mechanistic Principles of Fragmentation

Understanding the gas-phase ion chemistry of

-amino ketones is prerequisite to interpreting their mass spectra. The fragmentation is driven by the radical site initiation (in EI) or charge-remote/charge-proximate interactions (in ESI).

Electron Ionization (EI) - GC-MS

In standard 70 eV EI,

-amino ketones undergo a predictable and dominant fragmentation pathway known as

-cleavage.

- Ionization: Removal of an electron from the nitrogen lone pair (lowest ionization energy) yields the molecular ion
.
- -Cleavage: The radical cation triggers homolytic cleavage of the C-C bond between the carbonyl carbon and the
-carbon.[2]
- Iminium Ion Formation: This results in a resonance-stabilized iminium ion (base peak) and a neutral acyl radical.

Diagnostic Value: The mass of the iminium ion (

44, 58, 72, etc.) reveals the substitution pattern on the nitrogen and the

-carbon, but loses information about the aromatic ring substituents in cathinone analogs.

Electrospray Ionization (ESI) - LC-MS/MS

In positive mode ESI (

), fragmentation is less explosive than EI.

- Water Loss: A common neutral loss, particularly in cathinones, is

(

), often followed by the loss of the amine.

- Heterolytic Cleavage: Collision-Induced Dissociation (CID) often cleaves the bond between the α -carbon and the aromatic ring, preserving the aromatic moiety in the charged fragment (unlike EI). This makes LC-MS/MS superior for identifying ring substituents (e.g., fluorinated analogs).

Visualization: Fragmentation Pathways

The following diagram illustrates the divergent pathways between EI and ESI for a generic α -amino ketone.

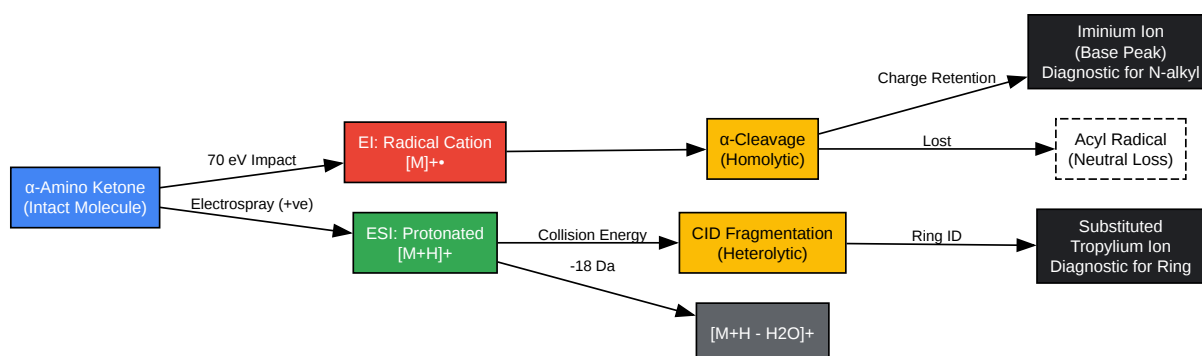

[Click to download full resolution via product page](#)

Caption: Comparative fragmentation pathways. EI favors iminium ion formation (side-chain ID), while ESI/CID often retains ring-specific fragments.

Method Development: GC-MS vs. LC-MS/MS

One of the most critical decisions in

α -amino ketone analysis is platform selection. These compounds are thermally labile.[3] In GC injection ports, they can undergo oxidative degradation (dehydrogenation) to form enamines or corresponding 1,2-diones.

Comparative Analysis Table

Feature	GC-MS (EI)	LC-MS/MS (ESI)
Analyte Stability	Low. Risk of thermal degradation in injector (C).	High. Analysis occurs in solution at ambient/moderate temps.
Derivatization	Required (e.g., TFAA, PFPA) to improve stability and peak shape.	Not Required. Direct analysis of polar compounds.
Isomer Resolution	Excellent. Chromatographic resolution of positional isomers is often superior.	Moderate. Requires long gradients or chiral columns for enantiomers.
Sensitivity	ng/mL range. ^{[4][5]}	pg/mL range (Superior for trace toxicology).
Structural Data	Library matchable (NIST/SWGDRUG).	Precursor/Product ion logic required.

Expert Recommendation: Use LC-MS/MS for quantitative bioanalysis (plasma/urine) to avoid degradation artifacts. Use GC-MS (with derivatization) for confirmatory identification of seized drug powders where isomeric discrimination is paramount.^[6]

Protocol: Extraction and Analysis from Plasma

This protocol utilizes Mixed-Mode Strong Cation Exchange (MCX) Solid Phase Extraction (SPE).

-Amino ketones are basic (

); therefore, a mechanism utilizing both hydrophobic retention (ring structure) and ionic retention (amine) provides the highest purity.

Materials

- SPE Cartridges: Mixed-mode cation exchange (e.g., Oasis MCX or Strata-X-C), 30 mg/1 mL.
- Internal Standard (IS): Deuterated analog (e.g., Mephedrone-d3), 100 ng/mL in methanol.

- LC Mobile Phases:
 - A: 0.1% Formic Acid in Water (Proton source).
 - B: 0.1% Formic Acid in Acetonitrile.[6]

Step-by-Step Workflow

- Sample Pre-treatment:
 - Aliquot 200
L plasma.[6]
 - Add 20
L Internal Standard.
 - Add 200
L
(Acidification ensures amine is protonated for cation exchange).
 - Vortex 30s and centrifuge.
- SPE Extraction (MCX):
 - Condition: 1 mL Methanol
1 mL Water.
 - Load: Apply pre-treated sample (gravity or low vacuum).
 - Wash 1 (Acidic): 1 mL 2% Formic Acid (Removes proteins/acidic interferences).
 - Wash 2 (Organic): 1 mL Methanol (Removes neutral/hydrophobic interferences). Crucial: The analyte remains bound by ionic interaction.
 - Elute: 1 mL 5%

in Methanol (Breaks ionic bond by deprotonating the amine).

- Reconstitution:
 - Evaporate eluate to dryness under

at

C.
 - Reconstitute in 100

L Mobile Phase (95:5 A:B).

LC-MS/MS Parameters (Example for Triple Quad)

- Column: C18 Reverse Phase (e.g., 2.1 x 100 mm, 1.7

m).
- Flow Rate: 0.3 mL/min.
- Gradient: 5% B to 95% B over 8 minutes.
- Source: ESI Positive.[4] Capillary: 3.0 kV. Temp:

C.
- MRM Transitions:
 - Quantifier:

(or iminium equivalent).
 - Qualifier:

Tropylium ion (Ring fragment).

Visualization: Validated Workflow

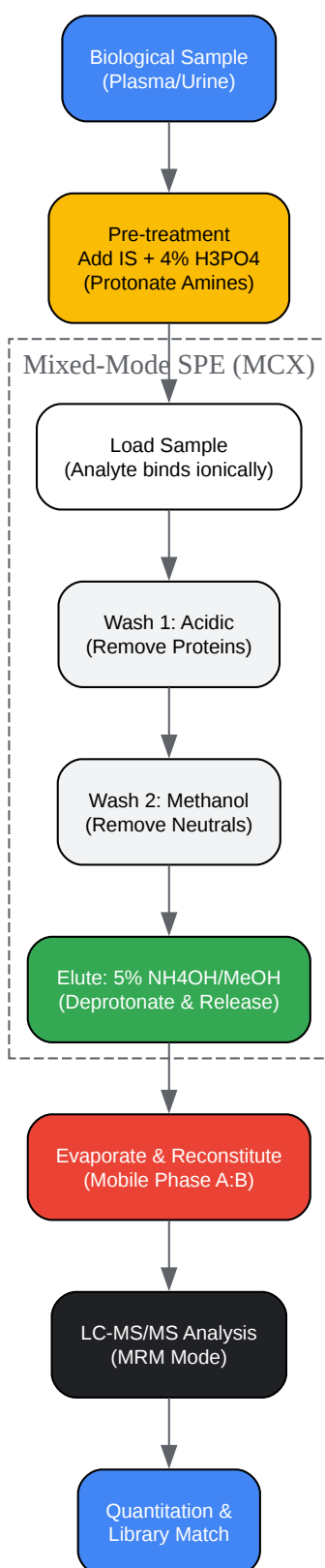

[Click to download full resolution via product page](#)

Caption: MCX SPE workflow ensuring high recovery of basic

-amino ketones while removing matrix interferences.

Advanced Topic: Differentiation of Regioisomers

A major challenge in this field is distinguishing positional isomers (e.g., 3-MMC vs. 4-MMC). These molecules have identical molecular weights and often identical major fragment ions.

Solution Strategy:

- **Chromatographic Separation:** Utilizing biphenyl or pentafluorophenyl (PFP) stationary phases in LC often provides better selectivity for positional isomers than standard C18 due to interactions.
- **Ion Ratio Analysis:** While major fragments are identical, the ratio of relative abundances often differs.
 - Protocol: Establish a "Qualifying Ratio" () based on certified reference material.
- **Electron Activated Dissociation (EAD):** Recent advances utilizing EAD (ZenoTOF) have shown the ability to generate unique radical fragments that distinguish ring substitution patterns which are indistinguishable by standard CID [1].

References

- Davidson, J. T., et al. (2024).[7] Identification of synthetic cathinone positional isomers using electron activated dissociation mass spectrometry. *Analytica Chimica Acta*. [Link](#)
- UNODC. (2021). Recommended Methods for the Identification and Analysis of Synthetic Cathinones. United Nations Office on Drugs and Crime. [Link](#)
- Scientific Working Group for the Analysis of Seized Drugs (SWGDRUG). (2023). SWGDRUG Mass Spectral Library. [Link](#)
- Kohyama, E., et al. (2016). Differentiation of the Isomers of N-Alkylated Cathinones by GC-EI-MS-MS and LC-PDA. *Analytical Sciences*. [Link](#)

- Phenomenex. (2020). Solid Phase Extraction (SPE) Guide for Clinical Research. [Link](#)

Need Custom Synthesis?

BenchChem offers custom synthesis for rare earth carbides and specific isotopic labeling.

Email: info@benchchem.com or [Request Quote Online](#).

Sources

- 1. Differentiation of the Isomers of N-Alkylated Cathinones by GC-EI-MS-MS and LC-PDA - PubMed [pubmed.ncbi.nlm.nih.gov]
- 2. Alpha (α) Cleavage - Chemistry Steps [chemistrysteps.com]
- 3. ojp.gov [ojp.gov]
- 4. phenomenex.com [phenomenex.com]
- 5. moca.net.ua [moca.net.ua]
- 6. chromatographyonline.com [chromatographyonline.com]
- 7. Identification of synthetic cathinone positional isomers using electron activated dissociation mass spectrometry - PubMed [pubmed.ncbi.nlm.nih.gov]
- To cite this document: BenchChem. [Application Note: Mass Spectrometry Profiling of - Amino Ketones]. BenchChem, [2026]. [Online PDF]. Available at: [https://www.benchchem.com/product/b14378441/docs#application-note-mass-spectrometry-profiling-of-amino-ketones]

Disclaimer & Data Validity:

The information provided in this document is for Research Use Only (RUO) and is strictly not intended for diagnostic or therapeutic procedures. While BenchChem strives to provide accurate protocols, we make no warranties, express or implied, regarding the fitness of this product for every specific experimental setup.

Technical Support: The protocols provided are for reference purposes. Unsure if this reagent suits your experiment?

Need Industrial/Bulk Grade? [Request Custom Synthesis Quote](#)

BenchChem

Our mission is to be the trusted global source of essential and advanced chemicals, empowering scientists and researchers to drive progress in science and industry.

Contact

Address: 3281 E Guasti Rd

Ontario, CA 91761, United States

Phone: (601) 213-4426

Email: info@benchchem.com

[Contact our Ph.D. Support Team for a compatibility check](#)