

Technical Support Center: Navigating the Challenges of Sterically Hindered Boronic Acids

Author: BenchChem Technical Support Team. **Date:** May 2026

Compound of Interest

Compound Name: (6-Phenylnaphthalen-2-yl)boronic acid
CAS No.: 876442-90-9
Cat. No.: B6327070

[Get Quote](#)

Welcome to the technical support center dedicated to overcoming the complexities of cross-coupling reactions involving sterically hindered boronic acids. This guide is designed for researchers, scientists, and professionals in drug development who encounter challenges with low reactivity and poor yields in Suzuki-Miyaura coupling reactions. Here, we provide field-proven insights, detailed troubleshooting protocols, and a comprehensive understanding of the underlying chemical principles to empower you to conquer these synthetic hurdles.

Frequently Asked Questions (FAQs)

Here are some of the most common questions our application scientists receive regarding sterically hindered boronic acids.

Q1: Why is my Suzuki-Miyaura coupling reaction with a sterically hindered boronic acid failing or giving low yields?

A1: Low reactivity in these cases is primarily due to steric hindrance, which impedes key steps in the catalytic cycle, particularly the transmetalation step. The bulky substituents on the

boronic acid (and/or the coupling partner) make it difficult for the boronic acid to approach and coordinate with the palladium center, thus slowing down or preventing the transfer of the organic group. Additionally, sterically hindered boronic acids are often more prone to decomposition pathways like protodeboronation, further reducing the concentration of the active coupling partner.[1]

Q2: What are the first troubleshooting steps I should take for a low-yielding reaction with a hindered boronic acid?

A2: When facing a low-yielding reaction, a systematic approach is crucial. Start by verifying the integrity of your reagents, especially the boronic acid, which can degrade upon storage. Ensure your reaction is rigorously deoxygenated, as oxygen can lead to unwanted side reactions like homocoupling. Then, focus on the "big three" reaction parameters: the ligand, the base, and the solvent. Often, a simple switch to a bulkier, more electron-rich ligand, a stronger, non-nucleophilic base, or a different solvent system can dramatically improve yields.

Q3: How do I choose the right ligand and catalyst for my sterically hindered substrate?

A3: For sterically demanding couplings, the choice of ligand is critical. Standard ligands like triphenylphosphine are often ineffective. You should opt for bulky, electron-rich monophosphine ligands, often referred to as Buchwald-type ligands. These ligands promote the formation of a monoligated, highly reactive Pd(0) species that is less sterically encumbered and can more readily undergo oxidative addition and facilitate the challenging transmetalation step. Examples include SPhos, XPhos, and RuPhos.[2] N-heterocyclic carbenes (NHCs) are also powerful alternatives for these challenging reactions.[3][4]

Q4: Can the choice of base significantly impact the reaction outcome?

A4: Absolutely. The base plays a crucial role in activating the boronic acid to form a more nucleophilic boronate species, which is necessary for transmetalation.[3] For hindered substrates, stronger bases are often required to drive this equilibrium. Common choices include potassium phosphate (K_3PO_4), cesium carbonate (Cs_2CO_3), and potassium tert-butoxide (KOtBu). The solubility of the base is also a key factor, which is influenced by the solvent system. For instance, K_3PO_4 is more effective in aqueous-organic solvent mixtures.

Q5: Are there alternative coupling methods for extremely hindered systems?

A5: Yes. If optimizing the Suzuki-Miyaura reaction proves unsuccessful, you might consider alternative cross-coupling reactions that are sometimes more tolerant of steric hindrance. The Negishi coupling (using organozinc reagents) or the Stille coupling (using organotin reagents) can be effective alternatives. Additionally, exploring different leaving groups on the electrophilic partner can sometimes open up more favorable reaction pathways.

In-depth Troubleshooting Guides

Systematic Guide to Optimizing Reaction Conditions for Hindered Boronic Acids

When initial attempts yield unsatisfactory results, a systematic optimization is necessary. The following guide provides a structured approach to identifying the optimal conditions for your specific substrates.

1. Reagent Stability and Quality Control:

- **Boronic Acid Integrity:** Sterically hindered boronic acids can be prone to decomposition. Before starting, it's advisable to check the purity of your boronic acid by NMR or LC-MS.
- **Stable Boronic Acid Surrogates:** If your boronic acid is known to be unstable, consider using more robust derivatives that release the boronic acid in situ. This "slow-release" strategy can minimize decomposition.^[5]
 - **Boronate Esters (e.g., pinacol, MIDA):** MIDA (N-methyliminodiacetic acid) boronates are exceptionally stable, crystalline solids that are compatible with a wide range of reaction conditions and can be easily deprotected under mild aqueous basic conditions.^{[5][6][7][8]}
 - **Potassium Trifluoroborate Salts (R-BF₃K):** These salts are highly stable, crystalline solids that are less susceptible to protodeboronation.
 - **Diethanolamine Adducts:** Complexing the boronic acid with diethanolamine creates an air- and water-stable crystalline solid that can be used directly in the coupling reaction.

2. The Catalytic System: Palladium Source and Ligand Selection:

The heart of a successful Suzuki-Miyaura coupling lies in the catalytic system. For hindered substrates, pre-formed palladium catalysts (precatalysts) are often more reliable than generating the active catalyst in situ.

Ligand Type	Examples	Key Characteristics & Applications
Buchwald Biarylphosphines	SPhos, XPhos, RuPhos	Bulky and electron-rich, promoting monoligation and facilitating oxidative addition and reductive elimination. The gold standard for many challenging couplings. [2] [9] [10] [11]
N-Heterocyclic Carbenes (NHCs)	IPr, SIMes	Strong σ -donors that form very stable complexes with palladium. Highly effective for coupling aryl chlorides and other challenging substrates. [3] [4]
Specialized Ligands	BI-DIME, AntPhos	Designed for extremely sterically demanding couplings, including the formation of tetra-ortho-substituted biaryls. [12]

3. The Role of the Base and Solvent System:

The base and solvent are intricately linked and must be optimized in tandem.

Base	Recommended Solvents	Comments
K ₃ PO ₄	Toluene/H ₂ O, Dioxane/H ₂ O	A strong, non-nucleophilic base. The presence of water is often crucial for its solubility and activity. ^{[13][14]}
Cs ₂ CO ₃	Dioxane, THF, Toluene	A highly effective base, often used in anhydrous conditions.
KOtBu	Toluene, THF	A very strong base, useful for particularly challenging couplings. Can be sensitive to functional groups.
K ₂ CO ₃	Toluene/Ethanol/H ₂ O	A milder base, sometimes sufficient and can be advantageous with base-sensitive functional groups.

4. Reaction Temperature and Concentration:

Sterically hindered reactions often require higher temperatures (80-120 °C) to overcome the activation energy barrier. However, excessively high temperatures can promote boronic acid decomposition. It is a delicate balance that needs to be empirically determined. Reaction concentration can also play a role, with more dilute conditions sometimes favoring the desired cross-coupling over side reactions.

Diagnosing and Preventing Boronic Acid Decomposition

The two most common decomposition pathways for boronic acids are protodeboronation and homocoupling.

- Protodeboronation: The replacement of the C-B bond with a C-H bond. This is often promoted by acidic or basic conditions and the presence of water.
 - Mitigation:
 - Use of stable boronic acid surrogates (MIDA esters, trifluoroborates).

- Careful selection of the base and minimizing reaction time.
- Running the reaction under anhydrous conditions if possible, though water is often necessary for base activity.^{[13][14]}
- Homocoupling: The dimerization of the boronic acid to form a biaryl byproduct. This is primarily caused by the presence of oxygen in the reaction mixture.
 - Mitigation:
 - Rigorous Degassing: Thoroughly degas all solvents (including water) and the reaction vessel by sparging with an inert gas (argon or nitrogen) or by using freeze-pump-thaw cycles.
 - Use of a Pd(0) Source: Starting with a Pd(0) catalyst, such as Pd(PPh₃)₄ or Pd₂(dba)₃, can be beneficial.

Experimental Protocols

General Protocol for Suzuki-Miyaura Coupling of a Sterically Hindered Boronic Acid

This is a general starting point and should be optimized for specific substrates.

- Reagent Preparation: In a glovebox or under an inert atmosphere, add the aryl halide (1.0 equiv), the sterically hindered boronic acid or its stable surrogate (1.2-1.5 equiv), the palladium precatalyst (e.g., XPhos Pd G3, 1-3 mol%), and the base (e.g., K₃PO₄, 2.0-3.0 equiv) to an oven-dried reaction vial equipped with a stir bar.
- Solvent Addition: Add the degassed solvent (e.g., dioxane/water 10:1, to achieve a concentration of 0.1-0.2 M with respect to the limiting reagent) via syringe.
- Reaction Execution: Seal the vial and place it in a preheated heating block or oil bath at the desired temperature (e.g., 100 °C). Stir vigorously for the required time (monitor by TLC, GC-MS, or LC-MS).
- Work-up: After the reaction is complete, cool the mixture to room temperature. Dilute with an organic solvent (e.g., ethyl acetate) and water. Separate the layers. Wash the organic layer

with brine, dry over anhydrous sodium sulfate, filter, and concentrate under reduced pressure.

- Purification: Purify the crude product by flash column chromatography.

Protocol for In-Situ Reaction Monitoring

For challenging reactions, real-time monitoring can provide invaluable insights.

- Thin-Layer Chromatography (TLC): A quick and easy way to qualitatively follow the consumption of starting materials and the formation of the product.[\[15\]](#)
- Gas Chromatography-Mass Spectrometry (GC-MS) / Liquid Chromatography-Mass Spectrometry (LC-MS): By taking small aliquots from the reaction at various time points, you can quantitatively determine the conversion and identify byproducts.
- In-situ NMR Spectroscopy: For reactions with suitable nuclei (e.g., ^{19}F), benchtop NMR can be used to monitor the reaction directly without the need for workup.[\[16\]](#) Automated reaction monitoring platforms can provide high-density temporal profiles for detailed mechanistic studies.[\[17\]](#)[\[18\]](#)

Visualizations

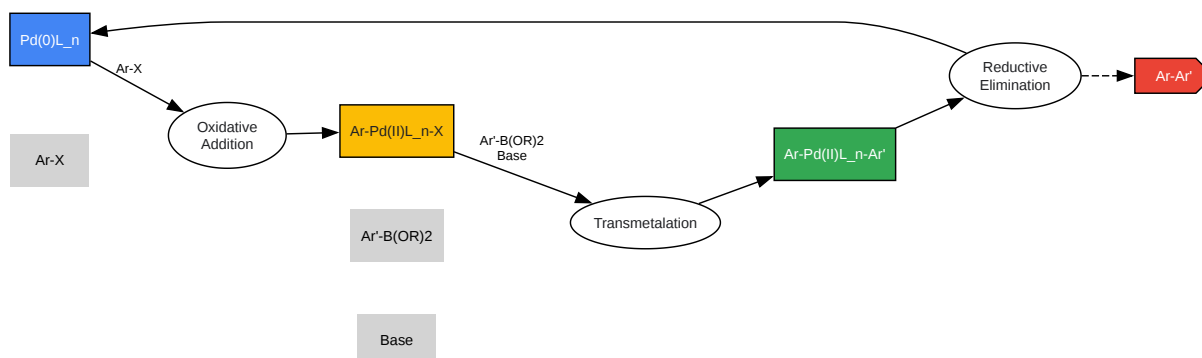

[Click to download full resolution via product page](#)

Caption: The catalytic cycle of the Suzuki-Miyaura cross-coupling reaction.

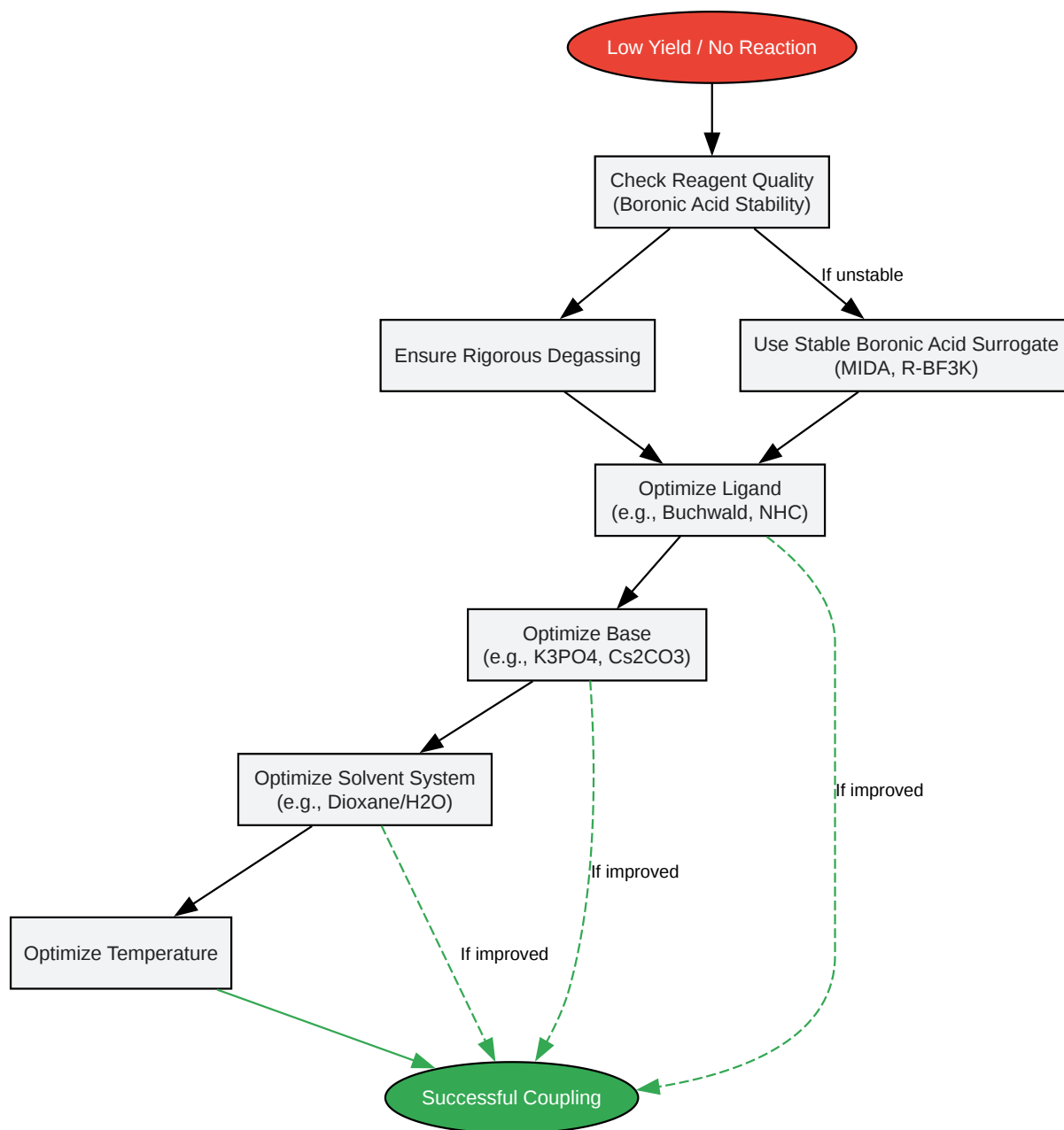

[Click to download full resolution via product page](#)

Caption: A systematic workflow for troubleshooting low-yielding reactions.

References

- Gillis, E. P., & Burke, M. D. (2009). Multistep Synthesis of Complex Boronic Acids from Simple MIDA Boronates. *Journal of the American Chemical Society*. Available at: [\[Link\]](#)
- Organic Chemistry Portal. (n.d.). Suzuki Coupling. Available at: [\[Link\]](#)
- Lipshutz, B. H., Petersen, T. B., & Abela, A. R. (2008). Room-Temperature Suzuki-Miyaura Couplings in Water Facilitated by Nonionic Amphiphiles. *Organic Letters*. Available at: [\[Link\]](#)
- Vapourtec. (2023). Liquid/liquid heterogeneous reaction monitoring: Insights into biphasic Suzuki-Miyaura cross-coupling. Available at: [\[Link\]](#)
- AZoM. (2018). Using Benchtop NMR Spectroscopy to Monitor Suzuki Coupling Reactions. Available at: [\[Link\]](#)
- Chemical Communications (RSC Publishing). (n.d.). Recent advances in the synthesis and reactivity of MIDA boronates. Available at: [\[Link\]](#)
- Lipshutz, B. H., Petersen, T. B., & Abela, A. R. (2008). Room-Temperature Suzuki-Miyaura Couplings in Water Facilitated by Nonionic Amphiphiles. *ResearchGate*. Available at: [\[Link\]](#)
- Kosaka, K., Ohta, Y., & Yokozawa, T. (2015). Influence of the boron moiety and water on suzuki-miyaura catalyst-transfer condensation polymerization. *Macromolecular Rapid Communications*. Available at: [\[Link\]](#)
- Advion. (n.d.). SUZUKI REACTION MONITORING. Available at: [\[Link\]](#)
- Hein, J. E. (2019). Mechanistic study of Suzuki-Miyaura cross-coupling reactions via real-time monitoring. University of British Columbia. Available at: [\[Link\]](#)
- Tang, W., & Zhang, X. (2014). Sterically Demanding Aryl-Alkyl Suzuki-Miyaura Coupling. *The Royal Society of Chemistry*. Available at: [\[Link\]](#)
- ChemistryViews. (2019). Water Is Key for Solid-State Suzuki-Miyaura Reactions. Available at: [\[Link\]](#)

- Sun, J., et al. (2018). STUDIES ON SUZUKI COUPLING REACTIONS OF LARGE STERICALLY HINDERED SUBSTRATES. ResearchGate. Available at: [\[Link\]](#)
- Lookchem. (n.d.). Potassium haloalkyltrifluoroborate salts: Synthesis, application, and reversible ligand replacement with MIDA. Available at: [\[Link\]](#)
- ACS Publications. (n.d.). Palladium-Catalyzed Suzuki Reactions in Water with No Added Ligand: Effects of Reaction Scale, Temperature, pH of Aqueous Phase, and Substrate Structure. Available at: [\[Link\]](#)
- Dalton Transactions (RSC Publishing). (n.d.). Steric and electronic effects of arsa-Buchwald ligands on Suzuki–Miyaura coupling reaction. Available at: [\[Link\]](#)
- ACS Publications. (n.d.). High-Activity Catalysts for Suzuki Coupling and Amination Reactions with Deactivated Aryl Chloride Substrates: Importance of the Palladium Source. Available at: [\[Link\]](#)
- ResearchGate. (2024). Suzuki-Miyaura and Buchwald-Hartwig Cross-Coupling Reactions Utilizing a Set of Complementary Imidazopyridine Monophosphine Ligands. Available at: [\[Link\]](#)
- Reddit. (2016). Why is the Suzuki-Miyaura coupling reaction steric sensitive?. Available at: [\[Link\]](#)
- Organic Syntheses. (2024). Palladium-catalyzed Buchwald-Hartwig Amination and Suzuki-Miyaura Cross-coupling Reaction of Aryl Mesylates. Available at: [\[Link\]](#)
- NIH. (n.d.). Application of Suzuki-Miyaura and Buchwald-Hartwig Cross-coupling Reactions to the Preparation of Substituted 1,2,4-Benzotriazine 1-Oxides Related to the Antitumor Agent Tirapazamine. Available at: [\[Link\]](#)

Need Custom Synthesis?

BenchChem offers custom synthesis for rare earth carbides and specific isotopic labeling.

Email: info@benchchem.com or [Request Quote Online](#).

Sources

- [1. reddit.com \[reddit.com\]](#)
- [2. Steric and electronic effects of arsa-Buchwald ligands on Suzuki–Miyaura coupling reaction - Dalton Transactions \(RSC Publishing\) \[pubs.rsc.org\]](#)
- [3. Suzuki Coupling \[organic-chemistry.org\]](#)
- [4. sigmaaldrich.com \[sigmaaldrich.com\]](#)
- [5. Multistep Synthesis of Complex Boronic Acids from Simple MIDA Boronates - PMC \[pmc.ncbi.nlm.nih.gov\]](#)
- [6. Recent advances in the synthesis and reactivity of MIDA boronates - Chemical Communications \(RSC Publishing\) \[pubs.rsc.org\]](#)
- [7. sigmaaldrich.com \[sigmaaldrich.com\]](#)
- [8. merckmillipore.com \[merckmillipore.com\]](#)
- [9. researchgate.net \[researchgate.net\]](#)
- [10. orgsyn.org \[orgsyn.org\]](#)
- [11. Application of Suzuki-Miyaura and Buchwald-Hartwig Cross-coupling Reactions to the Preparation of Substituted 1,2,4-Benzotriazine 1-Oxides Related to the Antitumor Agent Tirapazamine - PMC \[pmc.ncbi.nlm.nih.gov\]](#)
- [12. pubs.rsc.org \[pubs.rsc.org\]](#)
- [13. Influence of the boron moiety and water on suzuki-miyaura catalyst-transfer condensation polymerization - PubMed \[pubmed.ncbi.nlm.nih.gov\]](#)
- [14. Water Is Key for Solid-State Suzuki-Miyaura Reactions - ChemistryViews \[chemistryviews.org\]](#)
- [15. shoko-sc.co.jp \[shoko-sc.co.jp\]](#)
- [16. azom.com \[azom.com\]](#)
- [17. vapourtec.com \[vapourtec.com\]](#)
- [18. Mechanistic study of Suzuki-Miyaura cross-coupling reactions via real-time monitoring - UBC Library Open Collections \[open.library.ubc.ca\]](#)
- To cite this document: BenchChem. [Technical Support Center: Navigating the Challenges of Sterically Hindered Boronic Acids]. BenchChem, [2026]. [Online PDF]. Available at: [<https://www.benchchem.com/product/b6327070/docs#technical-support-center-navigating-the-challenges-of-sterically-hindered-boronic-acids>]

Disclaimer & Data Validity:

The information provided in this document is for Research Use Only (RUO) and is strictly not intended for diagnostic or therapeutic procedures. While BenchChem strives to provide accurate protocols, we make no warranties, express or implied, regarding the fitness of this product for every specific experimental setup.

Technical Support: The protocols provided are for reference purposes. Unsure if this reagent suits your experiment?

Need Industrial/Bulk Grade? [Request Custom Synthesis Quote](#)

BenchChem

Our mission is to be the trusted global source of essential and advanced chemicals, empowering scientists and researchers to drive progress in science and industry.

Contact

Address: 3281 E Guasti Rd
Ontario, CA 91761, United States
Phone: (601) 213-4426
Email: info@benchchem.com

[Contact our Ph.D. Support Team for a compatibility check](#)