

Application Note: Experimental Protocols for the Synthesis of Pyrazole Carboxylic Acids

Author: BenchChem Technical Support Team. **Date:** May 2026

Compound of Interest

Compound Name: *5-(furan-2-yl)-1H-pyrazole-4-carboxylic acid*

CAS No.: *1152543-82-2*

Cat. No.: *B1437934*

[Get Quote](#)

Introduction: The Central Role of Pyrazole Carboxylic Acids in Modern Chemistry

Pyrazole carboxylic acids represent a cornerstone scaffold in contemporary drug discovery and agrochemical development. Their rigid, planar structure and unique arrangement of hydrogen bond donors and acceptors allow them to serve as versatile bioisosteres for other functional groups, leading to potent and selective interactions with biological targets. Blockbuster drugs such as the COX-2 inhibitor Celecoxib and various fungicides like Bixafen and Fluxapyroxad feature this critical chemical motif, underscoring its importance.^{[1][2]}

However, the synthesis of specifically substituted pyrazole carboxylic acids is not without its challenges. Controlling regioselectivity during the core ring-forming reaction is paramount, as different isomers can possess vastly different biological activities. Furthermore, the synthetic routes must tolerate a wide range of other functional groups necessary for modulating the molecule's pharmacokinetic and pharmacodynamic properties.

This application note provides an in-depth guide to the most reliable and field-proven experimental protocols for synthesizing pyrazole carboxylic acids. Moving beyond a simple recitation of steps, this document elucidates the underlying chemical principles and strategic considerations behind each protocol, empowering researchers to not only replicate these methods but also to adapt and troubleshoot them for their specific molecular targets. We will explore three primary strategies: the classic Knorr condensation, synthesis via formyl-acetate equivalents, and modern 1,3-dipolar cycloaddition reactions.

Core Synthetic Strategy 1: Knorr Pyrazole Synthesis and Related Condensations

The Knorr synthesis, first reported in 1883, remains one of the most robust and widely used methods for constructing the pyrazole core.^[1] The fundamental principle involves the condensation of a hydrazine derivative with a 1,3-dicarbonyl compound. To yield a pyrazole carboxylic acid, one of the carbonyl groups is typically part of a β -ketoester or a related precursor, which provides the latent carboxylic acid functionality.

Causality and Mechanistic Insight: The reaction proceeds via initial nucleophilic attack of a hydrazine nitrogen onto one of the carbonyl carbons, forming a hydrazone intermediate. Subsequent intramolecular condensation (cyclization) via attack of the second nitrogen atom onto the remaining carbonyl group, followed by dehydration, yields the aromatic pyrazole ring. The primary challenge in this synthesis is controlling which nitrogen of an unsymmetrical hydrazine attacks which carbonyl group, and which carbonyl is attacked first, directly influencing the final substitution pattern (regioselectivity).

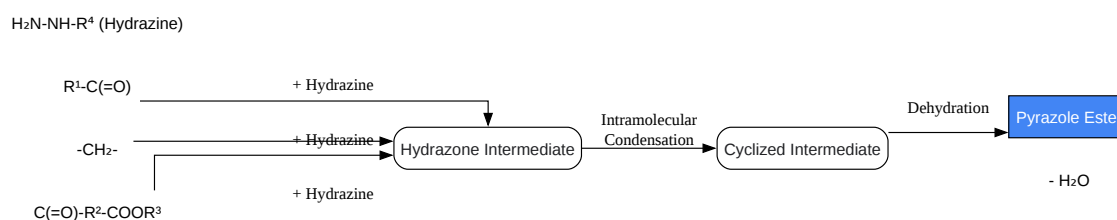

Figure 1: Knorr Pyrazole Synthesis Mechanism

[Click to download full resolution via product page](#)

Caption: Figure 1: Knorr Pyrazole Synthesis Mechanism.

Protocol 1.1: Synthesis of Ethyl 5-methyl-1H-pyrazole-3-carboxylate and Subsequent Hydrolysis

This protocol demonstrates a classic approach starting from a readily available β -ketoester, ethyl acetoacetate, to produce a pyrazole-3-carboxylic acid. The initial product is an ester, which is subsequently hydrolyzed.

Step-by-Step Methodology:

- **Reaction Setup:** To a 250 mL round-bottom flask equipped with a magnetic stirrer and a reflux condenser, add ethyl acetoacetate (13.0 g, 0.1 mol) and ethanol (100 mL).
- **Hydrazine Addition:** While stirring at room temperature, slowly add hydrazine hydrate (5.0 g, 0.1 mol) dropwise to the solution. **Expert Insight:** The addition should be controlled as the initial reaction can be exothermic. Using hydrazine hydrate is common, but anhydrous hydrazine in a suitable solvent can also be used for substrates sensitive to water.

- **Cyclization:** After the addition is complete, heat the reaction mixture to reflux (approximately 78°C for ethanol) and maintain for 3-4 hours. Monitor the reaction progress using Thin Layer Chromatography (TLC).
- **Workup and Isolation (Ester):** Cool the reaction mixture to room temperature and then place it in an ice bath for 30 minutes to precipitate the product. Collect the solid product by vacuum filtration, wash with a small amount of cold ethanol, and dry under vacuum. The product is ethyl 5-methyl-1H-pyrazole-3-carboxylate.
- **Hydrolysis to Carboxylic Acid:** Transfer the isolated pyrazole ester (e.g., 0.08 mol) to a flask containing a solution of sodium hydroxide (8.0 g, 0.2 mol) in water (100 mL).
- **Saponification:** Heat the mixture to reflux for 2 hours or until the reaction is complete (TLC monitoring, showing disappearance of the ester spot). **Trustworthiness Check:** Complete hydrolysis is crucial. The ester is significantly more soluble in organic solvents than the carboxylate salt, providing a clear separation in the subsequent step.
- **Acidification and Isolation (Acid):** Cool the solution in an ice bath and carefully acidify with concentrated hydrochloric acid until the pH is approximately 2-3. A white precipitate of 5-methyl-1H-pyrazole-3-carboxylic acid will form.
- **Final Purification:** Collect the solid by vacuum filtration, wash thoroughly with cold water to remove inorganic salts, and dry under vacuum to yield the final product.

Protocol 1.2: One-Pot Synthesis of 4-Substituted 1,5-Diaryl-1H-pyrazole-3-carboxylic Acids

This advanced protocol utilizes a one-pot sequence involving a sterically hindered Claisen condensation, a Knorr reaction, and hydrolysis to afford highly substituted pyrazole carboxylic acids.^[3]

Step-by-Step Methodology:

- **Claisen Condensation:** In a flame-dried, three-neck flask under a nitrogen atmosphere, dissolve an appropriate acetophenone derivative (10 mmol) and a substituted diethyl oxalate (12 mmol) in anhydrous THF (50 mL). Cool the solution to 0°C.

- **Base Addition:** Add a strong base such as sodium methoxide (MeONa, 25 mmol) portion-wise, maintaining the temperature below 5°C. Stir at this temperature for 1 hour, then allow the mixture to warm to room temperature and stir for an additional 4-6 hours to form the 1,3-diketoester intermediate.
- **Knorr Cyclization:** Add the desired arylhydrazine hydrochloride (11 mmol) directly to the reaction mixture, followed by glacial acetic acid (5 mL) to catalyze the cyclization.
- **Heating and Hydrolysis:** Heat the mixture to reflux (approx. 66°C for THF) for 8-12 hours. The cyclization and subsequent hydrolysis of the ethyl ester occur in this step.
- **Workup and Isolation:** After cooling, pour the reaction mixture into ice-cold water (200 mL) and acidify to pH 2 with concentrated HCl. The resulting precipitate is collected by filtration.
- **Purification:** The crude solid is purified by recrystallization from an appropriate solvent system (e.g., ethanol/water) to yield the pure 1,5-diaryl-4-substituted-pyrazole-3-carboxylic acid.

Core Synthetic Strategy 2: Synthesis via Formyl-Acetate Equivalents for Pyrazole-4-Carboxylic Acids

To synthesize pyrazole-4-carboxylic acids, a different set of starting materials is required. The key is to use a three-carbon building block where the central carbon will become C4 of the pyrazole ring and already bears the carboxylate (or precursor) group. A common and effective starting material is diethyl ethoxymethylenemalonate (DEEM).

Causality and Mechanistic Insight: DEEM reacts with hydrazine in a sequence of Michael addition followed by cyclization and elimination of ethanol and water. The ethoxymethylene group acts as a masked aldehyde, and its position beta to two ester groups makes it highly electrophilic. The regioselectivity is generally excellent because the initial attack of the hydrazine occurs at the electrophilic β -carbon of the double bond.

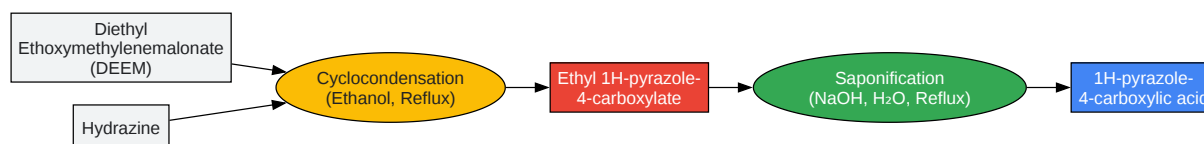

Figure 2: Workflow for Pyrazole-4-Carboxylic Acid Synthesis

[Click to download full resolution via product page](#)

Caption: Figure 2: Workflow for Pyrazole-4-Carboxylic Acid Synthesis.

Protocol 2.1: Synthesis of Ethyl 1H-pyrazole-4-carboxylate and Hydrolysis

This robust protocol provides straightforward access to the parent pyrazole-4-carboxylic acid, a valuable building block.[4]

Step-by-Step Methodology:

- **Reaction Setup:** In a 500 mL flask equipped with a reflux condenser and magnetic stirrer, combine diethyl ethoxymethylenemalonate (DEEM) (43.2 g, 0.2 mol) and ethanol (200 mL).
- **Hydrazine Addition:** At room temperature, add hydrazine hydrate (10.0 g, 0.2 mol) dropwise with stirring. An exothermic reaction will occur, and the internal temperature should be monitored.
- **Reflux:** After the addition is complete, heat the mixture to reflux for 4 hours. The reaction is typically complete at this point.
- **Isolation of Ester:** Remove the ethanol under reduced pressure using a rotary evaporator. The resulting residue is the crude ethyl 1H-pyrazole-4-carboxylate, which often solidifies upon cooling and can be used directly in the next step or purified by recrystallization from ethyl acetate/hexanes.

- Saponification: Dissolve the crude ester in a solution of potassium hydroxide (22.4 g, 0.4 mol) in 200 mL of water.
- Heating: Heat the mixture at 90-100°C for 3-5 hours until the hydrolysis is complete. Expert Insight: Using potassium hydroxide can sometimes lead to a more soluble potassium salt, which may aid in reaction completion compared to sodium hydroxide.
- Acidification: Cool the reaction mixture to 0-5°C in an ice bath. Very slowly and with vigorous stirring, add concentrated hydrochloric acid to adjust the pH to ~2.
- Product Isolation: The white solid of 1H-pyrazole-4-carboxylic acid will precipitate. Allow the slurry to stir in the cold for 30 minutes to ensure complete precipitation. Collect the product by vacuum filtration, wash with ice-cold water, and dry thoroughly.

Core Synthetic Strategy 3: 1,3-Dipolar Cycloaddition

A more modern and highly versatile approach to pyrazole synthesis is the [3+2] cycloaddition reaction between a diazo compound (the 3-atom component) and an alkyne (the 2-atom component).[3] To synthesize pyrazole carboxylic acids, either the diazo compound or the alkyne must possess a carboxylate or ester group. A particularly safe and convenient variation generates the reactive diazo compound in situ from a stable precursor like a tosylhydrazone.[5]

Causality and Mechanistic Insight: A base deprotonates the tosylhydrazone, leading to the elimination of p-toluenesulfonic acid and the formation of a transient diazo species. This highly reactive 1,3-dipole then rapidly undergoes a concerted cycloaddition with an alkyne. The regioselectivity is governed by the electronic properties of both the diazo compound and the alkyne.

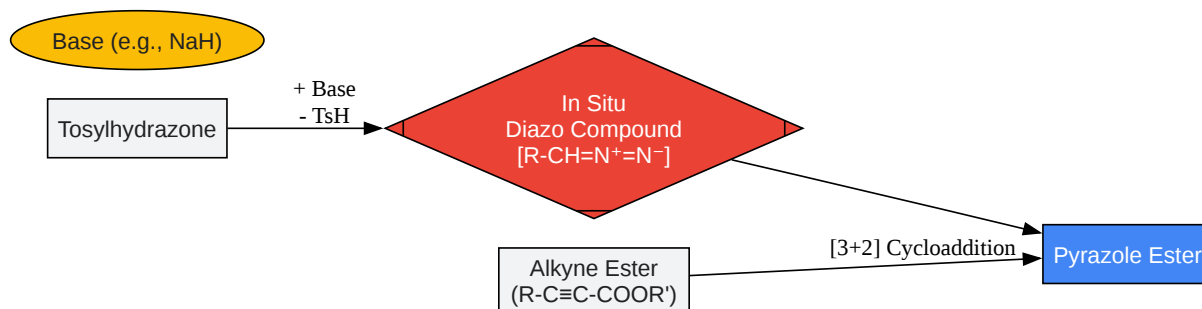

Figure 3: In Situ Diazo Generation and Cycloaddition

[Click to download full resolution via product page](#)

Caption: Figure 3: In Situ Diazo Generation and Cycloaddition.

Protocol 3.1: One-Pot Synthesis of Ethyl 5-phenyl-1H-pyrazole-3-carboxylate

This protocol uses the tosylhydrazone of benzaldehyde and ethyl propiolate to generate a pyrazole-3-carboxylate.

Step-by-Step Methodology:

- **Reaction Setup:** To a flame-dried 100 mL Schlenk flask under nitrogen, add benzaldehyde tosylhydrazone (2.74 g, 10 mmol) and anhydrous acetonitrile (40 mL).
- **Base Addition:** Cool the suspension to 0°C and add sodium hydride (60% dispersion in mineral oil, 0.48 g, 12 mmol) portion-wise. **Safety and Expertise:** NaH is highly reactive with water. Ensure all glassware is dry and the reaction is under an inert atmosphere. The reaction will evolve hydrogen gas.
- **Diazo Formation:** Stir the mixture at 0°C for 30 minutes, then allow it to warm to room temperature and stir for an additional 1 hour. The formation of the orange-red color of the diazo compound may be visible.

- Alkyne Addition: Add ethyl propiolate (1.08 g, 11 mmol) to the reaction mixture via syringe.
- Cycloaddition Reaction: Heat the reaction mixture to 60°C and stir for 12-18 hours. Monitor by TLC for the consumption of the tosylhydrazone.
- Quenching and Workup: After cooling, carefully quench the reaction by the slow addition of saturated aqueous ammonium chloride solution (20 mL). Transfer the mixture to a separatory funnel and extract with ethyl acetate (3 x 40 mL).
- Purification: Combine the organic layers, wash with brine, dry over anhydrous sodium sulfate, and concentrate under reduced pressure. The crude residue is purified by flash column chromatography on silica gel (eluting with a hexane/ethyl acetate gradient) to afford the pure ethyl 5-phenyl-1H-pyrazole-3-carboxylate.
- Hydrolysis: The resulting ester can be hydrolyzed to the corresponding carboxylic acid using the procedure described in Protocol 1.1 (Steps 5-8).

Data Summary and Characterization

Validation of the synthesized pyrazole carboxylic acid is critical. A combination of spectroscopic methods and physical characterization confirms the identity and purity of the final product.

Table 1: Representative Characterization Data for 5-Methyl-1H-pyrazole-3-carboxylic Acid

Parameter	Expected Value/Observation
Appearance	White to off-white crystalline solid
Melting Point	~225-228 °C (decomposes)
¹ H NMR (DMSO-d ₆)	δ ~13.0 (br s, 2H, COOH + NH), 6.3 (s, 1H, pyrazole C4-H), 2.2 (s, 3H, CH ₃)
¹³ C NMR (DMSO-d ₆)	δ ~163 (C=O), 148 (pyrazole C5), 140 (pyrazole C3), 105 (pyrazole C4), 11 (CH ₃)
IR (KBr, cm ⁻¹)	3100-2500 (broad, O-H), 1700 (C=O), 1580 (C=N)
Mass Spec (ESI-)	[M-H] ⁻ calculated for C ₅ H ₅ N ₂ O ₂ ⁻ : 125.04; found: 125.0

References

- Organic Chemistry Portal. (n.d.). Pyrazole synthesis. Retrieved January 26, 2026, from [[Link](#)]
- Fustero, S., Sánchez-Roselló, M., & Barrio, P. (2011). Recent Advances in the Synthesis of Pyrazoles. A Review. *Current Organic Chemistry*, 15(21), 3845-3885.
- Yadav, G., & Singh, R. (2023). Recent Advances in the Synthesis of Pyrazole Derivatives: A Review. *Molecules*, 28(18), 6529.
- Bildirici, I., & Cetin, A. (2019). Synthesis and Some Reactions of Pyrazole-3-carboxylic acid Having Trifluoromethyl Unit. *Düzce Üniversitesi Bilim ve Teknoloji Dergisi*, 7(3), 1334-1346.
- Google Patents. (2020). CN111138289B - Compound and process for synthesizing 5-acetyl-1H-pyrazole-3-carboxylic acid by using same.
- Akrouf, A., et al. (2020). Synthesis and Pharmacological Activities of Pyrazole Derivatives: A Review. *Molecules*, 25(17), 3948.
- IntechOpen. (2021). Pyrazole Carboxylic Acid and Derivatives: Synthesis and Biological Applications. Retrieved January 26, 2026, from [[Link](#)]
- Quick Company. (n.d.). Process For The Manufacture Of Pyrazole Carboxylic Derivatives And Precursors Thereof. Retrieved January 26, 2026, from [[Link](#)]

- Google Patents. (2012). WO2012025469A1 - Improved process for the preparation of esters of 1-h-pyrazole-4-carboxylic acids.
- Kim, J. S., et al. (2019). Pyrazoles: 'one-pot' synthesis from arenes and carboxylic acids. *Organic & Biomolecular Chemistry*, 17(3), 577-584.
- American Chemical Society. (2024). Azo Pyrazole Carboxylic Derivatives for Potential Energetic Materials. Retrieved January 26, 2026, from [\[Link\]](#)
- ResearchGate. (n.d.). Synthesis of pyrazole carboxylic acid intermediate 5. Retrieved January 26, 2026, from [\[Link\]](#)
- Padwa, A., et al. (2005). A Novel One-Pot Method for the Preparation of Pyrazoles by 1,3-Dipolar Cycloadditions of Diazo Compounds Generated in Situ. *The Journal of Organic Chemistry*, 70(14), 5472-5479.
- Lindner, S., et al. (2023). Synthesis and structure–activity relationships of pyrazole-based inhibitors of meprin α and β . *European Journal of Medicinal Chemistry*, 246, 114960.

Need Custom Synthesis?

BenchChem offers custom synthesis for rare earth carbides and specific isotopic labeling.

Email: info@benchchem.com or [Request Quote Online](#).

Sources

- 1. BJOC - Multicomponent syntheses of pyrazoles via (3 + 2)-cyclocondensation and (3 + 2)-cycloaddition key steps [beilstein-journals.org]
- 2. Process For The Manufacture Of Pyrazole Carboxylic Derivatives And [quickcompany.in]
- 3. Pyrazole synthesis [organic-chemistry.org]
- 4. WO2012025469A1 - Improved process for the preparation of esters of 1-h-pyrazole-4-carboxylic acids - Google Patents [patents.google.com]
- 5. pubs.acs.org [pubs.acs.org]
- To cite this document: BenchChem. [Application Note: Experimental Protocols for the Synthesis of Pyrazole Carboxylic Acids]. BenchChem, [2026]. [Online PDF]. Available at: [<https://www.benchchem.com/product/b1437934/docs#application-note-experimental-protocols-for-the-synthesis-of-pyrazole-carboxylic-acids>]

Disclaimer & Data Validity:

The information provided in this document is for Research Use Only (RUO) and is strictly not intended for diagnostic or therapeutic procedures. While BenchChem strives to provide accurate protocols, we make no warranties, express or implied, regarding the fitness of this product for every specific experimental setup.

Technical Support: The protocols provided are for reference purposes. Unsure if this reagent suits your experiment?

Need Industrial/Bulk Grade? [Request Custom Synthesis Quote](#)

BenchChem

Our mission is to be the trusted global source of essential and advanced chemicals, empowering scientists and researchers to drive progress in science and industry.

Contact

Address: 3281 E Guasti Rd
Ontario, CA 91761, United States
Phone: (601) 213-4426
Email: info@benchchem.com

[Contact our Ph.D. Support Team for a compatibility check](#)