

Thermodynamic properties of binary Mo-Ti systems

Author: BenchChem Technical Support Team. **Date:** April 2026

Compound of Interest

Compound Name: Molybdenum;titanium

CAS No.: 91651-22-8

Cat. No.: B14365915

[Get Quote](#)

An In-Depth Technical Guide to the Thermodynamic Properties of Binary Mo-Ti Systems

For Researchers, Scientists, and Drug Development Professionals

Introduction

The binary Molybdenum-Titanium (Mo-Ti) system is of significant interest across various scientific and industrial fields, including aerospace, high-temperature applications, and notably, the development of biomedical implants.[1][2] Molybdenum is a potent beta-stabilizing element for titanium alloys, allowing for the retention of the body-centered cubic (BCC) β -phase at room temperature.[2][3][4] This is crucial for producing alloys with a low elastic modulus, which is beneficial for biomedical applications as it can mitigate stress shielding effects when implanted in the human body.[1][2] A thorough understanding of the thermodynamic properties of the Mo-Ti system is paramount for the design and processing of these advanced materials. This guide provides a comprehensive overview of the thermodynamic landscape of binary Mo-Ti alloys, focusing on phase stability, thermodynamic data, and the experimental and theoretical methodologies used for their determination.

The Mo-Ti Phase Diagram: A Complex Landscape

The Mo-Ti phase diagram has been a subject of considerable research, leading to some conflicting descriptions of its features, particularly concerning the stability of the β -phase at lower temperatures.^[1] The equilibrium solid phases are the BCC (β -Ti, Mo) solid solution, where Ti and Mo are fully miscible at high temperatures, and the hexagonal close-packed (HCP) α -Ti solid solution with limited Mo solubility.

Two primary interpretations of the β -phase stability exist:

- A monotonic decrease in the β -transus temperature with increasing molybdenum content.^[1]
- A more complex solvus featuring a monotectoid phase separation and a miscibility gap between two distinct β phases.^[1]

Recent computational studies using ab-initio calculations have predicted a more intricate phase diagram at temperatures below 900°C, suggesting the existence of stable stoichiometric compounds that have not yet been experimentally observed.^[1] These computational findings indicate that the transition to the β -phase solid solution at lower temperatures might be more complex than previously thought, a discrepancy attributed to the slow kinetics and long equilibration times required for experimental verification.^[1]

Below is a DOT language representation of a simplified, commonly accepted version of the Mo-Ti phase diagram, highlighting the key phases.

Simplified Mo-Ti Phase Diagram

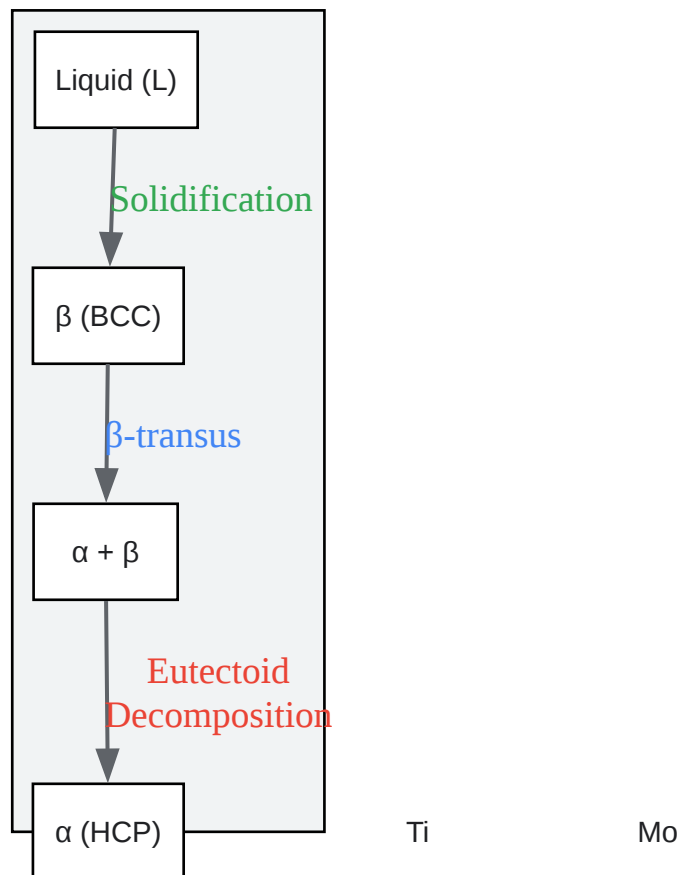

[Click to download full resolution via product page](#)

A simplified representation of the Mo-Ti phase diagram.

Thermodynamic Data of the Mo-Ti System

The thermodynamic properties of the Mo-Ti system, such as enthalpy of mixing, Gibbs free energy of formation, and the activity of the constituent elements, are crucial for predicting phase stability and driving forces for phase transformations. While extensive experimental data in tabulated form is scarce in the literature, computational methods like CALPHAD (CALculation of PHase Diagrams) and ab-initio calculations provide valuable insights.

Enthalpy of Mixing

The enthalpy of mixing (ΔH_{mix}) is a measure of the heat absorbed or released when two elements are mixed to form an alloy. A negative ΔH_{mix} indicates an exothermic reaction, suggesting a tendency towards ordering or compound formation, while a positive value

signifies an endothermic reaction, indicating a tendency towards phase separation. For the Mo-Ti system, both experimental and computational studies have been conducted.

Table 1: Calculated Enthalpy of Mixing for Equiatomic Mo-Ti Alloy

Method	Enthalpy of Mixing (kJ/mol)	Reference
Density Functional Theory (DFT)	Varies with composition	[5]
Miedema's Model	Varies with composition	[5]

Note: Specific values for equiatomic composition were not explicitly tabulated in the search results but are generally negative, indicating a favorable interaction between Mo and Ti atoms.

Gibbs Free Energy of Formation

The Gibbs free energy of formation (ΔG_f) determines the thermodynamic stability of a phase at a given temperature and composition. A more negative ΔG_f indicates a more stable phase. Gibbs free energy curves as a function of composition are often used to determine the equilibrium phases.

Table 2: Calculated Thermodynamic Parameters from CALPHAD Assessments

Parameter	Value/Expression	Reference
Gibbs Energy of Liquid Phase	Redlich-Kister Polynomial	[6][7]
Gibbs Energy of BCC (β) Phase	Redlich-Kister Polynomial	[6][7]
Gibbs Energy of HCP (α) Phase	Redlich-Kister Polynomial	[6][7]

Note: The specific coefficients for the Redlich-Kister polynomials are found in thermodynamic databases and detailed publications on CALPHAD modeling of the Mo-Ti system.[6][7]

Below is a graphical representation of the relationship between Gibbs free energy and phase stability.

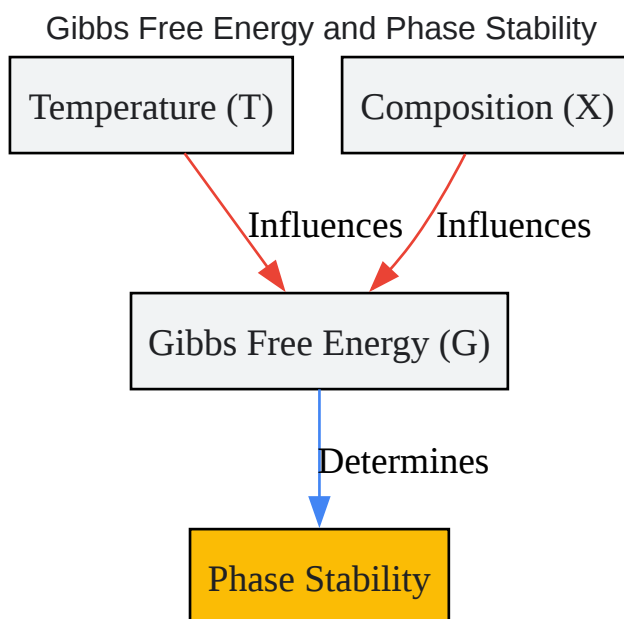

[Click to download full resolution via product page](#)

Factors influencing Gibbs free energy and phase stability.

Experimental Protocols for Thermodynamic Characterization

The experimental determination of thermodynamic properties for refractory metal alloys like Mo-Ti presents significant challenges due to their high melting points and reactivity at elevated temperatures.

Sample Preparation for Thermodynamic Analysis

Proper sample preparation is critical to obtain accurate and reproducible results. For Mo-Ti alloys, this typically involves:

- Alloy Synthesis: High-purity molybdenum and titanium are weighed to the desired composition and arc-melted in an inert atmosphere (e.g., argon) to create a homogeneous ingot.[3] Multiple melting and flipping steps are often necessary to ensure homogeneity.

- **Homogenization:** The as-cast ingots are sealed in an inert atmosphere (e.g., in a quartz tube backfilled with argon) and annealed at a high temperature (e.g., 1000-1200 °C) for an extended period (e.g., 24-72 hours) to eliminate compositional segregation.
- **Specimen Machining:** The homogenized ingot is then machined into the desired shape and size for the specific thermal analysis technique.

Differential Thermal Analysis (DTA) / Differential Scanning Calorimetry (DSC)

DTA and DSC are powerful techniques for determining phase transition temperatures.

Generalized Protocol:

- **Sample and Reference Preparation:** A small, accurately weighed sample of the Mo-Ti alloy (typically 10-50 mg) is placed in a crucible (e.g., alumina, zirconia, or tungsten). An empty crucible or an inert reference material (e.g., alumina) is used for the reference pan.
- **Atmosphere Control:** The DTA/DSC chamber is purged with a high-purity inert gas (e.g., argon) to prevent oxidation of the sample at high temperatures.
- **Heating and Cooling Program:** The sample and reference are heated and cooled at a controlled rate (e.g., 5-20 °C/min) over the temperature range of interest.
- **Data Analysis:** The difference in temperature (DTA) or heat flow (DSC) between the sample and the reference is recorded as a function of temperature. Endothermic or exothermic peaks in the resulting thermogram indicate phase transitions. The onset temperature of a peak is typically taken as the transition temperature.

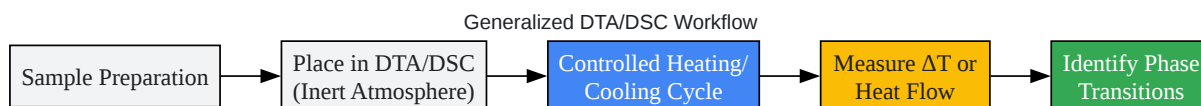

[Click to download full resolution via product page](#)

A generalized workflow for DTA/DSC analysis.

High-Temperature Calorimetry

High-temperature calorimeters, such as drop calorimeters, are used to measure the enthalpy of mixing and heat capacity of alloys at elevated temperatures.

Generalized Drop Calorimetry Protocol:

- **Calorimeter Setup:** A high-temperature calorimeter containing a solvent bath (for solution calorimetry) or an empty crucible (for heat content measurement) is heated to and stabilized at the desired experimental temperature.
- **Sample Drop:** A precisely weighed sample of the Mo-Ti alloy, initially at a known temperature (often room temperature), is dropped into the hot calorimeter.
- **Heat Flow Measurement:** The heat absorbed or released by the sample as it equilibrates with the calorimeter's temperature is measured.
- **Enthalpy Calculation:** The enthalpy of mixing or heat content is calculated from the measured heat flow and the known masses and heat capacities of the sample and calorimeter components.

Theoretical Approaches to Thermodynamic Modeling

Given the experimental difficulties, theoretical and computational methods play a crucial role in understanding the thermodynamics of the Mo-Ti system.

CALPHAD (CALculation of PHase Diagrams)

The CALPHAD method is a powerful computational tool used to model the thermodynamic properties of multicomponent systems.^{[6][7][8]} It involves developing thermodynamic models for the Gibbs free energy of each phase in the system. These models contain adjustable parameters that are optimized to fit available experimental data, such as phase diagram information and thermochemical data.^[8] Once a self-consistent thermodynamic database is established, it can be used to calculate phase diagrams and other thermodynamic properties for a wide range of compositions and temperatures.^{[6][7]}

Ab-initio Calculations

Ab-initio (or first-principles) calculations, based on density functional theory (DFT), are used to compute the total energy of different crystal structures and compositions from fundamental quantum mechanical principles, without any experimental input.[1][3] These calculations can provide valuable data on the enthalpy of formation of stable and metastable phases, which can then be used as input for CALPHAD models, especially in systems where experimental data is scarce.[1] Recent ab-initio studies on the Mo-Ti system have been instrumental in predicting the existence of previously unknown low-temperature phases.[1]

Conclusion

The thermodynamic properties of the binary Mo-Ti system are complex and of great importance for the development of advanced materials, particularly for biomedical applications. While experimental determination of these properties at high temperatures is challenging, a combination of experimental techniques like DTA/DSC and high-temperature calorimetry, along with computational methods such as CALPHAD and ab-initio calculations, has provided a progressively clearer picture of the phase stability and thermodynamic parameters of this system. Continued research, particularly focused on obtaining more extensive experimental data, will be crucial for further refining the thermodynamic databases and enabling the knowledge-based design of novel Mo-Ti alloys with tailored properties for specific applications.

Need Custom Synthesis?

BenchChem offers custom synthesis for rare earth carbides and specific isotopic labeling.

Email: info@benchchem.com or [Request Quote Online](#).

References

- [1. arxiv.org \[arxiv.org\]](#)
- [2. researchgate.net \[researchgate.net\]](#)
- [3. dunand.northwestern.edu \[dunand.northwestern.edu\]](#)
- [4. mdpi.com \[mdpi.com\]](#)
- [5. researchgate.net \[researchgate.net\]](#)

- [6. inldigitallibrary.inl.gov \[inldigitallibrary.inl.gov\]](https://inldigitallibrary.inl.gov)
- [7. jmmab.com \[jmmab.com\]](https://jmmab.com)
- [8. THE CALPHAD METHOD AND ITS ROLE IN MATERIAL AND PROCESS DEVELOPMENT - PMC \[pmc.ncbi.nlm.nih.gov\]](https://pubmed.ncbi.nlm.nih.gov/31111111/)
- To cite this document: BenchChem. [Thermodynamic properties of binary Mo-Ti systems]. BenchChem, [2026]. [Online PDF]. Available at: [\[https://www.benchchem.com/product/b14365915/docs#thermodynamic-properties-of-binary-mo-ti-systems\]](https://www.benchchem.com/product/b14365915/docs#thermodynamic-properties-of-binary-mo-ti-systems)

Disclaimer & Data Validity:

The information provided in this document is for Research Use Only (RUO) and is strictly not intended for diagnostic or therapeutic procedures. While BenchChem strives to provide accurate protocols, we make no warranties, express or implied, regarding the fitness of this product for every specific experimental setup.

Technical Support: The protocols provided are for reference purposes. Unsure if this reagent suits your experiment?

Need Industrial/Bulk Grade? [Request Custom Synthesis Quote](#)

BenchChem

Our mission is to be the trusted global source of essential and advanced chemicals, empowering scientists and researchers to drive progress in science and industry.

Contact

Address: 3281 E Guasti Rd
Ontario, CA 91761, United States
Phone: (601) 213-4426
Email: info@benchchem.com

[Contact our Ph.D. Support Team for a compatibility check](#)

