

# Bioconjugation techniques involving 3-Chloro-5-ethynylisoquinoline

**Author:** BenchChem Technical Support Team. **Date:** May 2026

## Compound of Interest

Compound Name: 3-Chloro-5-ethynylisoquinoline

CAS No.: 1822784-14-4

Cat. No.: B1436038

[Get Quote](#)

Application Note: Bioconjugation Techniques Involving **3-Chloro-5-ethynylisoquinoline**

## Executive Summary

**3-Chloro-5-ethynylisoquinoline** represents a specialized class of "clickable" pharmacophores. Its structural duality—featuring a chemically stable isoquinoline core with a reactive ethynyl handle—makes it an ideal scaffold for Activity-Based Protein Profiling (ABPP) and fragment-based drug discovery (FBDD).

While the 3-chloro substituent often serves as a medicinal chemistry handle (for structure-activity relationship modulation or hydrophobic binding), the 5-ethynyl group is the primary site for bioconjugation via Copper-Catalyzed Azide-Alkyne Cycloaddition (CuAAC). This guide provides validated protocols for conjugating this scaffold to azide-functionalized reporters (fluorophores, biotin) and biological macromolecules, emphasizing solubility management and catalyst optimization.

## Chemical Profile & Reactivity

Before initiating conjugation, researchers must understand the functional group interplay of the molecule.

Feature	Chemical Nature	Bioconjugation Role	Reactivity Considerations
5-Ethynyl Group	Terminal Alkyne (ngcontent-ng-c2307461527="" _ngghost-ng-c2764567632="" class="inline ng-star-inserted"> )	Primary Conjugation Site	Reacts with Azides ( ) via CuAAC to form stable 1,2,3-triazoles.
3-Chloro Group	Aryl Chloride	Structural/Binding Element	Generally inert under aqueous bioconjugation conditions. Serves as a lipophilic handle or site for Pd-catalyzed coupling during synthesis.
Isoquinoline Core	Heterocyclic Aromatic	Pharmacophore	Hydrophobic. Requires organic co-solvents (DMSO, tBuOH) to prevent precipitation in aqueous buffers.

## Workflow Visualization

The following diagram outlines the logical flow for utilizing **3-Chloro-5-ethynylisoquinoline** in a proteomic profiling context.

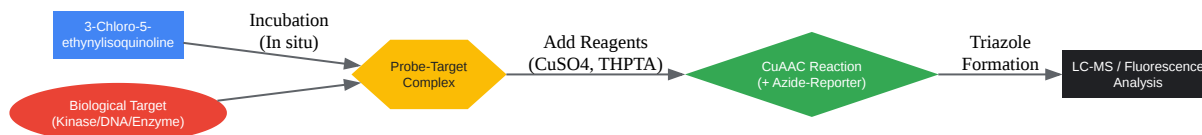

[Click to download full resolution via product page](#)

Figure 1: Workflow for Activity-Based Protein Profiling (ABPP) using the ethynyl-isoquinoline scaffold.

## Protocol 1: Two-Step Labeling in Complex Proteomes (Lysates)

This protocol is designed for researchers using **3-Chloro-5-ethynylisoquinoline** to identify binding targets in cell lysates. The hydrophobicity of the isoquinoline requires careful solvent management to prevent "crash-out" before the reaction occurs.

### Reagents Required

- Probe Stock: 10 mM **3-Chloro-5-ethynylisoquinoline** in anhydrous DMSO.
- Reporter Tag: 5 mM Azide-Biotin or Azide-Fluor 488 in DMSO.
- Catalyst: 50 mM CuSO<sub>4</sub> in sterile water.
- Ligand: 10 mM THPTA (Tris(3-hydroxypropyltriazolylmethyl)amine) in water. Note: THPTA is preferred over TBTA for aqueous solubility.
- Reductant: 100 mM Sodium Ascorbate (freshly prepared).
- Lysis Buffer: PBS (pH 7.4) + 0.1% Triton X-100 + Protease Inhibitors.

### Step-by-Step Procedure

- Proteome Preparation:
  - Dilute cell lysate to a protein concentration of 1–2 mg/mL in Lysis Buffer.
  - Critical: Avoid buffers with chelating agents like EDTA/EGTA, as they strip the Copper catalyst.
- Probe Incubation:
  - Add **3-Chloro-5-ethynylisoquinoline** stock to the lysate (Final Conc: 1–10  $\mu$ M).
  - Incubate for 1 hour at 37°C (or temperature relevant to target stability).
  - Control: Prepare a "No Probe" DMSO vehicle control.
- Click Chemistry Master Mix (Preparation):
  - Premix the reagents in the following order to form a stable catalyst complex (preventing Cu(I) disproportionation):
    1. THPTA Ligand (10 mM)
    2. CuSO<sub>4</sub> (50 mM) Ratio: Maintain a 1:5 ratio of Cu:Ligand (e.g., 2  $\mu$ L CuSO<sub>4</sub> + 10  $\mu$ L THPTA).
  - Vortex and incubate for 2 minutes.
- The Click Reaction:
  - Add the Azide-Reporter to the lysate (Final Conc: 20–50  $\mu$ M).
  - Add the Cu-THPTA Complex (Final Conc: 1 mM Cu).
  - Initiate reaction by adding Sodium Ascorbate (Final Conc: 5 mM).

- Total Organic Solvent Load: Ensure DMSO/tBuOH content stays <5% to prevent protein denaturation.
- Termination:
  - Vortex gently and incubate for 1 hour at Room Temperature in the dark.
  - Quench reaction by adding 4X SDS-PAGE Loading Buffer (containing ngcontent-ng-c2307461527="" \_ngghost-ng-c2764567632="" class="inline ng-star-inserted">-mercaptoethanol) or by protein precipitation (Methanol/Chloroform).

## Protocol 2: Chemical Synthesis of Bioconjugates (Preparative Scale)

For creating a purified conjugate (e.g., linking the isoquinoline to a drug delivery polymer or specific ligand) in a flask.

### Reaction Scheme Visualization

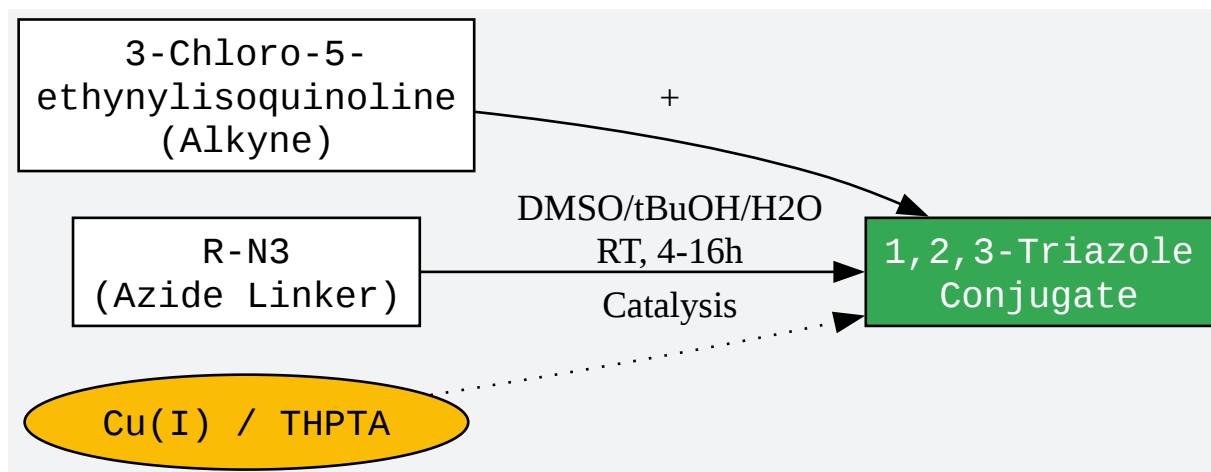

[Click to download full resolution via product page](#)

Figure 2: Preparative scale CuAAC reaction scheme.

## Methodology

- **Dissolution:** Dissolve **3-Chloro-5-ethynylisoquinoline** (1 eq) and the Azide partner (1.1 eq) in a mixture of DMSO:tBuOH (1:1).
  - Why tBuOH? Tert-butanol helps solubilize the organic heterocycle while remaining compatible with the aqueous copper catalyst.
- **Catalyst Addition:** Add 0.1 eq of CuSO<sub>4</sub> and 0.5 eq of THPTA (pre-complexed in minimal water).
- **Reduction:** Add 0.5 eq of Sodium Ascorbate.
- **Monitoring:** Stir at Room Temperature. Monitor consumption of the alkyne by TLC or LC-MS (Alkyne peak at ~2100 cm<sup>-1</sup> in IR will disappear).
- **Purification:**
  - Dilute with water (may precipitate the product if hydrophobic).
  - Extract with Ethyl Acetate.
  - Purify via Silica Gel Chromatography (DCM/MeOH gradient).

## Troubleshooting & Optimization

Issue	Probable Cause	Corrective Action
Precipitation of Probe	High hydrophobicity of the chloro-isoquinoline core.	Increase DMSO concentration (up to 10%) or add 20% t-Butanol to the reaction buffer.
Protein Degradation	Copper-induced oxidation.	Increase THPTA concentration (Ligand acts as a sacrificial antioxidant). Perform reaction at 4°C.
Low Yield	Oxygen poisoning of Cu(I).	Degas buffers with Nitrogen/Argon. Add fresh Sodium Ascorbate.
High Background	Non-specific binding of the Azide-dye.	Perform a "Pulse-Chase" experiment or wash protein pellets with cold Methanol prior to analysis.

## References

- Kolb, H. C., Finn, M. G., & Sharpless, K. B. (2001).[1] Click Chemistry: Diverse Chemical Function from a Few Good Reactions. *Angewandte Chemie International Edition*. [Link](#)
- Hong, V., Presolski, S. I., Ma, C., & Finn, M. G. (2009). Analysis and Optimization of Copper-Catalyzed Azide-Alkyne Cycloaddition for Bioconjugation. *Angewandte Chemie*. [Link](#)
- Speers, A. E., & Cravatt, B. F. (2004). Profiling Enzyme Activities In Vivo Using Click Chemistry Methods. *Chemistry & Biology*. [Link](#)
- Biosynth. (n.d.). 3-Chloroisoquinoline Product Data. Biosynth Catalog. [Link](#)
- Jao, C. Y., & Salic, A. (2008). Exploring RNA transcription and turnover in vivo with an alkyne nucleoside. *Proceedings of the National Academy of Sciences*. [Link](#)

### Need Custom Synthesis?

BenchChem offers custom synthesis for rare earth carbides and specific isotopic labeling.

Email: [info@benchchem.com](mailto:info@benchchem.com) or [Request Quote Online](#).

## Sources

- [1. Click chemistry - Wikipedia \[en.wikipedia.org\]](#)
- To cite this document: BenchChem. [Bioconjugation techniques involving 3-Chloro-5-ethynylisoquinoline]. BenchChem, [2026]. [Online PDF]. Available at: [\[https://www.benchchem.com/product/b1436038/docs#bioconjugation-techniques-involving-3-chloro-5-ethynylisoquinoline\]](https://www.benchchem.com/product/b1436038/docs#bioconjugation-techniques-involving-3-chloro-5-ethynylisoquinoline)

### Disclaimer & Data Validity:

The information provided in this document is for Research Use Only (RUO) and is strictly not intended for diagnostic or therapeutic procedures. While BenchChem strives to provide accurate protocols, we make no warranties, express or implied, regarding the fitness of this product for every specific experimental setup.

**Technical Support:** The protocols provided are for reference purposes. Unsure if this reagent suits your experiment?

**Need Industrial/Bulk Grade?** [Request Custom Synthesis Quote](#)

## BenchChem

Our mission is to be the trusted global source of essential and advanced chemicals, empowering scientists and researchers to drive progress in science and industry.

### Contact

Address: 3281 E Guasti Rd

Ontario, CA 91761, United States

Phone: (601) 213-4426

Email: [info@benchchem.com](mailto:info@benchchem.com)

Contact our Ph.D. Support Team for a compatibility check