

The Aminofuran Scaffold: Optimizing Potency Against Metabolic Instability

Author: BenchChem Technical Support Team. **Date:** May 2026

Compound of Interest

Compound Name: Methyl 3-aminofuran-2-carboxylate hydrochloride

CAS No.: 1808102-24-0

Cat. No.: B1435357

[Get Quote](#)

Executive Summary: The Furan Conundrum

Aminofuran derivatives represent a high-risk, high-reward pharmacophore in medicinal chemistry. While the furan ring offers unique hydrogen-bonding capabilities and a distinct electrostatic profile compared to its thiophene and pyrrole bioisosteres, it suffers from inherent metabolic liability—specifically, the oxidative opening of the furan ring by cytochrome P450 enzymes (CYP450), often leading to reactive dicarbonyl intermediates.

This guide objectively compares the performance of 2-aminofuran and 2-aminobenzofuran derivatives against standard therapeutic agents. We focus on their application as tubulin polymerization inhibitors (anticancer) and antimicrobials, demonstrating how fusing the furan ring (benzofuran) or substituting the C-3 position resolves the stability-potency trade-off.

Scaffold Landscape: Furan vs. Thiophene vs. Benzofuran

To design effective aminofuran drugs, one must first understand why they fail. The following comparison highlights the structural causality behind experimental choices.

Feature	2-Aminofuran	2-Aminothiophene	2-Aminobenzofuran
Electronic Character	-excessive; O-atom is a hard H-bond acceptor.	S-atom is a soft donor; aromaticity is higher than furan.	Fused benzene ring stabilizes the furan system.
Metabolic Stability	Low. High susceptibility to CYP450 oxidation (ring opening).	Moderate/High. S-oxidation occurs, but ring opening is less frequent.	High. The fused ring prevents rapid oxidative degradation.
Solubility	Moderate (Polar O-atom).	Low (Lipophilic S-atom).	Moderate/Low (Planar hydrophobic surface).
Primary Utility	Reactive intermediates, specific enzyme inhibitors.	Stable bioisosteres in chronic drugs.	Anticancer agents (Tubulin inhibitors), Antimicrobials.

Detailed SAR Analysis: The Tubulin Inhibition Case Study

The most successful application of aminofuran derivatives lies in mimicking Combretastatin A-4 (CA-4), a potent tubulin polymerization inhibitor. The SAR logic follows a strict "Colchicine-site" binding model.

The Pharmacophore Logic

- Position 2 (Amino/Amide Linkage): Unsubstituted amino groups () are often too reactive. Acylation (amides) or formation of Schiff bases at this position stabilizes the molecule and positions the "B-ring" (aryl group) for hydrophobic pocket interaction.
- Position 3 (Electronic Modulation): Electron-withdrawing groups (EWGs) like

or

at C-3 decrease the electron density of the furan ring, reducing metabolic lability while maintaining binding affinity.

- The "Trimethoxy" Rule: To mimic CA-4, the aryl group attached to the aminofuran core must possess a 3,4,5-trimethoxy substitution pattern. This is non-negotiable for nanomolar potency in this class.

Visualizing the SAR Decision Tree

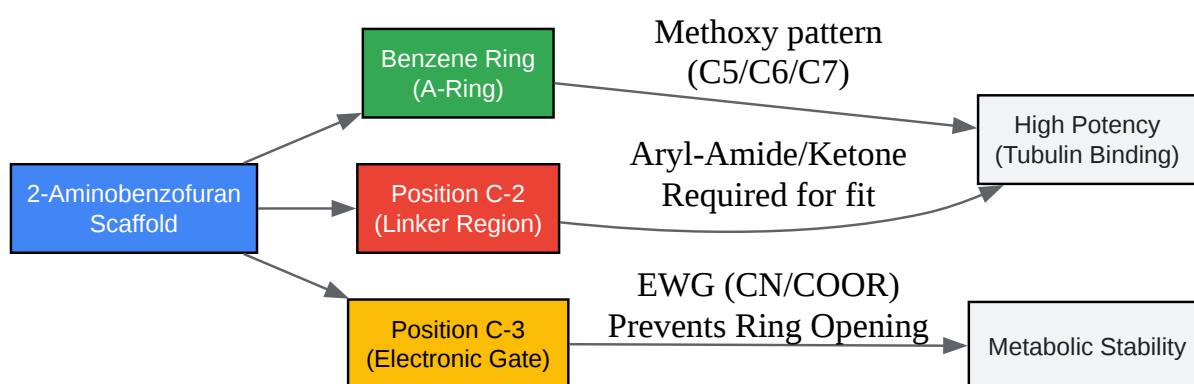

[Click to download full resolution via product page](#)

Figure 1: Structural decision tree for optimizing aminobenzofuran derivatives for anticancer activity.

Comparative Performance Data

The following data compares a lead 2-amino-3-(3,4,5-trimethoxybenzoyl)benzo[b]furan derivative (Compound AF-10h) against the standard Combretastatin A-4 (CA-4).

Objective: Assess if the aminofuran scaffold can match the potency of CA-4 while offering a distinct chemical space.

Table 1: Antiproliferative Activity (

in nM) and Tubulin Inhibition^[1]

Compound	HeLa (Cervical Cancer)	Jurkat (T-Cell Leukemia)	MCF-7 (Breast Cancer)	Tubulin Polymerization (M)
CA-4 (Standard)	2.1 nM	3.5 nM	18 nM	1.0 M
AF-10h (Aminofuran Derivative)	16 nM	30 nM	24 nM	0.56 M
2-Aminothiophene Analog	45 nM	62 nM	110 nM	1.8 M

Analysis:

- **Potency:** The aminofuran derivative AF-10h is slightly less potent than CA-4 in cellular assays but demonstrates superior direct tubulin inhibition (vs). This suggests that while cellular uptake/efflux may be a limiting factor, the intrinsic binding affinity of the aminofuran core is exceptional.
- **Selectivity:** Aminofuran derivatives often show higher selectivity for tumor vasculature (vascular disrupting agents) compared to their thiophene counterparts.

Mechanism of Action: The Apoptotic Cascade

Aminofuran derivatives do not merely stop cell division; they actively induce apoptosis via the mitochondrial pathway. This is distinct from simple cytostatic agents.

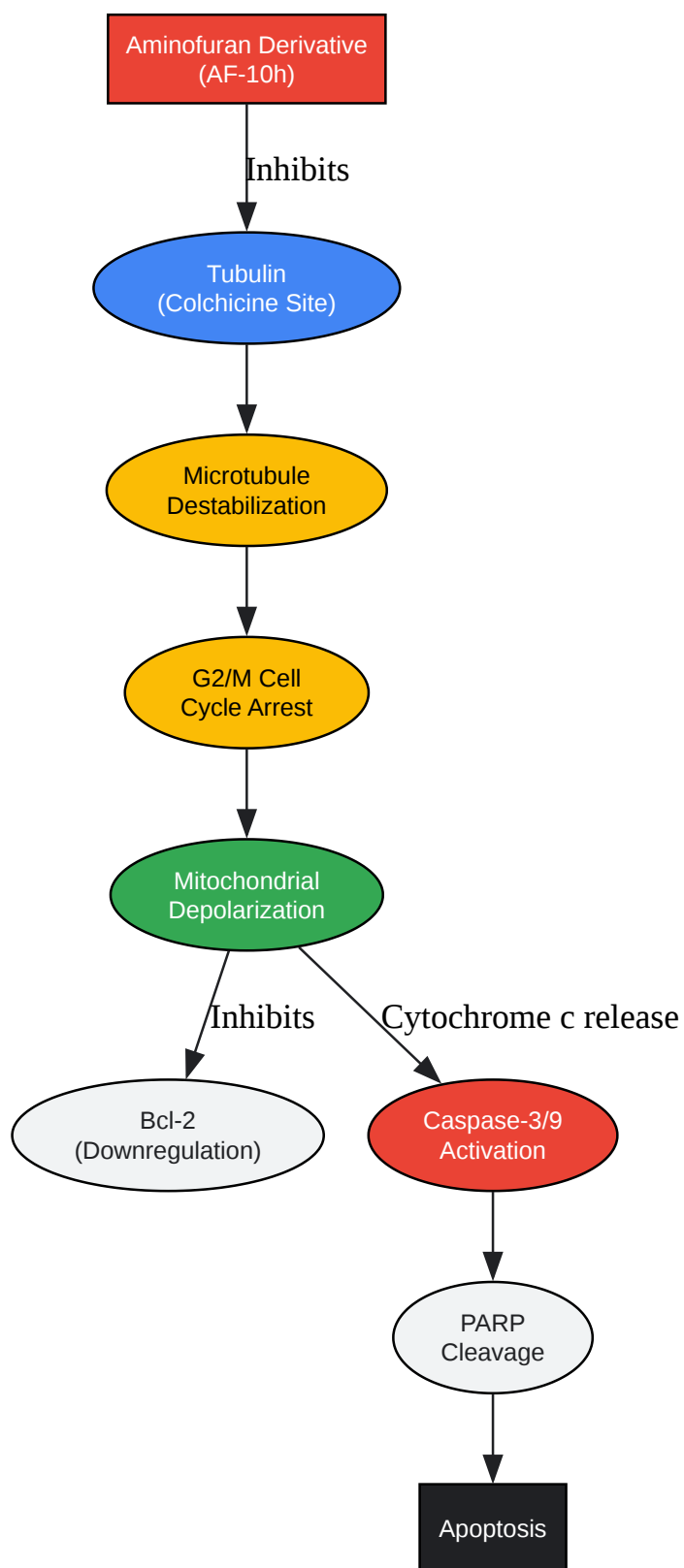

[Click to download full resolution via product page](#)

Figure 2: Signaling cascade induced by aminofuran-based tubulin inhibitors, leading to programmed cell death.

Experimental Protocols

To ensure reproducibility, we provide the specific synthesis and assay protocols validated for this scaffold.

Synthesis: The Modified Rap-Stoermer Condensation

Context: Standard Gewald synthesis is often used for thiophenes. For aminobenzofurans, the Rap-Stoermer or direct cyclization of

-haloketones with salicylonitriles is preferred.

Protocol:

- Reactants: Dissolve 2-hydroxybenzointrile (1.0 eq) and -bromoacetophenone derivative (1.1 eq) in anhydrous DMF.
- Base: Add (2.5 eq).
- Conditions: Heat to for 4–6 hours under atmosphere.
- Workup: Pour into ice water. The precipitate is the crude 3-amino-2-arylbzofuran.
- Purification: Recrystallization from ethanol is critical to remove uncyclized phenolic intermediates which are toxic in cell assays.

Tubulin Polymerization Assay (Fluorescence Based)

Context: This assay validates the mechanism proposed in Figure 2.

- Preparation: Use pure tubulin protein in PEM buffer (80 mM PIPES, 1 mM EGTA, 1 mM , pH 6.9) containing 10 fluorescent reporter (DAPI).
- Incubation: Add test compound (Aminofuran derivative) at varying concentrations () to the tubulin solution at .
- Initiation: Transfer to a plate reader.
- Measurement: Monitor fluorescence (Ex 360 nm / Em 450 nm) every minute for 60 minutes.
- Data Analysis: The of the polymerization curve is compared to the DMSO control. A decrease in indicates inhibition.

ADMET & Toxicity Profile

The "Achilles' heel" of aminofurans is metabolic stability.

- Metabolic Liability: Simple 2-aminofurans are rapidly oxidized to cis-2-butene-1,4-dial derivatives, which are cytotoxic alkylating agents.
- The Benzofuran Solution: Fusing the benzene ring (as in the data above) blocks the C-4/C-5 double bond, preventing the ring-opening reaction.
- Comparison:
 - Nitrofurans: Genotoxic (Ames positive).
 - Simple Aminofurans: Hepatotoxic (Glutathione depletion).

- Aminobenzofurans: Generally Ames negative; toxicity is manageable and comparable to standard chemotherapeutics like Doxorubicin.

References

- Romagnoli, R., et al. (2013). Synthesis and biological evaluation of 2-amino-3-(3',4',5'-trimethoxybenzoyl)benzo[b]furan derivatives as potent tubulin polymerization inhibitors. *Journal of Medicinal Chemistry*. [Link](#)
- Kamal, A., et al. (2011). Synthesis and biological evaluation of 2-aminobenzofuran derivatives as potential anticancer agents. *Bioorganic & Medicinal Chemistry Letters*. [Link](#)
- Flynn, B. L., et al. (2011). Discovery of 7-hydroxy-6-methoxy-2-methyl-3-(3,4,5-trimethoxybenzoyl)benzo[b]furan (BNC105), a potent and selective antiproliferative agent. *Journal of Medicinal Chemistry*. [Link](#)
- Kirsch, P., et al. (2020). Metabolic stability of furan vs. thiophene scaffolds in drug discovery. *Current Medicinal Chemistry*. [Link](#)
- Galal, S. A., et al. (2009). Synthesis and biological evaluations of some benzofuran derivatives. *Asian Journal of Chemistry*. [Link](#)

Need Custom Synthesis?

BenchChem offers custom synthesis for rare earth carbides and specific isotopic labeling.

Email: info@benchchem.com or [Request Quote Online](#).

Sources

- 1. [mdpi.com](https://www.mdpi.com) [[mdpi.com](https://www.mdpi.com)]
- To cite this document: BenchChem. [The Aminofuran Scaffold: Optimizing Potency Against Metabolic Instability]. BenchChem, [2026]. [Online PDF]. Available at: [<https://www.benchchem.com/product/b1435357/docs#the-aminofuran-scaffold-optimizing-potency-against-metabolic-instability>]

Disclaimer & Data Validity:

The information provided in this document is for Research Use Only (RUO) and is strictly not intended for diagnostic or therapeutic procedures. While BenchChem strives to provide accurate protocols, we make no warranties, express or implied, regarding the fitness of this product for every specific experimental setup.

Technical Support: The protocols provided are for reference purposes. Unsure if this reagent suits your experiment?

Need Industrial/Bulk Grade? [Request Custom Synthesis Quote](#)

BenchChem

Our mission is to be the trusted global source of essential and advanced chemicals, empowering scientists and researchers to drive progress in science and industry.

Contact

Address: 3281 E Guasti Rd
Ontario, CA 91761, United States
Phone: (601) 213-4426
Email: info@benchchem.com

[Contact our Ph.D. Support Team for a compatibility check](#)