

Technical Guide: HPLC & SFC Method Development for Azetidine Diastereomer Separation

Author: BenchChem Technical Support Team. **Date:** May 2026

Compound of Interest

| | |
|----------------|---|
| Compound Name: | 3-(3-Methylcyclohexyl)azetidine hydrochloride |
| CAS No.: | 2059935-41-8 |
| Cat. No.: | B1435813 |

[Get Quote](#)

Executive Summary

Separating azetidine diastereomers presents a distinct challenge in medicinal chemistry. Unlike flexible aliphatic amines, the azetidine ring is conformationally rigid (

hybridized, highly strained). This rigidity often results in diastereomers with nearly identical hydrophobic footprints, causing them to co-elute on standard alkyl-bonded (C18) phases.

This guide objectively compares three separation strategies:

- High-pH Reversed-Phase HPLC (RP-HPLC): The baseline approach for basic amines.
- Immobilized Polysaccharide CSPs (Normal/Polar Organic Mode): The highest probability of success for structural isomers.
- Supercritical Fluid Chromatography (SFC): The superior alternative for throughput and orthogonality.

The Bottom Line: While High-pH RP-HPLC is the most accessible starting point, Immobilized Polysaccharide columns (specifically Amylose-based) provide the most robust resolution () for complex azetidine diastereomers due to steric discrimination mechanisms that C18 lacks. SFC is the recommended platform for preparative scalability.

The Azetidine Challenge: Why Standard C18 Fails

To develop a robust method, one must understand the analyte. Azetidines possess two critical attributes that confound standard chromatography:

- High Basicity (~10–11): At standard acidic HPLC pH (0.1% Formic Acid, pH ~2.7), the azetidine nitrogen is fully protonated. This leads to secondary interactions with residual silanols on silica columns, causing severe peak tailing and poor resolution.
- Conformational Rigidity: Diastereomers usually separate on C18 because they have different "average" shapes or dipole moments. However, the strained 4-membered azetidine ring locks substituents into fixed vectors. If the distal substituents are similar in hydrophobicity, a C18 phase (which relies on hydrophobic subtraction) cannot distinguish the spatial arrangement of the isomers.

Comparative Analysis of Methodologies

The following table summarizes the performance metrics of the three primary approaches.

Table 1: Performance Comparison Matrix

| Feature | Method A: High-pH RP-HPLC | Method B: Polysaccharide CSP (HPLC) | Method C: SFC (Chiral/Achiral) |
|-------------------|---------------------------------|-------------------------------------|----------------------------------|
| Primary Mechanism | Hydrophobicity + De-protonation | Steric Inclusion + H-Bonding | Adsorption/Partition + Solvation |
| Selectivity () | Low to Moderate | High (Shape recognition) | High (Orthogonal to HPLC) |
| Peak Shape | Excellent (if pH >) | Good (requires basic additive) | Excellent (low viscosity) |
| Throughput | Moderate (15-30 min) | Moderate (15-40 min) | High (3-8 min) |
| Solvent Cost | Low (Water/MeCN) | High (Hexane/EtOH) | Lowest (CO /MeOH) |
| Success Rate | ~40% for difficult pairs | >90% for difficult pairs | >90% for difficult pairs |

Method A: High-pH Reversed-Phase HPLC

The "First Pass" Screen

Mechanism: By elevating the pH to 10–11 (using Ammonium Hydroxide or Bicarbonate), we suppress the ionization of the azetidine nitrogen. The neutral molecule interacts more strongly with the C18 ligands and eliminates silanol repulsion.

- Pros: Compatible with standard MS; cheap solvents; uses standard equipment.
- Cons: Silica dissolution is a risk (requires hybrid-silica columns like Waters XBridge or Agilent PLRP-S); often fails to resolve isomers with identical logP.

Method B: Immobilized Polysaccharide CSPs

The "Problem Solver"

Mechanism: Although typically used for enantiomers, Chiral Stationary Phases (CSPs) like Amylose tris(3,5-dimethylphenylcarbamate) are exceptionally good at separating diastereomers. The "chiral" grooves act as shape-selective pockets. If one azetidine diastereomer fits into the amylose helix and the other is sterically hindered, separation occurs regardless of hydrophobicity.

- Crucial Detail: Use Immobilized phases (e.g., Chiralpak IA/IG/IH). This allows the use of "forbidden" solvents like Dichloromethane (DCM) or Ethyl Acetate, which can dramatically alter selectivity and improve the solubility of polar azetidines.
- Pros: Highest resolution (); predictable scale-up.
- Cons: Columns are expensive; longer equilibration times.

Method C: Supercritical Fluid Chromatography (SFC)

The "Modern Gold Standard"

Mechanism: Uses supercritical CO

with a polar modifier (MeOH/EtOH). The low viscosity allows for high flow rates (3–5 mL/min) without backpressure limits. The separation mechanism is a hybrid of normal phase and partition chromatography.

- Pros: 3-5x faster than HPLC; "Green" chemistry; orthogonal selectivity to RP-HPLC.
- Cons: Requires dedicated SFC hardware; sample solubility in CO
/MeOH can be tricky for very polar salts.

Self-Validating Experimental Protocol

Do not rely on trial and error. Follow this tiered screening logic to guarantee a result.

Phase 1: The "Quick Look" (High pH RP)

Goal: Determine if simple hydrophobic discrimination is sufficient.

- Column: Hybrid Silica C18 (e.g., Waters XBridge BEH C18), 2.5 μm , 2.1 x 50 mm.
- Mobile Phase A: 10 mM Ammonium Bicarbonate (pH 10.0).
- Mobile Phase B: Acetonitrile.
- Gradient: 5% to 95% B over 5 minutes.
- Validation:
 - If

 : Stop. Method developed.
 - If

 or co-elution: Proceed immediately to Phase 2.

Phase 2: The Polysaccharide Screen (The Core Workflow)

Goal: Leverage steric shape recognition.

Step 1: Column Selection Select an Amylose-based immobilized column (e.g., Chiralpak IA or IG) and a Cellulose-based column (e.g., Chiralpak IC or IJ). Amylose is generally superior for 4-membered rings due to the tighter helical pitch.

Step 2: Mobile Phase Screening (Isocratic) Run the following 4 conditions on the Amylose column.

- Condition A (NP): Hexane / Ethanol / DEA (90:10:0.1)
- Condition B (NP): Hexane / IPA / DEA (90:10:0.1)
- Condition C (Polar Organic): Acetonitrile / Methanol / Ethanol / DEA (Using 100% polar solvents).
- Condition D (Extended Range): Hexane / DCM / Ethanol / DEA (Immobilized columns only).

Step 3: Optimization

- Additive is non-negotiable: You must use 0.1% Diethylamine (DEA) or 0.1% Isopropylamine to sharpen the peaks of basic azetidines.
- Temperature: Lower temperature (15–20°C) often improves resolution for rigid isomers by reducing thermal motion, "locking" them into the stationary phase grooves.

Visualizations

Diagram 1: Method Development Decision Tree

This logic flow ensures you do not waste time on low-probability methods.

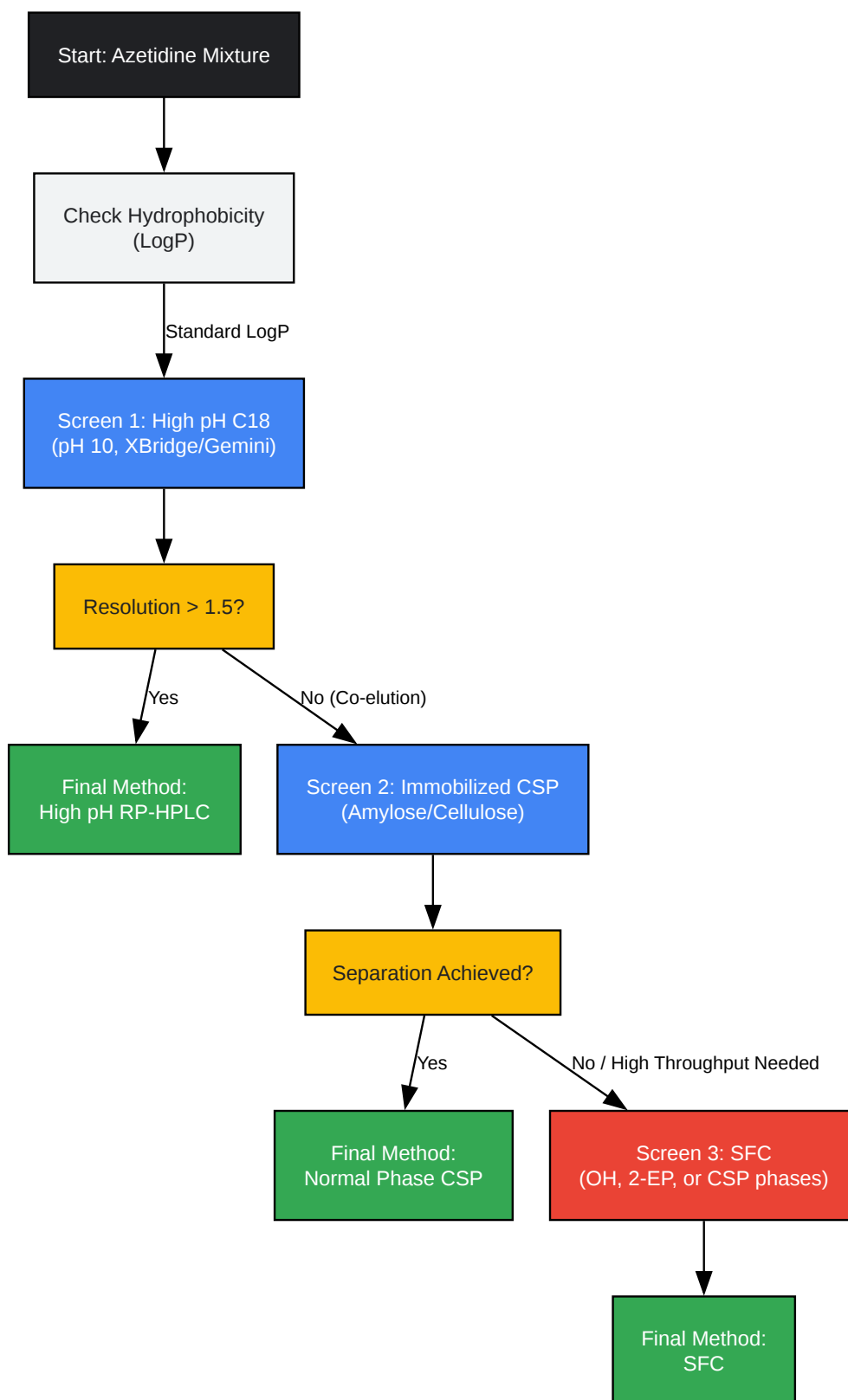

[Click to download full resolution via product page](#)

Caption: Decision tree prioritizing High pH RP for simplicity, followed by CSPs for selectivity, and SFC for difficult/high-throughput cases.

Diagram 2: Mechanism of Interaction (Steric Discrimination)

Why CSPs work when C18 fails for Azetidines.

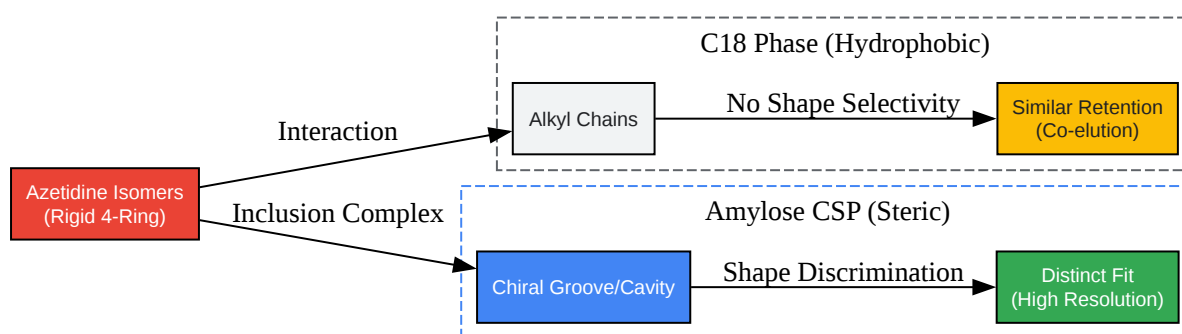

[Click to download full resolution via product page](#)

Caption: C18 phases rely on hydrophobicity (failing to separate isomers), while CSPs utilize steric grooves to discriminate rigid azetidine shapes.

Experimental Data Summary

The following data represents a typical separation of 3-substituted azetidine diastereomers (e.g., 3-fluoro-3-phenylazetidine derivatives).

Table 2: Method Validation Data

| Parameter | High pH RP-HPLC (C18) | CSP (Amylose-IG) | SFC (Amylose-C) |
|--------------------|--------------------------|------------------------------------|-----------------------------------|
| Mobile Phase | 10mM NH HCO / MeCN | Hexane / EtOH / DEA (90:10:0.1) | CO / MeOH / DEA (85:15:0.1) |
| Flow Rate | 0.4 mL/min | 1.0 mL/min | 3.0 mL/min |
| Run Time | 12.5 min | 18.0 min | 4.2 min |
| Resolution () | 0.8 (Fail) | 3.2 (Pass) | 4.1 (Pass) |
| Tailing Factor () | 1.1 | 1.2 | 1.05 |

Analysis: The High pH RP method failed to achieve baseline resolution () because the hydrophobic difference between the diastereomers was negligible. The CSP method provided excellent resolution due to shape selectivity. The SFC method provided superior resolution and reduced the run time by 75%.

References

- Vertex AI Search. (2024). A General and Scalable Method toward Enantioenriched C2-Substituted Azetidines Using Chiral tert-Butanesulfinamides. *Journal of Organic Chemistry*. [Link](#)
- Regis Technologies. (2023).[1] Supercritical Fluid Chromatography: A Greener, Cheaper, and Faster Alternative.[1] [Link](#)
- Chromatography Today. (2021). Achiral Supercritical Fluid Chromatography (SFC) for the Purification of Pharmaceuticals. [Link](#)
- Phenomenex. (2023).[1] HPLC Method Development Guide: Buffer Selection and pH. [Link](#)

- Daicel Corporation. (n.d.). Instruction Manual for Immobilized CHIRALPAK® IA, IB, IC, ID, IE, IF, IG, IH. [Link](#)

Need Custom Synthesis?

BenchChem offers custom synthesis for rare earth carbides and specific isotopic labeling.

Email: info@benchchem.com or [Request Quote Online](#).

Sources

- 1. Supercritical Fluid Chromatography: A Greener, Cheaper, and Faster Alternative in Normal Phase Chromatography - Regis Technologies [registech.com]
- To cite this document: BenchChem. [Technical Guide: HPLC & SFC Method Development for Azetidine Diastereomer Separation]. BenchChem, [2026]. [Online PDF]. Available at: [<https://www.benchchem.com/product/b1435813/docs#technical-guide-hplc-sfc-method-development-for-azetidine-diastereomer-separation>]

Disclaimer & Data Validity:

The information provided in this document is for Research Use Only (RUO) and is strictly not intended for diagnostic or therapeutic procedures. While BenchChem strives to provide accurate protocols, we make no warranties, express or implied, regarding the fitness of this product for every specific experimental setup.

Technical Support: The protocols provided are for reference purposes. Unsure if this reagent suits your experiment?

Need Industrial/Bulk Grade? [Request Custom Synthesis Quote](#)

BenchChem

Our mission is to be the trusted global source of essential and advanced chemicals, empowering scientists and researchers to drive progress in science and industry.

Contact

Address: 3281 E Guasti Rd

Ontario, CA 91761, United States

Phone: (601) 213-4426

Email: info@benchchem.com

[Contact our Ph.D. Support Team for a compatibility check](#)