

Comparison Guide: FTIR Characterization of 2,3,4-Trifluoro-5-nitrobenzaldehyde

Author: BenchChem Technical Support Team. **Date:** May 2026

Compound of Interest

Compound Name:	2,3,4-Trifluoro-5-nitrobenzaldehyde
CAS No.:	2044773-58-0
Cat. No.:	B1435313

[Get Quote](#)

Executive Summary

2,3,4-Trifluoro-5-nitrobenzaldehyde (CAS: 2044773-58-0) is a highly functionalized aromatic building block.^{[1][2][3]} Its high electron deficiency, driven by three fluorine atoms and a nitro group, creates a unique spectroscopic fingerprint distinct from its precursors.

This guide provides a comparative analysis to distinguish the target molecule from:

- The Precursor: 2,3,4-Trifluorobenzaldehyde (Non-nitrated).
- The Oxidation Byproduct: 2,3,4-Trifluoro-5-nitrobenzoic acid (Over-oxidized impurity).^[1]

Key Differentiator: The simultaneous presence of the Aldehyde Fermi Doublet (~2850/2750 cm^{-1}) and the Nitro Asymmetric Stretch (~1545 cm^{-1}) is the definitive "fingerprint" for acceptance.

Spectroscopic Profile & Comparative Analysis

The electron-withdrawing nature of the fluorine and nitro substituents shifts the carbonyl () absorption to a higher wavenumber compared to unsubstituted benzaldehyde ().

Table 1: Characteristic Peak Assignment & Comparison

Functional Group	Vibration Mode	Target Molecule(2,3,4-Trifluoro-5-nitrobenzaldehyde)	Alternative A(Precursor: No -NO ₂ group)	Alternative B(Acid Impurity: -COOH)
Aldehyde (C-H)	Stretch (Fermi Resonance)	PresentDoublet: ~2860 & 2760 cm ⁻¹	PresentDoublet: ~2850 & 2750 cm ⁻¹	Absent(Replaced by broad OH)
Carbonyl (C=O)	Stretching	~1715 – 1725 cm ⁻¹ (Shifted up due to -F/-NO ₂)	~1710 cm ⁻¹ (Lower shift, less EWG)	~1700 – 1710 cm ⁻¹ (Broadened by H-bonding)
Nitro (-NO ₂)	Asymmetric Stretch	~1540 – 1555 cm ⁻¹ (Strong, Sharp)	Absent(Key differentiator)	Present~1540 cm ⁻¹
Nitro (-NO ₂)	Symmetric Stretch	~1345 – 1360 cm ⁻¹	Absent	Present
Hydroxyl (-OH)	O-H Stretch	Absent	Absent	Present (Strong)Broad: 2500–3300 cm ⁻¹
Aromatic Ring	C=C Stretch	~1610 & 1490 cm ⁻¹	~1600 & 1480 cm ⁻¹	~1610 & 1490 cm ⁻¹
Carbon-Fluorine	C-F Stretch	~1000 – 1250 cm ⁻¹ (Multiple strong bands)	Present	Present

“

Analyst Note: The most common failure mode in synthesis is incomplete nitration. If the peak at 1545 cm^{-1} is weak or absent, the batch contains significant unreacted precursor. Conversely, a "hump" between $2500\text{--}3300\text{ cm}^{-1}$ indicates oxidation to the benzoic acid derivative.

Mechanistic Visualization

The following diagram illustrates the structural logic linking the functional groups to their specific wavenumbers.

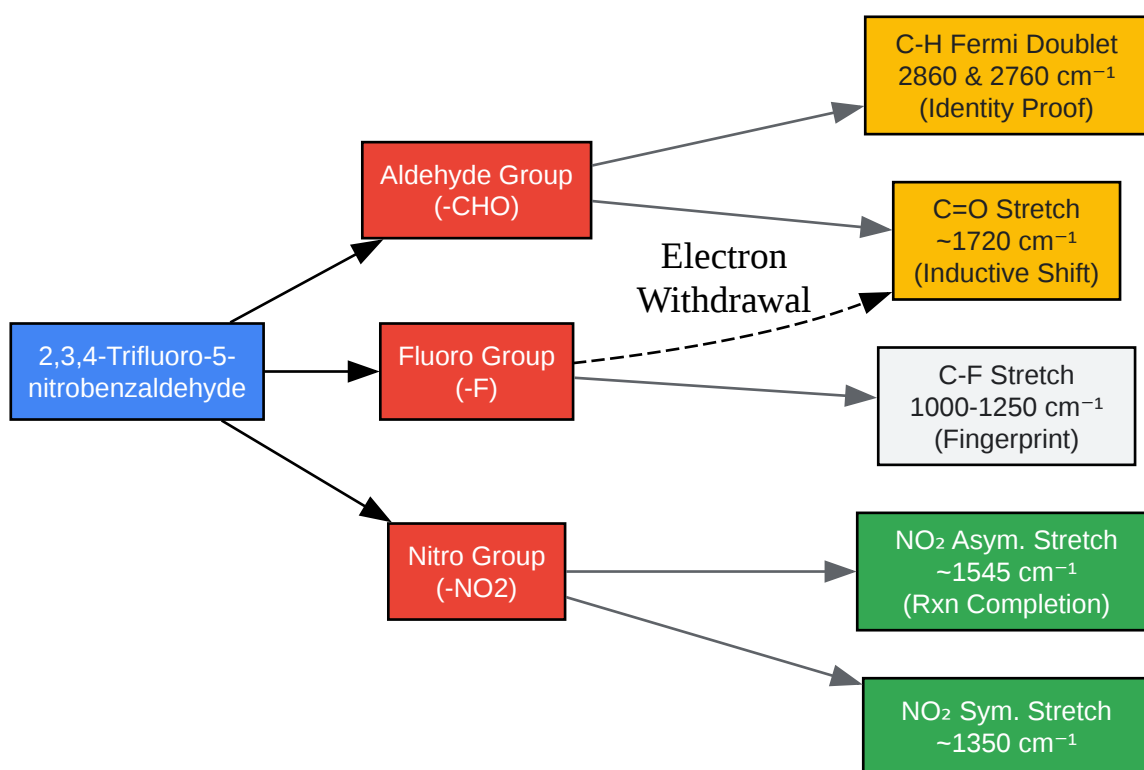

[Click to download full resolution via product page](#)

Figure 1: Vibrational mapping of functional groups to characteristic wavenumbers.

Experimental Protocol (ATR-FTIR)

This protocol uses Attenuated Total Reflectance (ATR) for rapid QC without KBr pellet preparation, minimizing moisture interference.

Materials & Equipment[1][6][7][8]

- Instrument: FTIR Spectrometer (e.g., PerkinElmer Spectrum Two or Thermo Nicolet iS50).
- Accessory: Diamond or ZnSe ATR Crystal.
- Solvent: Isopropanol (HPLC Grade) for cleaning.

Step-by-Step Workflow

- System Blanking:
 - Clean the ATR crystal with isopropanol and lint-free tissue.[1]
 - Collect a background spectrum (Air) with the same parameters as the sample (32 scans, 4 cm^{-1} resolution).
- Sample Loading:
 - Place approximately 5–10 mg of the yellow/cream crystalline powder onto the center of the crystal.
 - Apply pressure using the anvil until the force gauge reads the optimal value (usually ~80–100 N) to ensure good contact.
- Data Acquisition:
 - Range: 4000 – 600 cm^{-1} .
 - Resolution: 4 cm^{-1} .[4]
 - Scans: 32 (Routine QC) or 64 (High Precision).
- Post-Run Cleaning:
 - Wipe the crystal immediately. Nitro-aromatics can stain ZnSe crystals if left prolonged.[1]

Quality Control Decision Tree

Use this logic flow to determine batch disposition based on the spectral data.

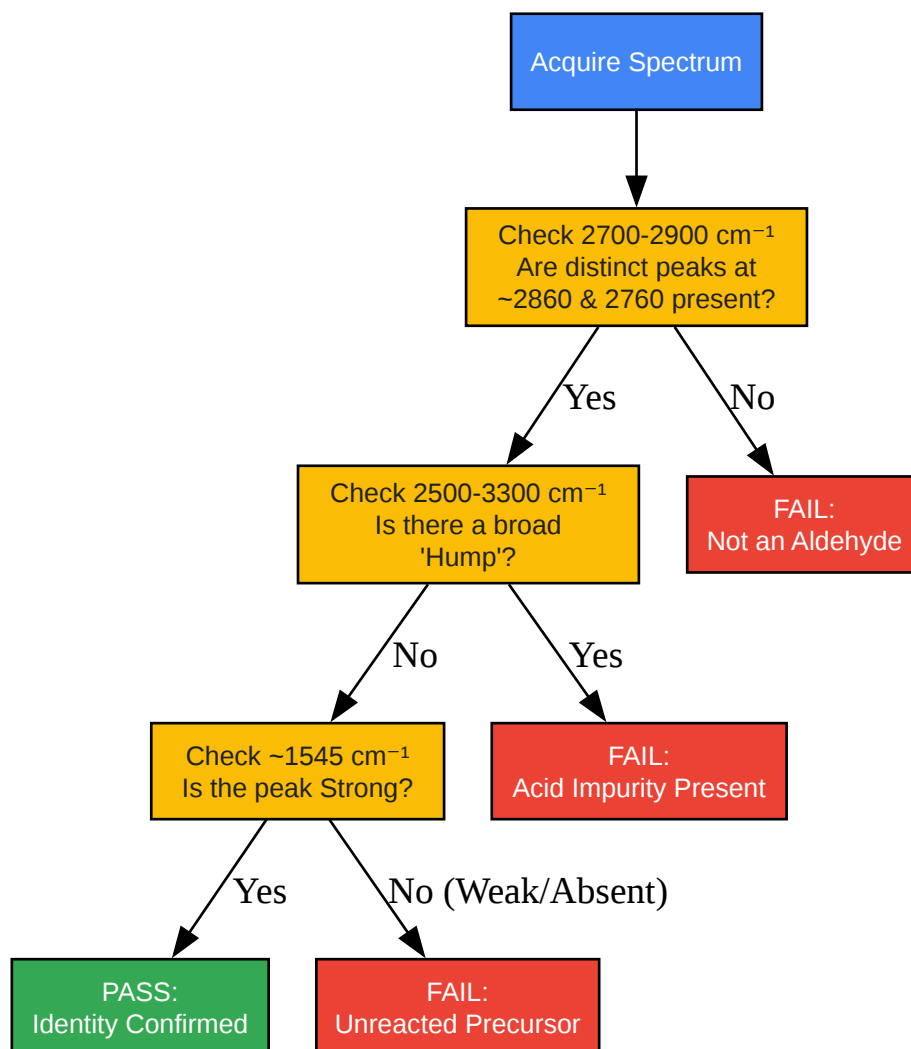

[Click to download full resolution via product page](#)

Figure 2: QC Decision Tree for batch release.

References

- NIST Chemistry WebBook. (2023). Infrared Spectra of Nitrobenzaldehydes. Standard Reference Data. Retrieved from [\[Link\]](#)[4]
- Coates, J. (2000). Interpretation of Infrared Spectra, A Practical Approach. In Encyclopedia of Analytical Chemistry. John Wiley & Sons.[5] (Standard reference for Fermi resonance and

nitro group assignments).

- Silverstein, R. M., et al. (2014). Spectrometric Identification of Organic Compounds (8th ed.). Wiley.[5] (Source for inductive shift of Carbonyls by Fluorine).

Need Custom Synthesis?

BenchChem offers custom synthesis for rare earth carbides and specific isotopic labeling.

Email: info@benchchem.com or [Request Quote Online](#).

Sources

- 1. [197520-71-1|2,3,4-Trifluoro-5-nitrobenzoic acid|BLD Pharm \[bldpharm.com\]](#)
- 2. [1807068-56-9|4-Fluoro-2-methyl-5-nitrobenzaldehyde|BLD Pharm \[bldpharm.com\]](#)
- 3. [679840-20-1|2,3-Difluoro-5-nitrobenzaldehyde|BLD Pharm \[bldpharm.com\]](#)
- 4. [Benzaldehyde, 2-nitro- \[webbook.nist.gov\]](#)
- 5. [Infrared spectroscopy correlation table - Wikipedia \[en.wikipedia.org\]](#)
- To cite this document: BenchChem. [Comparison Guide: FTIR Characterization of 2,3,4-Trifluoro-5-nitrobenzaldehyde]. BenchChem, [2026]. [Online PDF]. Available at: [\[https://www.benchchem.com/product/b1435313/docs#comparison-guide-ftir-characterization-of-2-3-4-trifluoro-5-nitrobenzaldehyde\]](https://www.benchchem.com/product/b1435313/docs#comparison-guide-ftir-characterization-of-2-3-4-trifluoro-5-nitrobenzaldehyde)

Disclaimer & Data Validity:

The information provided in this document is for Research Use Only (RUO) and is strictly not intended for diagnostic or therapeutic procedures. While BenchChem strives to provide accurate protocols, we make no warranties, express or implied, regarding the fitness of this product for every specific experimental setup.

Technical Support: The protocols provided are for reference purposes. Unsure if this reagent suits your experiment?

Need Industrial/Bulk Grade? [Request Custom Synthesis Quote](#)

BenchChem

Our mission is to be the trusted global source of essential and advanced chemicals, empowering scientists and researchers to drive progress in science and industry.

Contact

Address: 3281 E Guasti Rd

Ontario, CA 91761, United States

Phone: (601) 213-4426

Email: info@benchchem.com

[Contact our Ph.D. Support Team for a compatibility check](#)