

Mass Spectrometry Fragmentation Pattern of Thiazole Methyl Esters

Author: BenchChem Technical Support Team. **Date:** May 2026

Compound of Interest

Compound Name: Methyl 4-(4-methyl-1,3-thiazol-2-yl)butanoate
CAS No.: 1803586-63-1
Cat. No.: B1434861

[Get Quote](#)

Executive Summary

Thiazole methyl esters are critical pharmacophores in drug development, serving as precursors for antibiotics (e.g., thiazolyl peptides) and antineoplastic agents. Their mass spectrometric (MS) characterization requires distinguishing them from isomeric isothiazoles and homologous ethyl esters.

This guide provides a technical comparison of the fragmentation behaviors of Thiazole Methyl Esters (specifically methyl thiazole-4-carboxylate and its regioisomers) against key alternatives.

Key Technical Takeaways:

- **Diagnostic Stability:** Thiazole methyl esters exhibit a robust molecular ion () in Electron Ionization (EI), unlike ethyl esters which often degrade via McLafferty rearrangements.

- **Regioisomer Differentiation:** The "Ortho-Effect" allows differentiation between 4,5-disubstituted thiazoles (adjacent substituents) and 2,4- or 2,5-isomers.
- **Ring Integrity:** Unlike isothiazoles, which are prone to N-S bond cleavage, thiazoles predominantly fragment via H-C

N expulsion and CO loss.

Mechanistic Deep Dive: The Thiazole Methyl Ester

The fragmentation of thiazole methyl esters under Electron Ionization (70 eV) is governed by two competing pathways: Ester

-Cleavage and Thiazole Ring Fission.

Primary Fragmentation Pathway (Ester-Driven)

The most abundant ions arise from the ester functionality.

- **-Cleavage:** Homolytic cleavage of the C-O bond yields the acylium ion (). This is typically the Base Peak or second most abundant ion.
- **Decarbonylation:** The acylium ion subsequently loses carbon monoxide (CO) to form the thiazolyl cation.

Secondary Fragmentation Pathway (Ring-Driven)

Following ester degradation, the thiazole ring undergoes characteristic cleavage:

- **HCN Elimination:** A signature of 1,3-azoles. The ring expels hydrogen cyanide (HCN, 27 Da), resulting in a thiirene-like cation.
- **RDA-like Cleavage:** Retro-Diels-Alder fragmentation is less common in fully aromatic thiazoles but can occur in reduced derivatives.

The "Ortho-Effect" (Regioisomer Specificity)

This is the critical differentiator for researchers.

- Scenario: In Methyl 4-methylthiazole-5-carboxylate, the methyl group at C4 and the ester at C5 are adjacent.
- Mechanism: A hydrogen atom transfers from the C4-methyl group to the carbonyl oxygen of the ester via a 6-membered transition state, followed by the elimination of methanol (, 32 Da).
- Result: An intense peak at is observed.
- Contrast: Isomers like Methyl 2-methylthiazole-4-carboxylate lack this proximity, showing negligible abundance.

Comparative Analysis

Comparison 1: Thiazole Methyl Esters vs. Thiazole Ethyl Esters

Objective: Evaluate structural stability and spectral clarity.

Feature	Thiazole Methyl Ester (Product)	Thiazole Ethyl Ester (Alternative)
Molecular Ion ()	High Intensity. The methyl group cannot participate in McLafferty rearrangement.	Low/Absent. Rapid degradation via McLafferty rearrangement.
Diagnostic Loss	Loss of (M-31).	Loss of (M-45) AND Loss of (M-28).
Base Peak Origin	Often the Acylium ion ().	Often the carboxylic acid radical cation ().
Spectral Complexity	Low. Clean spectra ideal for library matching.	High. Multiple competing pathways clutter the low-mass region.

Verdict: For initial structural confirmation, Methyl Esters are superior due to the preservation of the molecular ion. Ethyl esters are preferred only when specific side-chain lability is required for MS/MS transitions.

Comparison 2: Thiazole vs. Isothiazole Methyl Esters

Objective: Distinguish between heterocyclic isomers (1,3-S,N vs. 1,2-S,N).

Feature	Thiazole (1,3-S,N)	Isothiazole (1,2-S,N)
Ring Cleavage	HCN Elimination. Loss of 27 Da is characteristic.	N-S Bond Fission. Weakest bond breaks first.
Characteristic Fragment	Thioformyl cation (, m/z 45).	Nitrile cation () dominates.
Stability	Higher aromatic stability; is more intense.	Lower stability; extensive fragmentation.

Verdict: The presence of a strong

ion (m/z 45) strongly supports the Thiazole core over the Isothiazole.

Visualization of Fragmentation Pathways[1][2][3][4][5]

Diagram 1: Fragmentation of Methyl Thiazole-4-carboxylate

This diagram illustrates the primary pathways, including the diagnostic loss of the methoxy radical and subsequent ring opening.

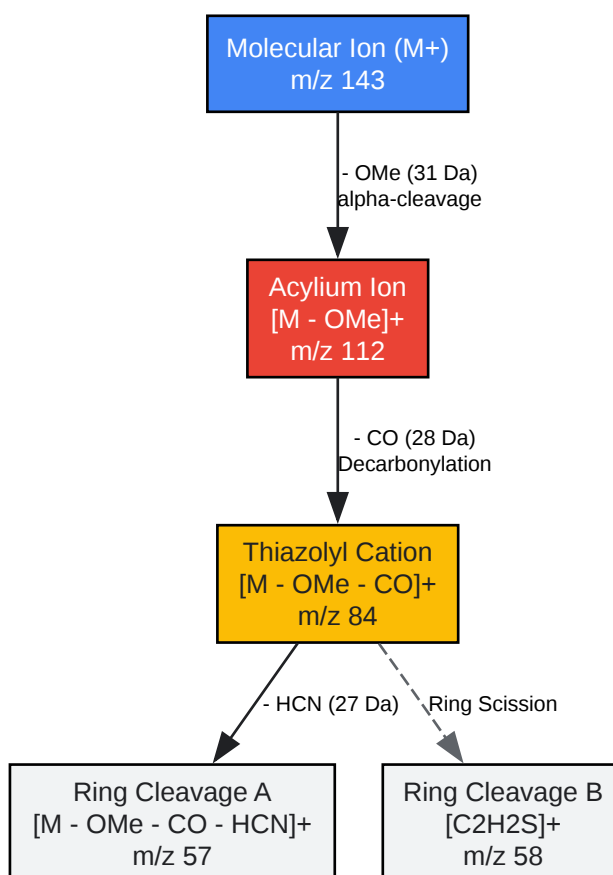

[Click to download full resolution via product page](#)

Caption: Primary fragmentation pathway of Methyl Thiazole-4-carboxylate under 70 eV EI conditions.

Diagram 2: The "Ortho-Effect" Decision Tree

Use this logic flow to differentiate regioisomers based on spectral data.

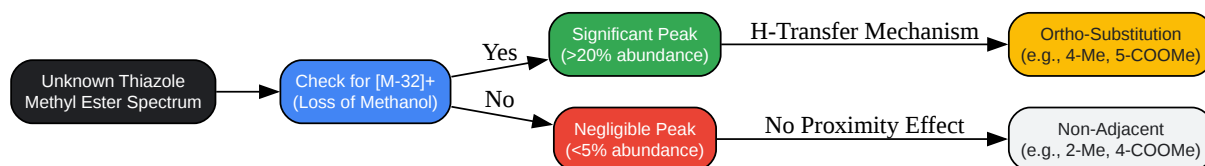

[Click to download full resolution via product page](#)

Caption: Decision tree for differentiating thiazole regioisomers using the Ortho-Effect.

Experimental Protocol (Self-Validating)

To reproduce the fragmentation patterns described above, use the following standardized GC-MS protocol.

Scope: Analysis of volatile thiazole methyl esters.

1. Sample Preparation:

- Dissolve 1 mg of the thiazole ester in 1 mL of HPLC-grade Methanol or Dichloromethane.
- Validation Step: Ensure solution is clear; turbidity indicates polymerization or salt formation.

2. GC Parameters:

- Column: DB-5ms (or equivalent 5% phenyl-methylpolysiloxane), 30m x 0.25mm ID.
- Carrier Gas: Helium at 1.0 mL/min (constant flow).
- Temperature Program:
 - Hold 60°C for 1 min.
 - Ramp 20°C/min to 280°C.

- Hold 3 min.

3. MS Parameters (The Critical Variable):

- Ionization: Electron Ionization (EI).[\[1\]](#)[\[2\]](#)[\[3\]](#)
- Energy: 70 eV (Standard).[\[2\]](#) Note: Lowering to 20 eV will enhance the molecular ion but suppress diagnostic fragmentation.
- Source Temp: 230°C.
- Scan Range: m/z 40 – 300.

4. Data Validation Criteria:

- S/N Ratio: The Molecular Ion () must have a Signal-to-Noise ratio > 10:1.
- Isotope Check: Verify the presence of the isotope peak () at ~4.4% intensity relative to . If this is missing, the compound is not a thiazole.

References

- NIST Mass Spectrometry Data Center. Thiazole, 2-methyl-, Mass Spectrum.[\[3\]](#)[\[4\]](#) National Institute of Standards and Technology.[\[5\]](#) Available at: [\[Link\]](#)
- Salem, M. A. I., et al. (2014). Mass Spectral Fragmentation Modes of Some New Pyrimidinethiones, Thiazolo[3,2-a]Pyrimidines. International Journal of Materials and Chemistry.[\[1\]](#) Available at: [\[Link\]](#)
- Bowie, J. H., et al. (1967). Studies in mass spectrometry.[\[1\]](#)[\[2\]](#)[\[4\]](#)[\[6\]](#)[\[7\]](#) Part VII. Mass spectra of thiazoles. Journal of the Chemical Society B. Available at: [\[Link\]](#)

- Lebedev, A. T. (2010). Ortho effects in the mass spectra of derivatives of hydroxy-, mercapto and aminobenzenecarboxylic acids.[8][7] ResearchGate.[7] Available at: [\[Link\]](#)

Need Custom Synthesis?

BenchChem offers custom synthesis for rare earth carbides and specific isotopic labeling.

Email: info@benchchem.com or [Request Quote Online](#).

Sources

- [1. researchgate.net \[researchgate.net\]](https://www.researchgate.net)
- [2. uni-saarland.de \[uni-saarland.de\]](https://www.uni-saarland.de)
- [3. Thiazole, 2-methyl- \[webbook.nist.gov\]](https://webbook.nist.gov)
- [4. 2-Methylthiazole | C4H5NS | CID 77129 - PubChem \[pubchem.ncbi.nlm.nih.gov\]](https://pubchem.ncbi.nlm.nih.gov)
- [5. Thiazole, 2-methyl- \[webbook.nist.gov\]](https://webbook.nist.gov)
- [6. Multi-functional derivatization of amine, hydroxyl, and carboxylate groups for metabolomic investigations of human tissue by electrospray ionization mass spectrometry - Analyst \(RSC Publishing\) \[pubs.rsc.org\]](https://pubs.rsc.org)
- [7. researchgate.net \[researchgate.net\]](https://www.researchgate.net)
- [8. Mass spectrometry of analytical derivatives. 2. "Ortho" and "Para" effects in electron ionization mass spectra of derivatives of hydroxy, mercapto and amino benzoic acids - PMC \[pmc.ncbi.nlm.nih.gov\]](https://pubmed.ncbi.nlm.nih.gov)
- To cite this document: BenchChem. [Mass Spectrometry Fragmentation Pattern of Thiazole Methyl Esters]. BenchChem, [2026]. [Online PDF]. Available at: [\[https://www.benchchem.com/product/b1434861/docs#mass-spectrometry-fragmentation-pattern-of-thiazole-methyl-esters\]](https://www.benchchem.com/product/b1434861/docs#mass-spectrometry-fragmentation-pattern-of-thiazole-methyl-esters)

Disclaimer & Data Validity:

The information provided in this document is for Research Use Only (RUO) and is strictly not intended for diagnostic or therapeutic procedures. While BenchChem strives to provide accurate protocols, we make no warranties, express or implied, regarding the fitness of this product for every specific experimental setup.

Technical Support: The protocols provided are for reference purposes. Unsure if this reagent suits your experiment?

Need Industrial/Bulk Grade? [Request Custom Synthesis Quote](#)

BenchChem

Our mission is to be the trusted global source of essential and advanced chemicals, empowering scientists and researchers to drive progress in science and industry.

Contact

Address: 3281 E Guasti Rd
Ontario, CA 91761, United States
Phone: (601) 213-4426
Email: info@benchchem.com

[Contact our Ph.D. Support Team for a compatibility check](#)