

Application Note: High-Throughput Screening of Dispiro[3.1.3.1]decane Libraries

Author: BenchChem Technical Support Team. **Date:** May 2026

Compound of Interest

Compound Name: *Dispiro[3.1.3(6).1(4)]decane-2-carboxylic acid*

CAS No.: 91968-35-3

Cat. No.: B1434347

[Get Quote](#)

Executive Summary

The pharmaceutical industry's "escape from flatland" has catalyzed a shift from planar, aromatic-dominated libraries to three-dimensional, Fsp³-rich architectures. Among these, the dispiro[3.1.3.1]decane scaffold represents a privileged, under-explored chemical space. Characterized by a central cyclobutane ring spiro-fused to two terminal cyclobutane rings, this scaffold offers unique vectors for side-chain presentation, high metabolic stability, and a distinct "bow-shaped" topography that mimics non-planar biological metabolites.

This guide details the protocols for the high-throughput screening (HTS) of dispiro[3.1.3.1]decane libraries. Unlike standard heterocyclic libraries, these saturated systems present specific challenges in solubility profiling, quality control (QC) due to low UV absorbance, and acoustic handling. This document provides a self-validating workflow to maximize hit rates and data integrity.

Scaffold Architecture & Library Logic

The Dispiro[3.1.3.1]decane Core

The dispiro[3.1.3.1]decane system consists of three linearly fused four-membered rings connected via two spiro-quaternary carbons.

- **Geometry:** Crystallographic data indicates the central cyclobutane ring is puckered, creating a rigid, concave "bow" shape. This allows the molecule to wrap around target residues or fit into cryptic pockets inaccessible to flat aromatics.
- **Physicochemical Profile:** High fraction of saturated carbons ($F_{sp^3} \approx 1.0$ for the core) correlates with improved solubility and reduced promiscuity compared to lipophilic aromatic systems.

Library Design Strategy

To generate HTS-ready libraries, the core is typically functionalized at the 2,2- and 8,8-positions (terminal rings).

- **Diversity Points:** Esters, amides, or amines at the terminal rings allow for the introduction of diverse pharmacophores.
- **Stereochemical Considerations:** The rigid spiro-fusion creates distinct diastereomers (cis/trans relative to the central plane). Libraries are often separated into defined diastereomeric pairs prior to screening to simplify SAR.

Protocol A: Library Formatting & Quality Control (QC)

Challenge: The saturated dispiro[3.1.3.1]decane core lacks significant chromophores. Standard UV-based QC (254 nm) is insufficient and will yield false "empty well" signals.

Solution: Universal detection using Charged Aerosol Detection (CAD) or Mass Spectrometry (MS).

Materials

- **Compound Source:** Dispiro[3.1.3.1]decane library (10 mM in DMSO).

- LC System: UPLC coupled with SQ (Single Quadrupole) MS and CAD.
- Plate Type: 384-well Cyclo-olefin Copolymer (COC) plates (minimizes DMSO leaching and compound adsorption).

Step-by-Step QC Protocol

- Thawing: Thaw library plates at room temperature (25°C) for 60 minutes. Vortex at 1000 rpm for 30 seconds.
- Visual Inspection: Check for precipitation. Spirocycles are generally soluble, but "brick dust" formation can occur with lipophilic side chains.
- LC-MS/CAD Analysis (Random Sampling):
 - Sample 5% of the library (randomized).
 - Column: C18 Reverse Phase, 1.7 μm , 2.1 x 50 mm.
 - Mobile Phase: Water/Acetonitrile + 0.1% Formic Acid.
 - Detection: Set MS to ESI+ mode. Set CAD evaporation temp to 35°C.
 - Critical Check: Ensure purity > 85% by CAD integration (more accurate than UV for this scaffold).
- Reformatting: Transfer validated compounds to "Source Plates" (LDV - Low Dead Volume) for acoustic dispensing.

Protocol B: Acoustic HTS Workflow

This protocol utilizes acoustic liquid handling (e.g., Labcyte Echo) to dispense nanoliter volumes, preserving the library and eliminating tip-based cross-contamination.

Experimental Design (Case Study: Protease Inhibition)

- Target: Cysteine Protease (requires specific steric fit).
- Format: 1536-well black, solid-bottom plates.

- Assay Volume: 6 μ L total.

Workflow Diagram

The following diagram illustrates the critical path from library source to hit identification, highlighting the specific QC steps required for non-chromophoric scaffolds.

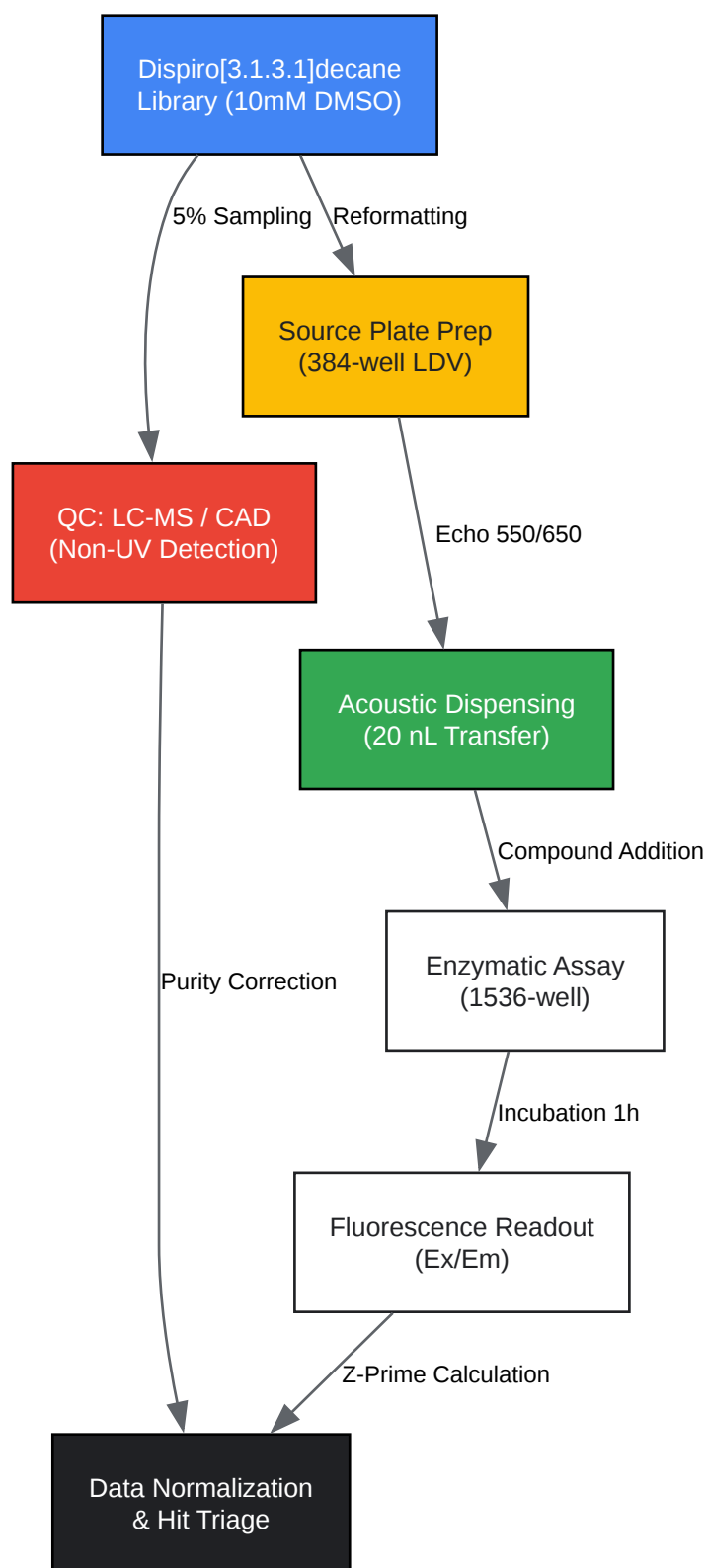

[Click to download full resolution via product page](#)

Figure 1: HTS workflow emphasizing the necessity of CAD/MS QC for saturated scaffolds.

Step-by-Step Screening Protocol

- Assay Plate Prep:
 - Dispense 3 μ L of Enzyme Buffer into 1536-well plates using a bulk dispenser (e.g., Multidrop Combi).
- Compound Transfer (Acoustic):
 - Use the Acoustic Liquid Handler to transfer 20 nL of compound from the Source Plate to the Assay Plate.
 - Controls: Transfer 20 nL DMSO to Columns 1-2 (High Control) and 20 nL Reference Inhibitor to Columns 3-4 (Low Control).
- Substrate Addition:
 - Dispense 3 μ L of Fluorogenic Substrate to initiate the reaction.
 - Centrifuge plate at 1000 x g for 1 minute to remove bubbles.
- Incubation:
 - Incubate at room temperature for 60 minutes (protected from light).
- Detection:
 - Read fluorescence (e.g., Ex 355 nm / Em 460 nm) on a multimode plate reader.

Data Analysis & Hit Triage

Quantitative Metrics

Data should be normalized to Percent Inhibition (PIN) relative to controls.

Metric	Acceptance Criteria	Notes
Z' Factor	> 0.5	Measures assay robustness.
Signal-to-Background	> 3:1	Essential for detecting weak binders.
CV (Control Wells)	< 5%	Indicates pipetting precision.
Hit Cutoff	Mean + 3 σ	Statistical definition of a hit.

Artifact Identification (The "Spiro-Specific" Triage)

While dispiro scaffolds are less prone to aggregation than aromatics, they can exhibit specific artifacts:

- **Fluorescence Interference:** The rigid core is generally inert, but specific amine-functionalized side chains may fluoresce. Action: Run a "Compound Only" control plate (no enzyme).
- **Stereoisomer Bias:** If the library contains racemic mixtures, a hit might represent only 50% active species. Action: Deconvolute hits by synthesizing/separating pure diastereomers (cis/trans).

Structural Validation

Confirm the identity of the hit using the exact mass.

- **Note:** Dispiro[3.1.3.1]decane derivatives often show distinct fragmentation patterns in MS/MS (loss of cyclobutane ring fragments).

References

- Burkhard, J. A., et al. (2010). "Escape from Flatland: Increasing Saturation as an Approach to Improving Clinical Success." *Journal of Medicinal Chemistry*. [[Link](#)]
- Fitjer, L., et al. (1990). "Structures of a spiro[3.3]heptane and a related dispiro[3.1.3.1]decane derivative." *Acta Crystallographica Section C*. [[Link](#)]

- Zheng, W., et al. (2013). "The Use of Spiked Compounds in High-Throughput Screening to Detect Interference." *Assay and Drug Development Technologies*. [[Link](#)]
- Stotani, S., et al. (2016).^[1] "Design and Synthesis of Fsp3-Rich, Bis-Spirocyclic-Based Compound Libraries for Biological Screening." *ACS Combinatorial Science*. [[Link](#)]
- Ellson, R., et al. (2005). "Precise, Contactless Handling of Nanoliter-to-Microliter Liquid Volumes." *Journal of the Association for Laboratory Automation*. [[Link](#)]

Need Custom Synthesis?

BenchChem offers custom synthesis for rare earth carbides and specific isotopic labeling.

Email: info@benchchem.com or [Request Quote Online](#).

Sources

- 1. pubs.acs.org [pubs.acs.org]
- To cite this document: BenchChem. [Application Note: High-Throughput Screening of Dispiro[3.1.3.1]decane Libraries]. BenchChem, [2026]. [Online PDF]. Available at: [<https://www.benchchem.com/product/b1434347/docs#application-note-high-throughput-screening-of-dispiro-3-1-3-1-decane-libraries>]

Disclaimer & Data Validity:

The information provided in this document is for Research Use Only (RUO) and is strictly not intended for diagnostic or therapeutic procedures. While BenchChem strives to provide accurate protocols, we make no warranties, express or implied, regarding the fitness of this product for every specific experimental setup.

Technical Support: The protocols provided are for reference purposes. Unsure if this reagent suits your experiment?

Need Industrial/Bulk Grade? [Request Custom Synthesis Quote](#)

BenchChem

Our mission is to be the trusted global source of essential and advanced chemicals, empowering scientists and researchers to drive progress in science and industry.

Contact

Address: 3281 E Guasti Rd

Ontario, CA 91761, United States

Phone: (601) 213-4426

Email: info@benchchem.com

[Contact our Ph.D. Support Team for a compatibility check](#)