

# Technical Support Center: Optimizing Acquisition for $^{13}\text{C}$ -Labeled Nucleosides

**Author:** BenchChem Technical Support Team. **Date:** May 2026

## Compound of Interest

Compound Name: *2'-Deoxycytidine-2'- $^{13}\text{C}$   
Monohydrate*

CAS No.: *478511-23-8*

Cat. No.: *B1433882*

[Get Quote](#)

## Introduction: The Economics of Signal

As researchers, we understand that a  $^{13}\text{C}$ -labeled nucleoside sample often represents a significant investment of synthetic effort or budget. Unlike proton NMR, where signal is abundant,  $^{13}\text{C}$  acquisition is a war against noise, relaxation times, and sample heating.

This guide is not a generic manual. It is a decision-making framework designed to help you extract the maximum amount of data from your labeled samples without cooking them or wasting instrument time. We focus on the three critical axes of  $^{13}\text{C}$  NMR: Sensitivity, Quantification, and Sample Integrity.

## Module 1: Maximizing Sensitivity (Signal-to-Noise)

The Scenario: You have a limited amount of labeled material. You need to see the peaks, and you don't care about integrating them perfectly.

## Core Mechanism: The Nuclear Overhauser Effect (NOE)

In standard  $^{13}\text{C}$  acquisition, we decouple protons to simplify the spectrum.<sup>[1][2]</sup> However, how we apply this decoupling during the relaxation delay defines your sensitivity. By saturating the protons during the delay, we transfer magnetization to the carbons (NOE), theoretically increasing signal by up to 200% (NOE factor ).

## Troubleshooting Q&A

Q: I am running a standard zgpg30 (Power-Gated) sequence. Why are my quaternary base carbons (C2, C4, C6) so much weaker than the ribose carbons?

A: This is a relaxation and NOE issue, not just concentration.

- NOE Dependence: The NOE enhancement depends on the proximity of protons. Ribose carbons (directly attached to H) get full enhancement. Quaternary base carbons rely on long-range interactions and receive minimal NOE enhancement.
- T1 Relaxation: Quaternary carbons have very long longitudinal relaxation times ( ), often 5–15 seconds. If your repetition rate ( ) is too fast, these nuclei become saturated.

Protocol: Optimization for Sensitivity

- Pulse Angle: Use a pulse (Flip angle) rather than . This allows for faster repetition rates without saturating slow-relaxing quaternary carbons.
- Decoupling: Use WALTZ-16 or GARP during acquisition, but ensure the decoupler is ON during the relaxation delay ( ) to build up NOE.
- Repetition Time: Set

to

of the protonated carbons (usually 1–2s for sugars). Do not wait for the quaternaries if you only need detection; signal averaging (more scans) is more efficient than waiting for full relaxation in this specific mode.

## Module 2: Sample Integrity & Heating (The "Cooked Sample" Problem)

**The Scenario:** Your nucleoside is dissolved in a high-salt buffer (common for RNA/DNA mimics). After a 12-hour overnight run, the baseline is distorted, or the sample has degraded.

### Core Mechanism: Dielectric Heating

<sup>13</sup>C acquisition requires continuous proton decoupling. In high-salt samples, the sample acts as a conductive loop. The electric field component of the decoupling pulse generates heat (dielectric loss), potentially raising sample temperature by 10–20°C, leading to peak shifting or degradation.

### Troubleshooting Q&A

**Q:** How do I prevent sample heating without losing resolution?

**A:** You must move away from "hard" decoupling pulses (like standard GARP) toward Adiabatic Decoupling.

**The Solution:** Adiabatic Decoupling (WURST/CHIRP) Adiabatic pulses use frequency sweeps to invert spins with much lower peak power than rectangular pulses.

- Standard Decoupling (GARP/WALTZ): High power, narrow bandwidth. High heating risk.
- Adiabatic Decoupling: Lower average power, very wide bandwidth. Minimal heating.[\[3\]](#)[\[4\]](#)[\[5\]](#)

**Protocol:** Implementing Low-Heat Acquisition

- Pulse Sequence: Switch to a sequence that supports adiabatic decoupling (often denoted with .ad in Bruker libraries).

- Shape: Use CHIRP or WURST shapes for the decoupling channel (f2).
- Calibration: If adiabatic sequences are unavailable, reduce the Duty Cycle. Increase (relaxation delay) and turn the decoupler OFF during (Inverse Gated, see Module 3). This gives the sample time to cool between scans.

## Module 3: Quantitative Accuracy (qNMR)

The Scenario: You need to determine the ratio of an impurity to your labeled nucleoside, or integration values are critical.

### Core Mechanism: Inverse Gated Decoupling

To integrate accurately, you must eliminate the NOE, because NOE enhancement varies for every carbon (see Module 1). You must also wait for full relaxation.

### Troubleshooting Q&A

Q: My integrals are inconsistent. The ribose signals integrate to 1.0, but the base signals are 0.6.

A: You are suffering from NOE bias and saturation.

- The Fix: Use Inverse Gated Decoupling (e.g., zgig).<sup>[6][7]</sup>
  - Decoupler ON: During Acquisition (to collapse J-couplings for singlet peaks).
  - Decoupler OFF: During Delay ( ) (to kill NOE buildup).
- The Cost: You lose the NOE signal boost (sensitivity drops by ~3x). You must scan longer.

Q: How long must I wait between scans?

A: For qNMR, the repetition delay must be

of the slowest relaxing nucleus (usually the carbonyls).

- Example: If C4 carbonyl

, your delay must be

.

- Pro-Tip: Add a Relaxation Agent.<sup>[7]</sup> Adding 20–50 mM Cr(acac)<sub>3</sub> (Chromium acetylacetonate) can reduce all

values to < 1s, allowing you to use a standard 2–3s delay and save hours of instrument time.

## Visual Decision Matrix

The following diagram illustrates the logical flow for selecting the correct acquisition parameters based on your experimental goals.

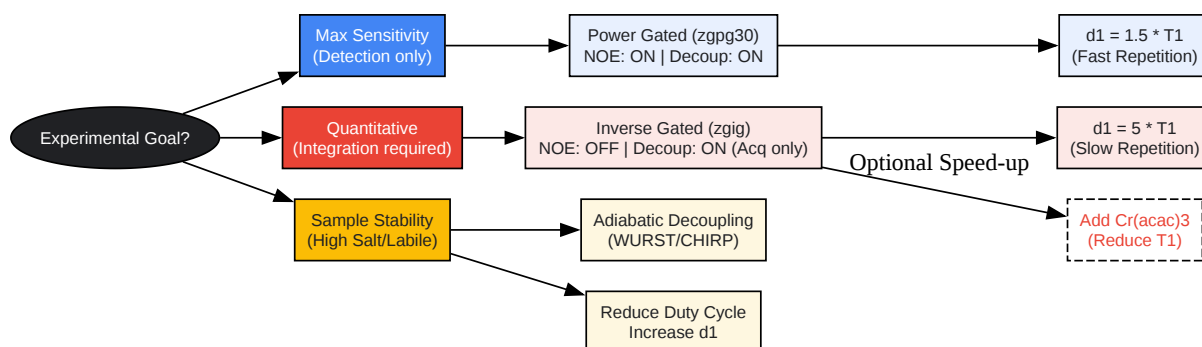

[Click to download full resolution via product page](#)

Caption: Decision tree for selecting pulse sequences and parameters based on sensitivity, quantification needs, or sample heating constraints.

## Experimental Protocols

### Protocol 1: T1 Measurement (Inversion Recovery)

Before running a 24-hour qNMR experiment, spend 30 minutes measuring T1. This prevents under-relaxation artifacts.

- Pulse Sequence:  $t1irpg$  (Inversion Recovery with Power Gated decoupling).
- List Setup: Create a variable delay list (vdlist) with 10–12 points ranging exponentially.
  - Range: 0.01s, 0.05s, 0.1s, 0.5s, 1s, 2s, 4s, 8s, 15s.
- Acquisition: Run the experiment. You will see peaks start inverted (negative), pass through a null point, and become positive.
- Calculation: The null point ( $\tau$ ) relates to  $T_1$  by:  
$$\tau = T_1 \ln(2)$$
- Application: Set your qNMR delay ( $\tau$ ) to the longest calculated  $\tau$ .

## Protocol 2: Temperature Calibration

Essential for high-salt nucleoside samples to ensure the displayed temperature matches the actual sample temperature during decoupling.

- Standard: Use a sealed capillary of Ethylene Glycol (for high temp) or Methanol (for low temp) inside your NMR tube.
- Measure: Acquire a single scan  $^1H$  spectrum.
- Calculate: The chemical shift difference ( $\Delta\delta$ ) between the  $CH_2$  and  $OH$  peaks is temperature-dependent.
  - Formula (Glycol):  
$$\Delta\delta = 0.0015(T - 25) + 0.0005$$

- Check: Run your decoupling sequence for 10 minutes, then immediately measure the standard again to see how much the decoupling heated the sample.

## Summary Data Table: Decoupling & Sequence Selection

Feature	Power Gated (zgpg30)	Inverse Gated (zgig)	Adiabatic Decoupling
Primary Use	Routine ID, Max Sensitivity	Quantitative Analysis (qNMR)	Thermolabile/High-Salt Samples
NOE Status	Maximized (Enhances signal)	Suppressed (Integrals accurate)	Variable (usually ON)
Decoupling	ON during d1 & Acq	ON during Acq ONLY	ON (Low Power Shaped Pulse)
Heating Risk	High	Low (due to low duty cycle)	Lowest
Recycle Delay			
Relative S/N	100% (Reference)	~30–40%	~90–100%

## References

- Claridge, T. D. W. (2016). High-Resolution NMR Techniques in Organic Chemistry. Elsevier. [4] (Chapter 4: Heteronuclear NMR).
- Bruker BioSpin. (2020). Adiabatic Decoupling in High Resolution NMR. Bruker Application Notes.
- Simova, S. (2008). "Adiabatic decoupling in NMR spectroscopy of nucleosides." Journal of Magnetic Resonance.
- Holzgrabe, U. (2010). "Quantitative NMR spectroscopy in pharmaceutical applications." Progress in Nuclear Magnetic Resonance Spectroscopy.

- Reich, H. J. (2023). "Relaxation in NMR." University of Wisconsin-Madison Chemistry.

### Need Custom Synthesis?

BenchChem offers custom synthesis for rare earth carbides and specific isotopic labeling.

Email: [info@benchchem.com](mailto:info@benchchem.com) or [Request Quote Online](#).

## Sources

- [1. orgchemboulder.com](https://orgchemboulder.com) [orgchemboulder.com]
- [2. Carbon-13 nuclear magnetic resonance - Wikipedia](https://en.wikipedia.org) [en.wikipedia.org]
- [3. TUTORIAL:Adiabatic Decoupling](https://imserc.northwestern.edu) [imserc.northwestern.edu]
- [4. ethz.ch](https://ethz.ch) [ethz.ch]
- [5. nmr.oxinst.jp](https://nmr.oxinst.jp) [nmr.oxinst.jp]
- [6. andreas-brinkmann.net](https://andreas-brinkmann.net) [andreas-brinkmann.net]
- [7. Development of quantitative <sup>13</sup>C NMR characterization and simulation of C, H, and O content for pyrolysis oils based on <sup>13</sup>C NMR analysis - RSC Advances \(RSC Publishing\)](#) DOI:10.1039/D0RA02376K [pubs.rsc.org]
- To cite this document: BenchChem. [Technical Support Center: Optimizing Acquisition for <sup>13</sup>C-Labeled Nucleosides]. BenchChem, [2026]. [Online PDF]. Available at: [<https://www.benchchem.com/product/b1433882/docs#technical-support-center-optimizing-acquisition-for-13c-labeled-nucleosides>]

---

### Disclaimer & Data Validity:

The information provided in this document is for Research Use Only (RUO) and is strictly not intended for diagnostic or therapeutic procedures. While BenchChem strives to provide accurate protocols, we make no warranties, express or implied, regarding the fitness of this product for every specific experimental setup.

**Technical Support:** The protocols provided are for reference purposes. Unsure if this reagent suits your experiment?

**Need Industrial/Bulk Grade?** [Request Custom Synthesis Quote](#)

# BenchChem

Our mission is to be the trusted global source of essential and advanced chemicals, empowering scientists and researchers to drive progress in science and industry.

## Contact

Address: 3281 E Guasti Rd

Ontario, CA 91761, United States

Phone: (601) 213-4426

Email: [info@benchchem.com](mailto:info@benchchem.com)

[Contact our Ph.D. Support Team for a compatibility check](#)