

Application Note: Stereoselective Synthesis of Spiro[2.5]octane Derivatives

Author: BenchChem Technical Support Team. **Date:** May 2026

Compound of Interest

Compound Name: 6,6-Difluorospiro[2.5]octane-1-carboxylic acid

CAS No.: 1447943-53-4

Cat. No.: B1433241

[Get Quote](#)

Executive Summary

The spiro[2.5]octane scaffold represents a privileged structural motif in modern drug discovery, offering a rigid, three-dimensional alternative to gem-dimethyl groups. Its high

character and defined vectors allow for precise exploration of chemical space, particularly in fragment-based drug design (FBDD). However, the construction of this strained system—specifically with control over diastereoselectivity and enantioselectivity—remains a significant bottleneck.

This guide details two field-validated protocols for the stereoselective synthesis of spiro[2.5]octane derivatives:

- Hydroxyl-Directed Simmons-Smith Cyclopropanation: For high diastereocontrol using substrate-inherent chirality.
- Rh(II)-Catalyzed Asymmetric Cyclopropanation: For high enantiocontrol using chiral catalyst architectures.^[1]

Strategic Methodology & Decision Matrix

The choice of method depends primarily on the existing functionality of the substrate and the requirement for absolute vs. relative stereocontrol.

Method Selection Guide

The following decision matrix outlines the optimal synthetic pathway based on substrate class.

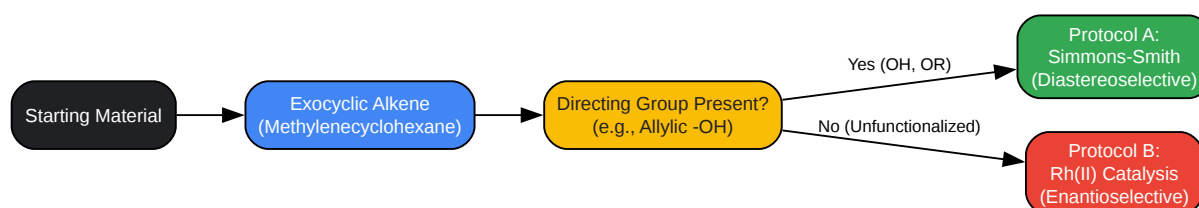

[Click to download full resolution via product page](#)

Figure 1: Decision matrix for selecting the appropriate cyclopropanation strategy based on substrate functionality.

Protocol A: Hydroxyl-Directed Simmons-Smith Cyclopropanation

Objective: Synthesis of diastereomerically pure spiro[2.5]octanes utilizing 1,2-induction from an allylic alcohol. Mechanism: The reaction proceeds via a butterfly-type transition state where the zinc carbenoid coordinates to the hydroxyl oxygen, delivering the methylene group to the syn face of the alkene.

Materials & Reagents[2][3][4][5][6][7][8][9]

- Substrate: 2-Methylene-cyclohexan-1-ol (or derivative).
- Reagent: Diethylzinc (), 1.0 M in hexanes.
- Carbenoid Source: Diiodomethane (

, >99%, stabilized with Cu).

- Solvent: Dichloromethane (DCM), anhydrous.
- Quench: Saturated aqueous

Step-by-Step Procedure

- Inert Setup: Flame-dry a 2-neck round-bottom flask equipped with a magnetic stir bar, nitrogen inlet, and a pressure-equalizing addition funnel. Cool to 0°C.
- Substrate Solubilization: Add the allylic alcohol substrate (1.0 equiv) dissolved in anhydrous DCM (0.2 M concentration).
- Reagent Formation (Furukawa Modification):
 - Add

(2.2 equiv) dropwise via syringe. Caution: Pyrophoric.
 - Stir for 15 minutes at 0°C to allow formation of the zinc alkoxide intermediate.
- Carbenoid Addition:
 - Add

(2.2 equiv) dropwise over 20 minutes.
 - Note: The solution may become cloudy or form a white precipitate ().
- Reaction: Allow the mixture to warm to room temperature (RT) and stir for 4–12 hours. Monitor conversion by TLC or LCMS.
- Quenching (Critical Safety Step):
 - Cool the mixture back to 0°C.

- Slowly add saturated
 . Warning: Vigorous gas evolution (ethane).
- Workup: Separate phases. Extract aqueous layer with DCM (
). Wash combined organics with 10%
 (to remove iodine traces) and brine. Dry over
 .

Expected Results

- Yield: 85–95%
- Diastereomeric Ratio (dr): Typically >20:1 (syn:anti).

Protocol B: Rh(II)-Catalyzed Enantioselective Cyclopropanation

Objective: Construction of chiral spiro[2.5]octanes from unfunctionalized exocyclic alkenes using Donor-Acceptor carbenoids. Catalyst:

(Tetrakis[1-(4-tert-butylphenyl)adamantane-1-carboxylate]dirhodium). This bulky catalyst creates a chiral pocket that enforces high enantioselectivity.

Materials & Reagents[2][3][4][5][6][7][8][9]

- Substrate: Methylene cyclohexane derivative.
- Carbene Precursor: Methyl phenyldiazoacetate (Donor-Acceptor diazo).
- Catalyst:
 (0.5 – 1.0 mol%).
- Solvent: 2,2-Dimethylbutane (or Hexanes/DCM 10:1 mixture).

Step-by-Step Procedure

- Catalyst Solution: In a flame-dried Schlenk tube under argon, dissolve (1.0 mol%) and the alkene substrate (1.0 equiv) in the solvent (0.1 M). Heat to reflux (approx. 50°C for 2,2-dimethylbutane).
- Diazo Addition (Rate Limiting):
 - Dissolve methyl phenyldiazoacetate (1.2 equiv) in the reaction solvent.
 - Using a syringe pump, add the diazo solution to the refluxing catalyst mixture very slowly (over 2–4 hours).
 - Reasoning: Slow addition maintains a low concentration of the diazo species, preventing homocoupling (formation of fumarates/maleates) and favoring the reaction with the alkene.
- Completion: Stir for an additional 1 hour after addition is complete.
- Purification: Concentrate the reaction mixture directly under reduced pressure. Purify via silica gel flash chromatography.

Expected Results

- Yield: 70–85%
- Enantiomeric Excess (ee): 90–98%
- Diastereoselectivity: >10:1 (trans-cyclopropane favored relative to the bulky ester group).

Comparative Analysis of Methods

Feature	Simmons-Smith (Protocol A)	Rh(II) Catalysis (Protocol B)
Stereocontrol Source	Substrate (Chiral alcohol)	Catalyst (Chiral Ligand)
Primary Selectivity	Diastereoselectivity (Syn)	Enantioselectivity
Substrate Requirement	Requires directing group (-OH)	Electronic tuning (Electron-rich alkene)
Scalability	High (kg scale feasible)	Moderate (Catalyst cost)
Safety Profile	Pyrophoric reagents ()	Hazardous reagents (Diazo compounds)

Troubleshooting & Expert Insights

Mechanistic Visualization: Directed Cyclopropanation

Understanding the transition state is crucial for predicting stereochemical outcomes in complex substrates.

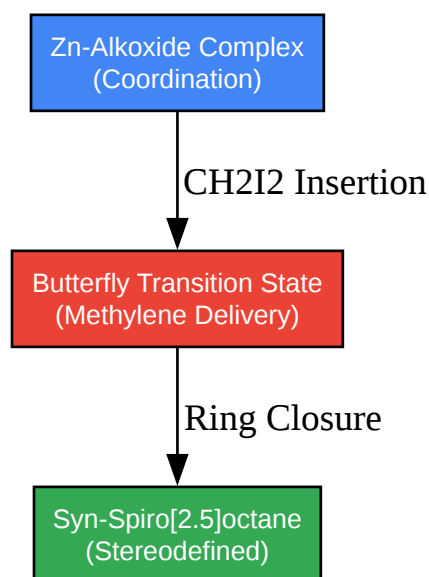

[Click to download full resolution via product page](#)

Figure 2: Mechanistic flow of the hydroxyl-directed Simmons-Smith reaction.

Common Pitfalls

- Stalled Reaction (Simmons-Smith): If the reaction is sluggish, add catalytic amounts of Trifluoroacetic acid (TFA) or use 1,2-dichloroethane (DCE) as solvent and heat to 60°C. The "Shi Modification" (using) can accelerate carbenoid formation.
- Diazo Dimerization (Rh-Catalysis): If yield is low and maleate/fumarate byproducts are observed, dilute the reaction further or slow the addition rate of the diazo compound.
- Purification: Spiro[2.5]octane derivatives lack UV chromophores unless functionalized. Use or Anisaldehyde stain for TLC visualization.

References

- Simmons-Smith Mechanism & Furukawa Modification
 - Simmons, H. E., & Smith, R. D. (1959). A New Synthesis of Cyclopropanes. *Journal of the American Chemical Society*.
- Hydroxyl-Directed Stereocontrol
 - Charette, A. B., & Marcoux, J. F. (2003). The Simmons-Smith Reaction: From Methodology to Target-Oriented Synthesis. *Synlett*.
- Rh(II)
 - Wang, H., Guptill, D. M., Varela-Alvarez, A., Musaev, D. G., & Davies, H. M. L. (2013). Rhodium-catalyzed enantioselective cyclopropanation of electron-deficient alkenes. *Chemical Science*.
- Spiro[2.
 - Wiberg, K. B. (1996). Properties of Some Spiro[2.n]alkanes. *Journal of Organic Chemistry*.

Need Custom Synthesis?

BenchChem offers custom synthesis for rare earth carbides and specific isotopic labeling.

Email: info@benchchem.com or [Request Quote Online](#).

Sources

- 1. Rhodium-catalyzed enantioselective cyclopropanation of electron deficient alkenes - PMC [[pmc.ncbi.nlm.nih.gov](https://pubmed.ncbi.nlm.nih.gov/)]
- To cite this document: BenchChem. [Application Note: Stereoselective Synthesis of Spiro[2.5]octane Derivatives]. BenchChem, [2026]. [Online PDF]. Available at: [<https://www.benchchem.com/product/b1433241/docs#application-note-stereoselective-synthesis-of-spiro-2-5-octane-derivatives>]

Disclaimer & Data Validity:

The information provided in this document is for Research Use Only (RUO) and is strictly not intended for diagnostic or therapeutic procedures. While BenchChem strives to provide accurate protocols, we make no warranties, express or implied, regarding the fitness of this product for every specific experimental setup.

Technical Support: The protocols provided are for reference purposes. Unsure if this reagent suits your experiment?

Need Industrial/Bulk Grade? [Request Custom Synthesis Quote](#)

BenchChem

Our mission is to be the trusted global source of essential and advanced chemicals, empowering scientists and researchers to drive progress in science and industry.

Contact

Address: 3281 E Guasti Rd
Ontario, CA 91761, United States
Phone: (601) 213-4426
Email: info@benchchem.com

Contact our Ph.D. Support Team for a compatibility check