

Technical Guide: Mogroside V vs. Mogroside IVa Biosynthesis

Author: BenchChem Technical Support Team. **Date:** February 2026

Compound of Interest

Compound Name: *Mogroside IVa*

CAS No.: 88901-41-1

Cat. No.: B1431267

[Get Quote](#)

Overcoming the Glycosylation Bottleneck in High-Intensity Sweetener Production

Executive Summary

Mogroside V (Mog V) is the commercially dominant triterpene glycoside in *Siraitia grosvenorii* (Monk fruit), valued for its high sweetness potency (~250-400x sucrose) and superior solubility. However, metabolic engineering efforts in heterologous hosts (e.g., *Saccharomyces cerevisiae*, *Nicotiana benthamiana*) frequently stall at **Mogroside IVa**, a tetra-glycosylated precursor.

The transition from **Mogroside IVa** to Mogroside V represents a critical kinetic bottleneck. It requires a specific, sterically challenging 1

6 branched glycosylation at the C-24 position. This guide dissects the enzymatic mechanisms governing this step, the structural divergence, and actionable protocols for pathway optimization and analysis.

Molecular Architecture: The Critical Difference

Understanding the structural isomerism is prerequisite to engineering the pathway. Both compounds share the mogrol aglycone (10

-cucurbit-5-ene-3

,11

,24R,25-tetraol) but differ in the architecture of the sugar chain at the C-24 position.[1]

Feature	Mogroside IVa (Precursor)	Mogroside V (Target)
Formula		
C-3 Moiety	Gentiobioside (Glc 1 6 Glc)	Gentiobioside (Glc 1 6 Glc)
C-24 Moiety	Sophoroside (Glc 1 2 Glc)	Branched Trisaccharide(Glc 1 2 [Glc 1 6] Glc)
Sweetness	Low / Bitter aftertaste	High / Pure sweet
Missing Link	Lacks the 1 6 branched glucose at C-24.	Fully substituted.

The Engineering Challenge: The enzyme responsible for adding the final glucose to convert IVa to V must accommodate a bulky tetra-glycosylated substrate and catalyze the formation of a branch point, which is energetically and sterically less favorable than linear elongation.

The Biosynthetic Pathway

The pathway begins with the cyclization of 2,3-oxidosqualene to cucurbitadienol, followed by P450-mediated oxidation to mogrol. The complexity arises in the cytosolic UDP-glycosyltransferase (UGT) cascade.

Pathway Visualization

The following diagram illustrates the primary flux toward Mogroside V, highlighting the "Stall Point" where **Mogroside IVa** accumulates.

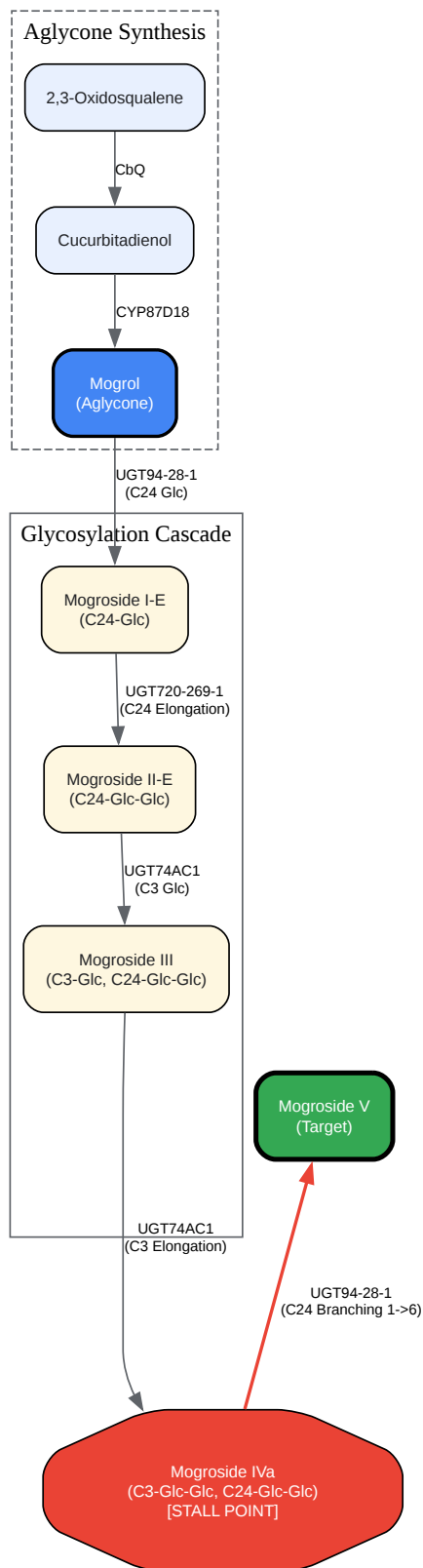

[Click to download full resolution via product page](#)

Caption: Flux diagram showing the sequential glycosylation of Mogrol. The conversion of IVa to V (red arrow) is the rate-limiting branching step.

The Enzymatic Core: UGT94-28-1

The conversion of **Mogroside IVa** to V relies heavily on UGT94-28-1 (also referenced as UGT94-289-3 in some variants). This enzyme is unique because it possesses dual capability: it initiates glycosylation at C-24 and, crucially, catalyzes the formation of the

1

6 branch.

Mechanism of Action

- **Substrate Specificity:** UGT94-28-1 recognizes the C-24 sophoroside moiety of **Mogroside IVa**.
- **Reaction:** It transfers a glucose from UDP-glucose to the C-6 hydroxyl group of the inner glucose at the C-24 position.
- **Kinetic Issues:** In vitro assays demonstrate that UGT94-28-1 has a significantly higher (lower affinity) for **Mogroside IVa** compared to Mogrol. This "substrate inhibition" or low affinity for the bulky intermediate causes the accumulation of IVa.

Engineering Solutions

To push the pathway from IVa to V, recent studies (e.g., Li et al., 2020/2022) recommend:

- **Directed Evolution:** Mutating the binding pocket of UGT94-28-1 to accommodate the larger **Mogroside IVa** substrate.
- **Enzyme Cascading:** Co-expressing UGT74AC1 (efficient C-3 glycosylator) with a high-titer variant of UGT94-28-1.
- **Siamenoside I Route:** Alternatively, routing flux through Siamenoside I (Mogrol

...

Siamenoside I

Mog V) can bypass the IVa accumulation, though this requires precise control of UGT expression ratios.

Analytical Protocol: Distinguishing IVa from V

Because IVa and V are structurally similar, standard HPLC often fails to separate them cleanly. LC-MS/MS is the gold standard for validation.

Sample Preparation

- Extraction: Extract cell pellets/plant tissue with 80% Methanol (1:10 w/v).
- Sonication: 30 mins at 40°C.
- Clarification: Centrifuge at 12,000 x g for 10 mins; filter supernatant through 0.22

m PTFE filter.

LC-MS/MS Parameters

Instrument: Triple Quadrupole MS (e.g., Agilent 6400 series or equivalent). Column: C18 Reverse Phase (e.g., Agilent ZORBAX SB-C18, 2.1 x 100 mm, 1.8

m).

Parameter	Setting
Mobile Phase A	0.1% Formic Acid in Water
Mobile Phase B	Acetonitrile
Gradient	0-2 min: 20% B; 2-15 min: 20% 50% B; 15-18 min: 90% B.
Flow Rate	0.3 mL/min
Ionization	ESI Negative Mode ()

MRM Transitions (Quantification)

Use these transitions to specifically identify the compounds based on their mass-to-charge ratio ().

Compound	Precursor Ion ()	Product Ion ()	Retention Time (Approx)
Mogroside V	1285.6	1123.6 (Loss of 1 Glc)	6.5 min
Mogroside IVa	1123.6	961.5 (Loss of 1 Glc)	7.8 min
Siamenoside I	1123.6	961.5	7.2 min

Note: **Mogroside IVa** and Siamenoside I are isomers (

1123.6). They must be separated chromatographically. IVa generally elutes later than Siamenoside I and Mog V due to the lack of the bulky branched structure making it slightly more hydrophobic.

Experimental Workflow: In Vitro Enzyme Assay

To validate the conversion of IVa to V by a candidate UGT:

- Reaction Mix (100

L):

- 50 mM Tris-HCl (pH 7.5)

- 5 mM

- 10 mM

-mercaptoethanol

- 2 mM UDP-Glucose (Donor)

- 200

M **Mogroside IVa** (Substrate - purified)

- 5

g Purified Recombinant UGT94-28-1

- Incubation: 30°C for 2-12 hours.

- Termination: Add 100

L ice-cold methanol.

- Analysis: Inject into LC-MS/MS using the protocol above.

- Success Criteria: Appearance of peak at

1285.6 (Mog V) and depletion of peak at

1123.6 (Mog IVa).

References

- Itkin, M., et al. (2016). "The biosynthetic pathway of the nonsugar, high-intensity sweetener mogroside V from *Siraitia grosvenorii*." Proceedings of the National Academy of Sciences,

113(47), E7619-E7628.

- Li, J., et al. (2020). "Glycosyltransferase engineering and multi-glycosylation routes development facilitating biosynthesis of high-intensity sweetener mogrosides." *Microbial Cell Factories*. (Contextualized via search results regarding UGT engineering).
- Zhang, H., et al. (2016). "Liquid chromatography with tandem mass spectrometry method for the simultaneous determination of multiple sweet mogrosides." *Journal of Separation Science*, 39(21), 4124-4135.
- Li, C., et al. (2022). "De novo biosynthesis of mogroside V by multiplexed engineered yeasts." *Nature Communications*.

Need Custom Synthesis?

BenchChem offers custom synthesis for rare earth carbides and specific isotopic labeling.

Email: info@benchchem.com or [Request Quote Online](#).

Sources

- [1. researchgate.net \[researchgate.net\]](https://www.researchgate.net)
- To cite this document: BenchChem. [Technical Guide: Mogroside V vs. Mogroside IVa Biosynthesis]. BenchChem, [2026]. [Online PDF]. Available at: [\[https://www.benchchem.com/product/b1431267#mogroside-iva-vs-mogroside-v-biosynthesis-pathway\]](https://www.benchchem.com/product/b1431267#mogroside-iva-vs-mogroside-v-biosynthesis-pathway)

Disclaimer & Data Validity:

The information provided in this document is for Research Use Only (RUO) and is strictly not intended for diagnostic or therapeutic procedures. While BenchChem strives to provide accurate protocols, we make no warranties, express or implied, regarding the fitness of this product for every specific experimental setup.

Technical Support: The protocols provided are for reference purposes. Unsure if this reagent suits your experiment? [[Contact our Ph.D. Support Team for a compatibility check](#)]

Need Industrial/Bulk Grade? [Request Custom Synthesis Quote](#)

BenchChem

Our mission is to be the trusted global source of essential and advanced chemicals, empowering scientists and researchers to drive progress in science and industry.

Contact

Address: 3281 E Guasti Rd

Ontario, CA 91761, United States

Phone: (601) 213-4426

Email: info@benchchem.com