

Spectroscopic Profile of 2-Chloro-5-methylisonicotinic Acid: A Technical Guide

Author: BenchChem Technical Support Team. **Date:** May 2026

Compound of Interest

Compound Name: 2-Chloro-5-methylisonicotinic acid

CAS No.: 951030-56-1

Cat. No.: B1430868

[Get Quote](#)

Abstract

This technical guide provides a comprehensive analysis of the spectroscopic characteristics of **2-Chloro-5-methylisonicotinic acid**, a key building block in pharmaceutical and agrochemical research. In the absence of publicly available experimental spectra, this document leverages predictive methodologies based on established principles of nuclear magnetic resonance (NMR) spectroscopy, infrared (IR) spectroscopy, and mass spectrometry (MS). This guide is intended for researchers, scientists, and drug development professionals, offering in-depth theoretical analysis, detailed experimental protocols for data acquisition, and a thorough interpretation of the predicted spectroscopic data. The causality behind spectral features is explained to provide field-proven insights, ensuring a robust understanding of the molecule's structural properties.

Introduction: The Significance of 2-Chloro-5-methylisonicotinic Acid

2-Chloro-5-methylisonicotinic acid, with the molecular formula $C_7H_6ClNO_2$, is a substituted pyridine derivative. The unique arrangement of a chloro group, a methyl group, and a

carboxylic acid on the isonicotinic acid scaffold makes it a versatile intermediate in the synthesis of a wide range of biologically active molecules. The precise characterization of its chemical structure is paramount for ensuring the purity, identity, and quality of downstream products in drug discovery and development pipelines. Spectroscopic techniques are the cornerstone of this characterization, providing a detailed fingerprint of the molecule's atomic and molecular composition. This guide will explore the predicted ^1H NMR, ^{13}C NMR, FT-IR, and Mass Spectrometry data to build a complete structural portrait of this important compound.

Nuclear Magnetic Resonance (NMR) Spectroscopy: Elucidating the Core Scaffold

NMR spectroscopy is arguably the most powerful tool for the structural elucidation of organic molecules in solution. By probing the magnetic properties of atomic nuclei, NMR provides detailed information about the chemical environment, connectivity, and spatial arrangement of atoms within a molecule.

Predicted ^1H NMR Spectrum

The predicted ^1H NMR spectrum of **2-Chloro-5-methylisonicotinic acid** is expected to exhibit distinct signals corresponding to the aromatic protons and the methyl group protons. The chemical shifts are influenced by the electronic effects of the substituents on the pyridine ring.

Table 1: Predicted ^1H NMR Data for **2-Chloro-5-methylisonicotinic Acid**

Proton Assignment	Predicted Chemical Shift (δ , ppm)	Multiplicity	Coupling Constant (J, Hz)	Integration
H-3	~8.1	Singlet	-	1H
H-6	~8.5	Singlet	-	1H
-CH ₃	~2.4	Singlet	-	3H
-COOH	~13.0	Broad Singlet	-	1H

Causality of Predicted Chemical Shifts:

- **Aromatic Protons (H-3 and H-6):** The protons on the pyridine ring are in a deshielded environment due to the ring current effect. The electron-withdrawing nature of the nitrogen atom and the chlorine atom further deshields these protons, leading to chemical shifts in the downfield region (~8.1-8.5 ppm). The lack of adjacent protons results in singlet multiplicities for both H-3 and H-6.
- **Methyl Protons (-CH₃):** The methyl group protons are attached to the aromatic ring and will appear as a singlet at approximately 2.4 ppm.
- **Carboxylic Acid Proton (-COOH):** The proton of the carboxylic acid group is highly deshielded due to the electronegativity of the adjacent oxygen atoms and potential hydrogen bonding. It is expected to appear as a broad singlet at a very downfield chemical shift, typically around 13.0 ppm, and its position can be highly dependent on the solvent and concentration.

Predicted ¹³C NMR Spectrum

The ¹³C NMR spectrum will provide information on all the carbon atoms in the molecule, including the quaternary carbons.

Table 2: Predicted ¹³C NMR Data for **2-Chloro-5-methylisonicotinic Acid**

Carbon Assignment	Predicted Chemical Shift (δ, ppm)
C-2	~152
C-3	~125
C-4	~145
C-5	~138
C-6	~150
-CH ₃	~18
-COOH	~168

Causality of Predicted Chemical Shifts:

- **Aromatic Carbons:** The carbon atoms of the pyridine ring resonate in the aromatic region (120-160 ppm). The carbon attached to the chlorine (C-2) and the nitrogen-adjacent carbons (C-2 and C-6) are expected to be the most deshielded. The chemical shifts are influenced by the substituent effects.
- **Methyl Carbon (-CH₃):** The methyl carbon will appear in the aliphatic region, at approximately 18 ppm.
- **Carboxylic Acid Carbon (-COOH):** The carbonyl carbon of the carboxylic acid is significantly deshielded and is predicted to be around 168 ppm.

Experimental Protocol for NMR Data Acquisition

A self-validating NMR protocol ensures reproducibility and accuracy.

Diagram 1: Experimental Workflow for NMR Spectroscopy



[Click to download full resolution via product page](#)

Caption: Workflow for acquiring NMR spectra.

Step-by-Step Methodology:

- **Sample Preparation:**
 - Accurately weigh 10-20 mg of **2-Chloro-5-methylisonicotinic acid**.
 - Dissolve the sample in approximately 0.7 mL of a suitable deuterated solvent, such as DMSO-d₆, in a clean, dry vial. DMSO-d₆ is a good choice due to its ability to dissolve carboxylic acids and its high boiling point.

- Transfer the solution to a clean, 5 mm NMR tube.
- Instrument Setup:
 - Insert the NMR tube into the spectrometer's probe.
 - Lock the field frequency using the deuterium signal from the solvent.
 - Tune and match the probe to the correct frequencies for ^1H and ^{13}C .
 - Shim the magnetic field to achieve high homogeneity, resulting in sharp spectral lines.
- Data Acquisition:
 - Acquire a one-dimensional ^1H NMR spectrum using a standard pulse sequence.
 - Acquire a one-dimensional ^{13}C NMR spectrum, typically with proton decoupling to simplify the spectrum to singlets for each carbon.
- Data Processing:
 - Apply a Fourier transform to the acquired free induction decays (FIDs) to obtain the frequency-domain spectra.
 - Phase correct the spectra to ensure all peaks are in the positive absorptive mode.
 - Apply a baseline correction to obtain a flat baseline.
 - Reference the chemical shifts to an internal standard, such as tetramethylsilane (TMS) at 0.00 ppm.

Fourier-Transform Infrared (FT-IR) Spectroscopy: Identifying Functional Groups

FT-IR spectroscopy is a rapid and non-destructive technique that identifies the functional groups present in a molecule by measuring the absorption of infrared radiation, which excites molecular vibrations.

Predicted FT-IR Spectrum

The FT-IR spectrum of **2-Chloro-5-methylisonicotinic acid** will be characterized by absorptions corresponding to the O-H and C=O stretches of the carboxylic acid, C-H stretches of the methyl and aromatic groups, C=C and C=N stretches of the pyridine ring, and the C-Cl stretch.

Table 3: Predicted FT-IR Absorption Bands for **2-Chloro-5-methylisonicotinic Acid**

Vibrational Mode	Predicted Wavenumber (cm ⁻¹)	Intensity
O-H stretch (carboxylic acid dimer)	2500-3300	Broad, Strong
C-H stretch (aromatic)	3000-3100	Medium
C-H stretch (methyl)	2850-2960	Medium
C=O stretch (carboxylic acid)	1700-1725	Strong
C=C and C=N stretch (aromatic ring)	1550-1600	Medium-Strong
C-Cl stretch	700-800	Medium

Causality of Predicted Absorption Bands:

- O-H Stretch: The carboxylic acid will likely exist as a hydrogen-bonded dimer in the solid state, giving rise to a very broad and strong absorption band in the 2500-3300 cm⁻¹ region.
- C-H Stretches: Aromatic C-H stretches appear above 3000 cm⁻¹, while the methyl C-H stretches will be just below 3000 cm⁻¹.
- C=O Stretch: The carbonyl group of the carboxylic acid will produce a strong, sharp absorption band around 1700-1725 cm⁻¹.
- Aromatic Ring Stretches: The C=C and C=N stretching vibrations of the pyridine ring will result in one or more bands in the 1550-1600 cm⁻¹ region.

- C-Cl Stretch: The carbon-chlorine bond will have a characteristic absorption in the fingerprint region, between 700 and 800 cm^{-1} .

Experimental Protocol for FT-IR Data Acquisition

Diagram 2: Experimental Workflow for FT-IR Spectroscopy

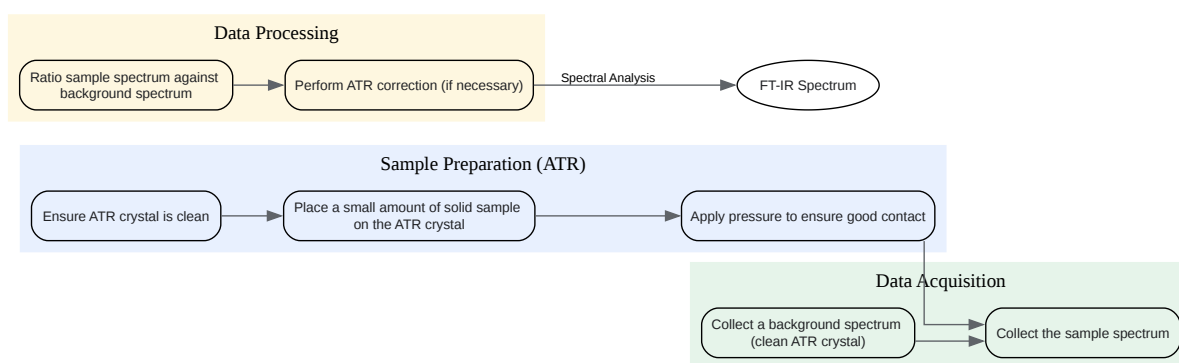

[Click to download full resolution via product page](#)

Caption: Workflow for acquiring FT-IR spectra using ATR.

Step-by-Step Methodology (using Attenuated Total Reflectance - ATR):

- Instrument Preparation:
 - Ensure the ATR crystal (e.g., diamond or germanium) is clean by wiping it with a suitable solvent (e.g., isopropanol) and allowing it to dry completely.
- Background Collection:

- Collect a background spectrum of the clean, empty ATR crystal. This will be subtracted from the sample spectrum to remove contributions from the atmosphere (e.g., CO₂ and water vapor).
- Sample Analysis:
 - Place a small amount of the solid **2-Chloro-5-methylisonicotinic acid** sample directly onto the ATR crystal.
 - Use the instrument's pressure arm to apply consistent pressure to the sample, ensuring good contact with the crystal surface.
 - Collect the sample spectrum. Typically, multiple scans (e.g., 16 or 32) are co-added to improve the signal-to-noise ratio.
- Data Processing:
 - The instrument software will automatically ratio the sample spectrum against the background spectrum to generate the final absorbance or transmittance spectrum.
 - If necessary, an ATR correction can be applied to the data to account for the wavelength-dependent depth of penetration of the evanescent wave.

Mass Spectrometry (MS): Determining Molecular Weight and Fragmentation

Mass spectrometry is a powerful analytical technique for determining the molecular weight of a compound and gaining structural information through the analysis of its fragmentation patterns.

Predicted Mass Spectrum

For **2-Chloro-5-methylisonicotinic acid** (C₇H₆ClNO₂), the expected nominal molecular weight is 171 g/mol. Due to the presence of chlorine, the mass spectrum will exhibit a characteristic isotopic pattern for the molecular ion.

Expected Observations:

- Molecular Ion (M⁺): A molecular ion peak will be observed at m/z 171.

- Isotopic Pattern: Due to the natural abundance of chlorine isotopes ($^{35}\text{Cl} \approx 75.8\%$, $^{37}\text{Cl} \approx 24.2\%$), an $(M+2)^+$ peak at m/z 173 will be observed with an intensity of approximately one-third of the M^+ peak.
- Key Fragmentation Pathways:
 - Loss of $-\text{OH}$ (M-17): A fragment at m/z 154 corresponding to the loss of a hydroxyl radical from the carboxylic acid.
 - Loss of $-\text{COOH}$ (M-45): A fragment at m/z 126 resulting from the cleavage of the carboxylic acid group.
 - Decarboxylation (M-44): A fragment at m/z 127 corresponding to the loss of CO_2 .

Diagram 3: Predicted Fragmentation of **2-Chloro-5-methylisonicotinic acid**

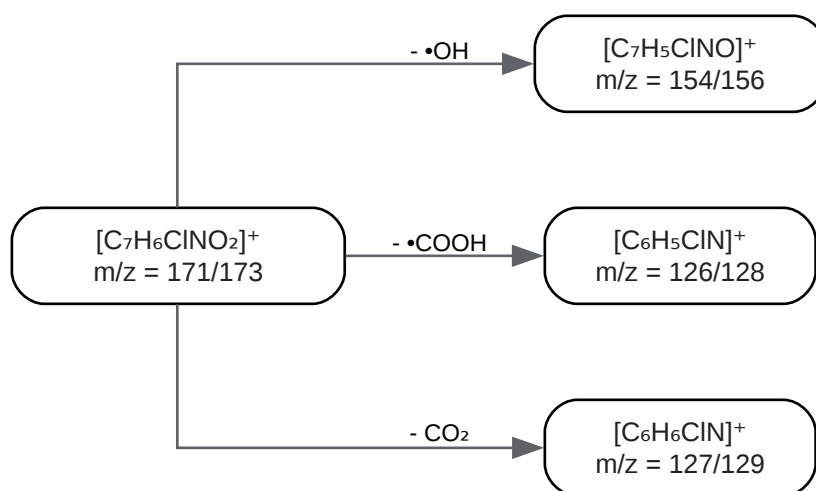

[Click to download full resolution via product page](#)

Caption: Predicted major fragmentation pathways in mass spectrometry.

Experimental Protocol for Mass Spectrometry Data Acquisition

Step-by-Step Methodology (using Electrospray Ionization - ESI):

- Sample Preparation:

- Prepare a dilute solution of **2-Chloro-5-methylisonicotinic acid** (e.g., 1-10 µg/mL) in a suitable solvent such as methanol or acetonitrile/water.
- Instrument Setup:
 - Set up the mass spectrometer with an ESI source.
 - Optimize the source parameters, including capillary voltage, nebulizer gas pressure, and drying gas flow and temperature, to achieve a stable spray and efficient ionization.
- Data Acquisition:
 - Infuse the sample solution into the mass spectrometer at a constant flow rate (e.g., 5-10 µL/min).
 - Acquire the mass spectrum in either positive or negative ion mode. For a carboxylic acid, negative ion mode ($[M-H]^-$) is often very effective.
 - To obtain fragmentation data, perform tandem mass spectrometry (MS/MS) by selecting the molecular ion (or $[M-H]^-$) and subjecting it to collision-induced dissociation (CID).

Conclusion

This technical guide has provided a detailed, predicted spectroscopic profile of **2-Chloro-5-methylisonicotinic acid**. By integrating predictive data for ^1H NMR, ^{13}C NMR, FT-IR, and mass spectrometry with established theoretical principles and detailed experimental protocols, a comprehensive understanding of the molecule's structural features has been established. The causality-driven interpretations of the predicted spectra offer valuable insights for researchers working with this compound, ensuring a solid foundation for its identification and characterization in various scientific applications. The provided protocols serve as a robust starting point for obtaining high-quality experimental data.

References

- Silverstein, R. M., Webster, F. X., Kiemle, D. J., & Bryce, D. L. (2014). Spectrometric Identification of Organic Compounds. John Wiley & Sons. [[Link](#)]

- Pavia, D. L., Lampman, G. M., Kriz, G. S., & Vyvyan, J. R. (2014). Introduction to Spectroscopy. Cengage Learning. [\[Link\]](#)
- Pretsch, E., Bühlmann, P., & Affolter, C. (2009). Structure Determination of Organic Compounds: Tables of Spectral Data. Springer Science & Business Media. [\[Link\]](#)
- de Hoffmann, E., & Stroobant, V. (2007). Mass Spectrometry: Principles and Applications. John Wiley & Sons. [\[Link\]](#)
- Fulmer, G. R., Miller, A. J. M., Sherden, N. H., Gottlieb, H. E., Nudelman, A., Stoltz, B. M., ... & Goldberg, K. I. (2010). NMR chemical shifts of trace impurities: common laboratory solvents, organics, and gases in deuterated solvents relevant to the organometallic chemist. *Organometallics*, 29(9), 2176-2179. [\[Link\]](#)
- [To cite this document: BenchChem. \[Spectroscopic Profile of 2-Chloro-5-methylisonicotinic Acid: A Technical Guide\]. BenchChem, \[2026\]. \[Online PDF\]. Available at: \[https://www.benchchem.com/product/b1430868/docs#spectroscopic-profile-of-2-chloro-5-methylisonicotinic-acid-a-technical-guide\]](#)

Disclaimer & Data Validity:

The information provided in this document is for Research Use Only (RUO) and is strictly not intended for diagnostic or therapeutic procedures. While BenchChem strives to provide accurate protocols, we make no warranties, express or implied, regarding the fitness of this product for every specific experimental setup.

Technical Support: The protocols provided are for reference purposes. Unsure if this reagent suits your experiment?

Need Industrial/Bulk Grade? [Request Custom Synthesis Quote](#)

BenchChem

Our mission is to be the trusted global source of essential and advanced chemicals, empowering scientists and researchers to drive progress in science and industry.

Contact

Address: 3281 E Guasti Rd

Ontario, CA 91761, United States

Phone: (601) 213-4426

Email: info@benchchem.com

[Contact our Ph.D. Support Team for a compatibility check](#)