

# Functionalization of the aromatic ring of 3-Chloro-2,4-dimethoxybenzoic acid

**Author:** BenchChem Technical Support Team. **Date:** May 2026

## Compound of Interest

Compound Name:	3-Chloro-2,4-dimethoxybenzoic acid
CAS No.:	914933-75-8
Cat. No.:	B1430458

[Get Quote](#)

Application Note: Strategic Functionalization of **3-Chloro-2,4-dimethoxybenzoic Acid**

## Introduction: Decoding the Electronic Manifold

**3-Chloro-2,4-dimethoxybenzoic acid** (CDBA) represents a highly specialized scaffold in medicinal chemistry, often serving as a precursor for resorcinol-based inhibitors and polyketide analogs. Successful functionalization requires a deep understanding of its "push-pull" electronic landscape.

The molecule features a unique conflict of directing effects:

- **Activation:** The methoxy groups at C-2 and C-4 are strong electron-donating groups (EDGs). They powerfully activate the ring towards Electrophilic Aromatic Substitution (EAS).
- **Steric & Electronic Locking:** The C-3 position is blocked by Chlorine. This chlorine atom is not merely a blocking group; it is a functional handle for transition metal catalysis.

- The "Sweet Spot" (C-5): The C-5 position is the thermodynamic and kinetic well for EAS. It is para to the C-2 methoxy and ortho to the C-4 methoxy, creating a synergistic activation node.
- The "Hard Spot" (C-6): Sterically hindered by the carboxylic acid and less electronically activated than C-5. Accessing this position requires Directed Ortho Metalation (DOM).

## Regioselectivity Map & Strategy

The following diagram illustrates the divergent reaction pathways available for this scaffold.

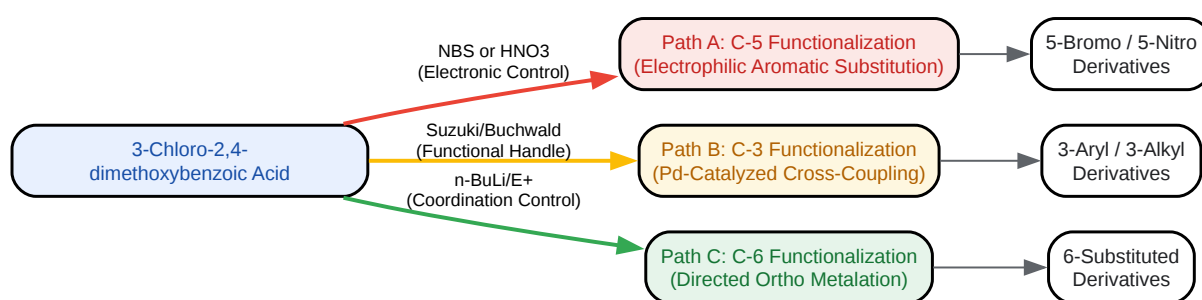

[Click to download full resolution via product page](#)

Figure 1: Strategic reaction map indicating the three primary vectors for diversifying the CDBA core.

## Path A: Electrophilic Aromatic Substitution (Targeting C-5)

The C-5 position is highly nucleophilic. Standard conditions often lead to over-reaction or decomposition. The key is mild reagents.

### Protocol 1: Regioselective C-5 Bromination

Why this works: N-Bromosuccinimide (NBS) provides a controlled source of electrophilic bromine (

), avoiding the harsh acidity and oxidizing power of elemental bromine (

).[1]

Materials:

- Substrate: 1.0 eq (e.g., 5 mmol)
- Reagent: NBS (1.05 eq)
- Solvent: Acetonitrile (MeCN) or DMF (0.2 M)
- Temperature: 0°C to Room Temperature (RT)

Step-by-Step:

- Dissolution: Dissolve **3-Chloro-2,4-dimethoxybenzoic acid** in MeCN. Ensure complete solubility; mild heating (30°C) is acceptable if needed.
- Addition: Cool the solution to 0°C. Add NBS portion-wise over 15 minutes. Critical: Rapid addition can cause exotherms that lead to decarboxylation side-products.
- Monitoring: Stir at 0°C for 30 minutes, then warm to RT. Monitor via HPLC or TLC (Mobile Phase: 50% EtOAc/Hexane). The product is usually less polar than the starting material.
- Workup: Quench with 10% aqueous sodium thiosulfate ( ) to remove trace bromine. Acidify to pH 2 with 1N HCl to ensure the product remains protonated (carboxylic acid form).
- Isolation: Extract with Ethyl Acetate (3x). Wash organics with brine, dry over , and concentrate.
- Purification: Recrystallization from Ethanol/Water is preferred over chromatography for this polar acid.

## Path B: Transition Metal Catalysis (Targeting C-3)

The C-3 chloride is a "deactivated" handle for oxidative addition because the electron-rich ring increases the electron density at the metal center, making the initial insertion step (

) thermodynamically less favorable compared to electron-deficient aryl chlorides. Furthermore, it is sterically crowded by the ortho-methoxy and carboxylic acid groups.

Solution: Use Buchwald-type dialkylbiaryl phosphine ligands (e.g., XPhos or SPhos) which facilitate oxidative addition into electron-rich chlorides and support the reductive elimination step.

## Protocol 2: Suzuki-Miyaura Cross-Coupling

Materials:

- Substrate: 1.0 eq
- Boronic Acid:  
(1.5 eq)
- Catalyst: XPhos Pd G2 (2-5 mol%)
- Base:  
(3.0 eq)
- Solvent: 1,4-Dioxane : Water (4:1 ratio)

Workflow Diagram (DOT):

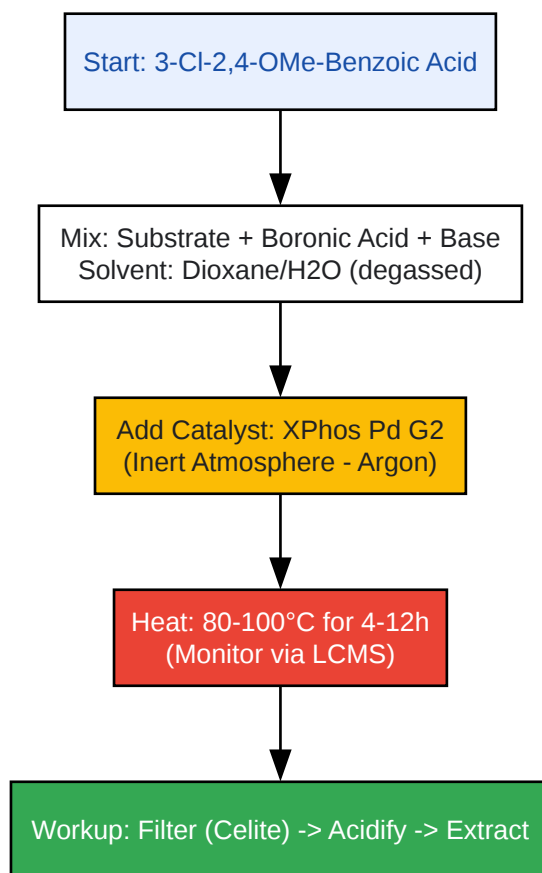

[Click to download full resolution via product page](#)

Figure 2: Optimized Suzuki-Miyaura workflow utilizing Generation 2 Buchwald Precatalysts.

#### Step-by-Step:

- Degassing: In a reaction vial, combine the substrate, boronic acid, and potassium phosphate. Crucial: Degas the solvent (Dioxane/Water) with Argon bubbling for 15 minutes before adding to the solids. Oxygen poisons the active Pd(0) species.
- Catalyst Addition: Add XPhos Pd G2 (or SPhos Pd G2). Seal the vial immediately.
- Reaction: Heat to 80°C. The reaction typically completes within 4–6 hours.
  - Note: If the carboxylic acid interferes with the coupling (via decarboxylation or catalyst binding), convert it to the methyl ester first, couple, and then hydrolyze.

- Workup: Filter through a pad of Celite to remove Palladium black. Acidify the filtrate to pH 3. Extract with EtOAc.[2]

## Path C: Directed Ortho Metalation (Targeting C-6)

Functionalizing C-6 is difficult via EAS. However, the carboxylic acid (after deprotonation to the carboxylate) can direct a strong base (Lithium) to the ortho position (C-6).

Protocol Strategy:

- Reagent:
  - Butyllithium ( $n$ -BuLi) or  $t$ -BuLi.
- Stoichiometry: Requires 2.2 equivalents of base.
  - Eq 1: Deprotonates the -COOH to (The Directing Group).
  - Eq 2: Deprotonates the C-6 proton.
- Electrophiles: Methyl iodide (MeI), DMF (for aldehyde), or (for di-acid).

Caution: This reaction must be performed at  $-78^{\circ}\text{C}$  under strict anhydrous conditions. The 3-Cl group poses a risk of "benzyne" formation if the temperature rises, as the lithium can eliminate LiCl.

## Summary of Conditions

Target Position	Reaction Type	Key Reagents	Critical Parameter
C-5	EAS (Bromination)	NBS, MeCN	Temperature control (0°C) to prevent over-bromination.
C-5	EAS (Nitration)	,	Use Acetyl Nitrate (generated in situ) for milder conditions than .
C-3	Cross-Coupling	, Pd-Cat	Requires electron-rich ligands (XPhos/SPhos) due to deactivated Cl.
C-6	Lithiation (DOM)	-BuLi (2.2 eq)	Cryogenic (-78°C) required to prevent benzyne formation via Cl elimination.

## References

- Electrophilic Aromatic Substitution Selectivity
  - Smith, M. B. "March's Advanced Organic Chemistry: Reactions, Mechanisms, and Structure." 8th Ed. Wiley. (General reactivity of 2,4-dimethoxybenzenes).
  - Wikipedia. "Electrophilic aromatic substitution."<sup>[1][3][4][5][6][7]</sup> Available at: [\[Link\]](#)<sup>[6]</sup>
- Suzuki Coupling of Chlorides
  - Common Organic Chemistry. "Suzuki Reaction - Palladium Catalyzed Cross Coupling." Available at: [\[Link\]](#)
  - Organic Chemistry Portal. "Suzuki Coupling."<sup>[8][9][10]</sup> Available at: [\[Link\]](#)
- Specific Scaffold Reactivity (Nitration/Synthesis)

- PrepChem. "Preparation of 3-Nitro-4-chloro-5-chlorosulfonylbenzoic acid." [11]  
(Demonstrates nitration patterns on similar chlorinated benzoic acids). Available at: [\[Link\]](#)

### Need Custom Synthesis?

BenchChem offers custom synthesis for rare earth carbides and specific isotopic labeling.

Email: [info@benchchem.com](mailto:info@benchchem.com) or [Request Quote Online](#).

## Sources

- 1. [web.mnstate.edu](http://web.mnstate.edu) [[web.mnstate.edu](http://web.mnstate.edu)]
- 2. [Suzuki Reaction - Palladium Catalyzed Cross Coupling](http://commonorganicchemistry.com) [[commonorganicchemistry.com](http://commonorganicchemistry.com)]
- 3. [Electrophilic aromatic substitution - Wikipedia](http://en.wikipedia.org) [[en.wikipedia.org](http://en.wikipedia.org)]
- 4. [chem.libretexts.org](http://chem.libretexts.org) [[chem.libretexts.org](http://chem.libretexts.org)]
- 5. [masterorganicchemistry.com](http://masterorganicchemistry.com) [[masterorganicchemistry.com](http://masterorganicchemistry.com)]
- 6. [lecturio.com](http://lecturio.com) [[lecturio.com](http://lecturio.com)]
- 7. [quora.com](http://quora.com) [[quora.com](http://quora.com)]
- 8. [Suzuki Coupling](http://organic-chemistry.org) [[organic-chemistry.org](http://organic-chemistry.org)]
- 9. [Suzuki-Miyaura Cross-Coupling Reaction](http://fishersci.se) [[fishersci.se](http://fishersci.se)]
- 10. [chem.libretexts.org](http://chem.libretexts.org) [[chem.libretexts.org](http://chem.libretexts.org)]
- 11. [prepchem.com](http://prepchem.com) [[prepchem.com](http://prepchem.com)]
- To cite this document: BenchChem. [Functionalization of the aromatic ring of 3-Chloro-2,4-dimethoxybenzoic acid]. BenchChem, [2026]. [Online PDF]. Available at: [\[https://www.benchchem.com/product/b1430458/docs#functionalization-of-the-aromatic-ring-of-3-chloro-2-4-dimethoxybenzoic-acid\]](https://www.benchchem.com/product/b1430458/docs#functionalization-of-the-aromatic-ring-of-3-chloro-2-4-dimethoxybenzoic-acid)

### Disclaimer & Data Validity:

The information provided in this document is for Research Use Only (RUO) and is strictly not intended for diagnostic or therapeutic procedures. While BenchChem strives to provide accurate protocols, we make no warranties, express or implied, regarding the fitness of this product for every specific experimental setup.

**Technical Support:** The protocols provided are for reference purposes. Unsure if this reagent suits your experiment?

**Need Industrial/Bulk Grade?** [Request Custom Synthesis Quote](#)

## BenchChem

Our mission is to be the trusted global source of essential and advanced chemicals, empowering scientists and researchers to drive progress in science and industry.

### Contact

Address: 3281 E Guasti Rd  
Ontario, CA 91761, United States  
Phone: (601) 213-4426  
Email: [info@benchchem.com](mailto:info@benchchem.com)

[Contact our Ph.D. Support Team for a compatibility check](#)